

CITY COUNCIL
CITY OF NORTHAMPTON
MASSACHUSETTS

Councilors:

- President Gina-Louise Sciarra, At-Large
- William H. Dwight, At-Large
- Michael J. Quinlan, Jr., Ward 1
- Karen Foster, Ward 2
- Vice-President James Nash, Ward 3
- John Thorpe, Ward 4
- Alex Jarrett, Ward 5
- Marianne L. LaBarge, Ward 6
- Rachel Maiore, Ward 7

Meeting Agenda
On-line Video Conference
Meeting Date: May 6, 2021
Meeting Time: 7 p.m.

The May 6, 2021 City Council meeting will be held by remote participation. The public can follow the council's deliberations by watching the meeting live on Comcast channel 15, live-streaming it on YouTube or joining the virtual meeting by phone or computer. For the active YouTube link, please see Northampton Open Media's website: <http://northamptonopenmedia.org/>

Live public comment will be available using telephone call-in or video conferencing technology beginning at 7 p.m.

INSTRUCTIONS FOR CALLING IN OR JOINING THE MEETING

Join meeting: <https://bit.ly/3sUdjUe>

For telephone call-in, call:

+253 215-8785 US

+301 715-8592 US

MEETING ID: 934 2443 0260

PARTICIPANT #: #

PASSCODE: 585930

1. Announcement that Meeting is Being Held Via Remote Participation and Audio/Video Recorded

This meeting is being held via remote participation and audio/video recorded.

2. Public Comment

3. Roll Call

4. Public Hearings

A. 7:05 pm **Public Hearing on 21.197 National Grid/Verizon Petition for Installation of Underground Conduit on Damon Road (Petition#23303524)**

Per M.G.L. Ch. 166, Section 22, the Northampton City Council will hold a public hearing on **Thursday, May 6, 2021 at 7:05 p.m.** on National Grid/Verizon New England's petition to install underground conduit on Damon Road (Petition #23303524). The City Council will hear all persons who wish to be heard thereon.

Documents:

[21.197 DPW Recommendation.pdf](#)

[21.197 Distribution Civil Drawings - REVISED.pdf](#)

B. **Announcement of Public Hearing on 21.238 National Grid/Verizon Pole Petition for One (1) Jointly-owned (JO) Pole on Damon Road (Petition#23303524)**

Per M.G.L. Ch. 166, Section 22, the Northampton City Council will hold a public hearing on **Thursday, May 20, 2021 at 7:30 p.m.** on National Grid/Verizon New England's petition to install one jointly-owned (JO) pole on Damon Road (Petition #23303524). Instructions for accessing the hearing may be found on the May 20, 2021 City Council agenda to be posted on the city website (www.northamptonma.gov) at least 48 hours prior to the meeting. The City Council will hear all persons who wish to be heard thereon.

Documents:

[21.238 DPW Recommendation.pdf](#)

[21.238 National Grid-Verizon Pole Petition for Damon Road.pdf](#)

C. **Announcement of Public Hearing on 21.239 National Grid/Verizon Pole Petition for Two (2) Jointly-owned (JO) Poles on Burts Pit Road (Petition#30025210)**

Per M.G.L. Ch. 166, Section 22, the Northampton City Council will hold a public hearing on **Thursday, May 20, 2021 at 7:15 p.m.** on National Grid/Verizon New England's petition to install two jointly-owned (JO) poles on Burts Pit Road (Petition #30025210). Instructions for accessing the hearing may be found on the May 20, 2021 City Council agenda to be posted on the city website (www.northamptonma.gov) at least 48 hours prior to the meeting. The City Council will hear all persons who wish to be heard thereon.

Documents:

[21.239 BPR Plan.pdf](#)

[21.239 DPW Recommendation.pdf](#)

D. Announcement of Public Hearing for 21.261 Application for License to Store Flammables and Combustibles at 140 Olander Drive

Per M.G.L. Chapter 148, Section 13, North Commons at Village Hill, LLC has submitted an application for a License to Store Flammables and Combustibles for one (1) 4,000-gallon LP Gas underground storage tank at 140 Olander Drive, Northampton, MA.

The City Council will hold a public hearing by video conference on **Thursday, May 20, 2021 at 7:05 p.m.** Instructions for accessing the hearing may be found on the May 20, 2021 City Council agenda to be posted on the city website (www.northamptonma.gov) at least 48 hours prior to the meeting.

The City Council will hear all persons who wish to be heard thereon. The City Council meeting begins **at 7 p.m.**

5. Updates from Council President and Committee Chairs

6. Recognitions and One-Minute Announcements by Councilors

7. Communications and Proclamations from the Mayor

A. Municipal Broadband Update

8. Resolutions

A. 21.266 A Resolution in Support of Workers of the Hampshire Gazette - 1st reading

Documents:

[21.266 A Resolution in Support of Workers of the Hampshire Gazette.pdf](#)

B. 21.267 A Resolution in Support of the Recommendations of the Northampton Policing Review Commission - 1st reading

Documents:

[21.267 A Resolution in Support of the Recommendations of the Northampton Policing Review Commission.pdf](#)

9. Presentations

10. Consent Agenda

A. Minutes of April 1, 2021

B. Approve 21.197 National Grid/Verizon Petition for Installation of Underground Conduit on Damon Road (Petition#23303524)

See documents under public hearing above.

C. 21.260 Petition for Second Hand Dealer License - Cancer Connection

Renewal License for:

Cancer Connection, 375 South Street

Applicant: Christine Quinn

Documents:

[21.260 Second Hand Dealer License for Cancer Connection.pdf](#)

D. 21.262 Application for Business Owner's Permit - Jeffrey D. Miller, Cosmic Cab Co.

Renewal License for:

Jeffrey D. Miller, Cosmic Cab Co.

Business Address: 160 Main Street, #8

E. 21.263 Applications for Seven (7) Taxicab Licenses, Jeffrey Miller - Cosmic Cab Company

Renewal Licenses for Taxi Cabs for the following vehicles:

- 2001 Chevy Suburban
- 2005 Chevy Magnum
- 2007 Chevy Suburban
- 2008 Dodge Caravan
- 2008 Black Dodge Caravan
- 2008 PT Cruiser

F. 21.268 Reappointments to Various Committees - for referral to City Services Committee

Agricultural Commission

John J. Bobala, 25 Old Ferry Road, Northampton

Term: July 2021-June 2024

Reappointment

Richard E. Jaescke, 774 Bridge Road, Northampton

Term: July 2021-June 2024

Reappointment

Robert Vollinger, 460 North Farms Road, Florence

Term: July 2021-June 2023

Reappointment

Earle “Chip” Parsons, 137 Mill Valley Road, Hadley

Term: July 2021-June 2023

Reappointment

Central Business Architecture Committee

Joseph Blumenthal, 39 Chapel St., Northampton

Term: July 2021-June 2024

Reappointment

Urban Forestry Commission

Susan Lofthouse, 15 Stoddard Street, Northampton

Term: July 2021-June 2024

Reappointment

Council on Aging

Robert Dionne, 87 Vernon Street, Northampton

Term: July 2021-June 2024

Reappointment

Jeanne Hoose, 36 South Park Terrace, Northampton

Term: July 2021-June 2024

Reappointment

Historical Commission

Dylan Gafney, 23 Marshall Street, Northampton

Term: July 2019-June 2022

Reappointment

Barbara Blumenthal, 39 Chapel Street, Northampton

Term: July 2021-June 2024

Reappointment

Housing Partnership

Julio Alves, 35 Fort Hill Terrace, Northampton

Term: July 2021 - June 2024

Reappointment

James Reis, 108 Coles Meadow Road, Northampton

Term: July 2021-June 2024

Reappointment

Parks and Recreation Commission

Julia Chevan, 8 Cosmian Avenue, Florence

Term: July 2020-June 2023

Reappointment

Planning Board

George Kohout, Full Member, 234 State Street, Northampton

Term: July 2021-June 2024

Reappointment

Zoning Board of Appeals

Maureen Scanlon, 197 Nonotuck Street, Florence

Term: July 2021-June 2024

Reappointment

Documents:

[21.268 Reappointments to Various Committees.pdf](#)

**G. 21.269 Applications for Annual Sunday and Weekday
Bowling Licenses - Northampton Bowl**

Renewal Licenses for Weekday and Sunday Bowling:

Northampton Bowl, 525 Pleasant Street
Applicant: J. Michael Corley

11. Recess for Committee on Finance (See Separate Agenda)

12. Financial Orders (on 1st reading pending Finance review)

Rule 2.6 requires the Finance Committee to consider certain financial matters.

A. 21.264 An Order for FY2021 Budget Transfers - 1st reading

Documents:

[21.264 An Order for FY2021 Budget Transfers.pdf](#)

B. 21.265 An Order Authorizing Acquisition and Establishment of a Municipal Light Plant - 1st reading

Documents:

[21.265 An Order Authorizing Acquisition and Establishment of a Municipal Light Plant.pdf](#)

13. Financial Orders (on 2nd reading)

A. 21.244 An Order to Acquire and Amend Easements at the Mill River Greenway-Smith College - 2nd reading

History:

- Positive recommendation, Finance Committee - 4/15/2021
- Passed 1st reading - 4/15/2021

Documents:

[21.244 An Order to Acquire and Amend Easements at the Mill River Greenway-Smith College.pdf](#)

B. 21.248 An Order to Appropriate CPA Funds for Historic Northampton Collections Storage - 2nd reading

History:

- Positive recommendation, Finance Committee - 4/15/2021
- Passed 1st reading - 4/15/2021

Documents:

[21.248 An Order to Appropriate CPA Funds for Historic Northampton Collections Storage.pdf](#)

C. 21.249 An Order to Appropriate \$120,000 in CPA Funds Toward Habitat Housing on Burts Pit Road - 2nd reading

History:

- Positive recommendation, Finance Committee - 4/15/2021
- Passed 1st reading - 4/15/2021

Documents:

[21.249 An Order to Appropriate 120,000 in CPA Funds Toward Habitat Housing on Burts Pit Road.pdf](#)

D. 21.250 An Order to Appropriate \$14,500 in CPA Funds to Lilly Library Stair Repair Project - 2nd reading

History:

- Positive recommendation, Finance Committee - 4/15/2021
- Passed 1st reading - 4/15/2021

Documents:

[21.250 An Order to Appropriate 14,500 in CPA Funds to Lilly Library Stair Repair Project.pdf](#)

E. 21.251 An Order to Appropriate \$70,000 in CPA Funds for Historic Preservation Plan - 2nd reading

History:

- Positive recommendation, Finance Committee - 4/15/2021
- Passed 1st reading - 4/15/2021

Documents:

[21.251 An Order to Appropriate 70,000 in CPA Funds for Historic Preservation Plan.pdf](#)

F. 21.252 An Order to Appropriate \$21,250 in CPA Funds for Damon House/Shepherd Barn Project - 2nd reading

History:

- Positive recommendation, Finance Committee - 4/15/2021
- Passed 1st reading - 4/15/2021

Documents:

[21.252 An Order to Appropriate 21,250 in CPA Funds for Damon House - Shepherd Barn Project.pdf](#)

G. 21.253 An Order to Appropriate \$60,000 in CPA Funds for Mill River Greenway Beach Project - 2nd reading

History:

- Positive recommendation, Finance Committee - 4/15/2021
- Passed 1st reading - 4/15/2021

Documents:

[21.253 An Order to Appropriate 60,000 in CPA Funds for Mill River Greenway Beach Project.pdf](#)

H. 21.254 An Order to Appropriate \$50,000 in CPA Funds to the Affordable Housing Fund - 2nd reading

History:

- Positive recommendation, Finance Committee - 4/15/2021
- Passed 1st reading - 4/15/2021

Documents:

[21.254 An Order to Appropriate 50,000 in CPA Funds to the Affordable Housing Fund.pdf](#)

I. 21.255 An Order Authorizing Acquisition of a Parcel of Land on the Southeasterly Side of Brierwood Drive - 2nd reading

History:

- Positive recommendation, Finance Committee - 4/15/2021
- Passed 1st reading - 4/15/2021

Documents:

[21.255 An Order Authorizing Acquisition of a Parcel of Land on the Southeasterly Side of Brierwood Drive.pdf](#)

[21.255 Order of Taking.pdf](#)

[21.255 Plans - Edbert Homes Inc.pdf](#)

J. 21.256 An Order Authorizing Waiver of Right of First Refusal for 2.93 Acres off Kennedy Road - 2nd reading

History:

- Positive recommendation, Finance Committee - 4/15/2021
- Passed 1st reading - 4/15/2021

Documents:

[21.256 Notice of Non-Exercise.pdf](#)

14. Orders

15. Ordinances (Not yet Referred)

Rule 5.2.3 provides that no ordinance shall be voted on by the City Council until it has been considered by the Committee on Legislative Matters.

16. Florence Traffic & Parking Ordinances Sponsored by Transportation & Parking Commission (TPC)

History:

- Scanlon Avenue and Cross Street Stop Signs (21.198 and 21.199) referred by City Council - 3/4/2021
- Pine/Maple/Mann Intersection & Pine Street Parking (21.213, 21.214, 21.215, 21.216) referred by City Council - 4/1/2021
- All positive recommendations, Legislative Matters - 4/12/2021
- Passed 1st reading - 4/15/2021

A. 21.198 An Ordinance Relative to a Stop Sign on Scanlon Avenue - 2nd reading

Documents:

[21.198 An Ordinance Relative to a Stop Sign on Scanlon Avenue.pdf](#)

B. 21.199 An Ordinance Relative to Stop Signs on Cross Street - 2nd reading

Documents:

[21.199 An Ordinance Relative to Stop Signs on Cross Street.pdf](#)

C. 21.213 An Ordinance Relative to Parking on Pine Street - 2nd reading

Documents:

[21.213 An Ordinance Relative to Parking on Pine Street.pdf](#)

D. 21.214 An Ordinance Relative to Stop Signs on Maple Street, Mann Terrace and Pine Street - 2nd reading

Documents:

[21.214 An Ordinance Relative to Stop Signs on Maple Street, Mann Terrace and Pine Street.pdf](#)

E. 21.215 An Ordinance Relative to Turning Restriction on Mann Terrace - 2nd reading

Documents:

[21.215 An Ordinance Relative to Turning Restriction on Mann Terrace.pdf](#)

F. 21.216 An Ordinance Relative to One-Way Street on Mann Terrace - 2nd reading

Documents:

[21.216 An Ordinance Relative to One-Way Street on Mann Terrace.pdf](#)

17. Ordinances

18. Information Requests (Charter Provision 2-7) and Committee Study Requests

19. New Business

20. Adjourn

Contact: G-L Sciarra, Council President
glsciarra@northamptonma.gov
(413) 570-3133



**CITY OF NORTHAMPTON, MASSACHUSETTS
DEPARTMENT OF PUBLIC WORKS
125 Locust Street
Northampton, MA 01060**

**413-587-1570
Fax 413-587-1576**

**Donna LaScaleia
Director**

Memorandum

To: Donna LaScaleia, Director of Public Works *Approved M 4-1-2021*
From: David Veleta, City Engineer
Date: March 31, 2021
Re: Council Order 21.197 – Petition for Installation and Maintenance of Underground Conduit and Manholes No. 23303524 – Damon Road Reconstruction Project MassDOT No. 608236 – Damon Road

I have reviewed Department of Public Works (DPW) records and submittals including images, sketches and reconstruction plans for MassDOT Damon Road project No. 608236. This petition with a revised plan dated March 24, 2021, includes the proposed construction of a line of underground electric conduits and manholes, including the necessary sustaining and protecting features, under and across the public ways or ways, by National Grid, referenced in City Council Order 21.197.

The installation is proposed to be located beginning at a point approximately 178 feet northeast of the centerline of the intersection of Industrial Drive and Damon Road and continuing in a northeast direction. National Grid proposes to install Manhole 1 with approximately 20 feet of four 5-inch, future use conduit to the northwest, approximately 45 feet of two 5-inch conduit to pole P7-25, approximately 377 feet of six 5-inch conduit from Manhole 1 to Manhole 2, approximately 37 feet of two 5 inch conduit from Manhole 2 to P7-50, and approximately 20 feet of four 5-inch, future use conduit to the northeast from Manhole 2, as shown on the attached plan dated March 24, 2021.

No potential conflicts were observed, but the contractor shall use caution when excavating since the exact location of the existing sewer force main is unknown.

A trench permit approved by the DPW has already been issued for the Damon Road project to Gagliarducci Construction who will be installing the manholes and conduit under contract with MassDOT. This permit will be revised to reflect the specifics of the above work upon approval of this petition by Council.

Pole & UG Petition/Permit Request Form

City

Town of _____ **WR #** _____
(circle one)

Install _____ **SO**
(quantity) **JO Poles on** _____
(circle one) (street name)

Remove _____ **SO**
(quantity) **JO Poles on** _____
(circle one) (street name)

Relocate _____ **SO**
(quantity) **JO Poles on** _____
(circle one) (street name)

Beginning at a point approximately _____ **feet** _____ **of the centerline**
(distance) (compass heading)

of the intersection of _____
(street name)

and continuing approximately _____ **feet in a** _____ **direction.**
(distance) (compass heading)

Install underground facilities:

Street(s) _____

Description of Work:

ENGINEER _____

DATE _____

DISTRIBUTION CIVIL DRAWINGS

DAMON RD

NORTHAMPTON, MA

DRAWING LIST	
DRAWING NO.	CONTENT
G-0	COVER SHEET
G-1	GENERAL NOTES
PP-1 + PP-2	PLAN & PROFILE
DET-1	MANHOLE CARDS
DET-2	MANHOLE/CONDUIT/RISER DETAILS

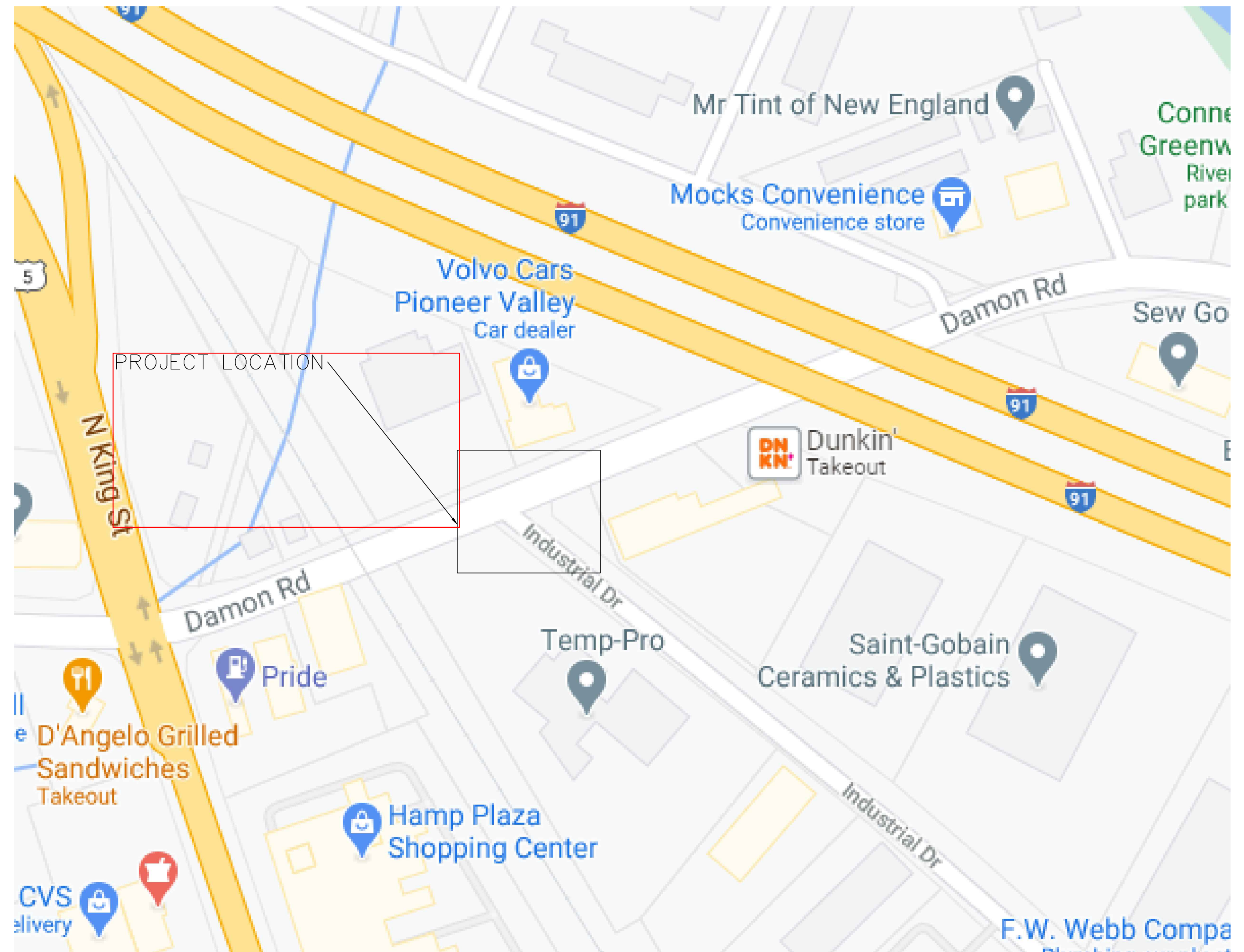

124 Grove St. Franklin, MA 02038		PROJECT NO: 270728			
REV	DESCRIPTION	DATE	DES	CHK	APP
DESIGNED					
DRAWN					
CHECKED					
APPROVED					
REVIEW 1		3/24/21			
REVIEW 2					
		DATE: 3/24/21 SCALE: NTS		MASSDOT DAMON RD LAYOUT PLAN	
		G-0		REV. 0	
WR#23303524		F.W. Webb Compa			

GENERAL NOTES:

- CONTRACTOR TO PROVIDE AS-BUILT INFORMATION 10 DAYS AFTER COMPLETION OF CONDUIT INSTALLATION WORK.
- THE LOCATIONS OF UNDERGROUND STRUCTURES SHOWN HEREIN ARE DEPICTED ACCORDING TO THE BEST AVAILABLE INFORMATION. THEY ARE NOT GUARANTEED TO BE CORRECT OR COMPLETE. IT IS THE RESPONSIBILITY OF THE CONTRACTOR TO CONFIRM ALL CONDITIONS IN THE FIELD AND MAKE ADJUSTMENTS AS REQUIRED TO ACCOMMODATE THE WORK BY GETTING APPROVAL FROM NATIONAL GRID CONSTRUCTION MANAGEMENT FIRST. IT IS ASSUMED ALL PREMISES HAVE WATER, GAS, TEL. ELEC. SEWER, ETC. LATERAL CROSSINGS WHICH SHOULD BE INCLUDED IN THE BASE BID.
- ANY QUESTIONS REGARDING THE CIVIL ENGINEERING DESIGN OF THESE CONSTRUCTION PLANS SHOULD BE REFERRED TO TRC DISTRIBUTION ENGINEER DANIEL LOPEZ AT 774-235-2603 OR DAVID TERK AT 508-298-1523.
- DO NOT DEVIATE FROM THESE PLANS WITHOUT FIRST CONTACTING NATIONAL GRID CIVIL CONSTRUCTION SUPERVISOR:
 - GARY BELLOWS 413-652-9222
- ALL UNDERGROUND CONSTRUCTION SHALL BE INSPECTED AND APPROVED BY NATIONAL GRID PERSONAL PRIOR TO CONCRETE ENCASMENT AND BACKFILL. CONTRACTOR SHALL MANDREL, PROVE, AND INSTALL MULE TAPE IN ALL CONDUITS PER NATIONAL GRID CONSTRUCTION STANDARDS UNDER SUPERVISION OF NATIONAL GRID CONSTRUCTION SUPERVISOR.
- CONTRACTOR TO ARRANGE TO HAVE ALL FOREIGN UTILITIES VERIFY THEIR LOCATIONS IN THE FIELD PRIOR TO START OF EXCAVATION WORK BY CONTACTING DIG SAFE AT "811", 1-888-DIG-SAFE. NOT ALL UTILITY SERVICES TO PROPERTIES ARE SHOWN ON THESE PLANS. REFER TO NOTE 2 ABOVE.
- PROTECT ALL MUNICIPAL, STATE, AND FEDERAL SURVEY CONTROL MONUMENTS AND BENCH MARKS. CONTRACTOR TO CONTACT RESPECTIVE MUNICIPAL ENGINEERING DEPARTMENTS FOR TYPES AND LOCATIONS BEFORE STARTING WORK AS REQUIRED.
- PROTECT ALL PLANTS AND TREES AND THEIR ROOT SYSTEMS FROM MECHANICAL AND ENVIRONMENTAL DAMAGE DURING EXCAVATION. BACKFILL ROOT AREAS WITH SOIL HAVING TEXTURE AND FERTILITY TO SUSTAIN PLANT LIFE. CONTRACTOR TO REMOVE ALL ROOTS OF DEAD TREE STUMPS FROM TRENCH PRIOR TO PLACING CONDUIT. CONTRACTOR IS RESPONSIBLE FOR THE INSTALLATION AND MAINTENANCE OF NECESSARY EROSION CONTROL (SILT SACKS, HAY BALES, CHECK DAMS, ETC.) APPROVED BY THE STATE, CITY/TOWN, AND QUONSET DEVELOPMENT CORPORATION AS REQUIRED FOR THE DURATION OF THE PROJECT.
- THE FOLLOWING MINIMUM CLEARANCES SHALL BE MAINTAINED UNLESS OTHERWISE NOTED:

UTILITY	CROSSING	PARALLEL
GAS MAIN	12"	12"
GAS SERVICE	12"	12"
WATER MAIN	12"	12"
WATER SERVICE	12"	12"
TELEPHONE/COMMUNICATION FACILITIES	12"	12"
STORM & SANITARY SEWERS	12"	12"
RAIL ROAD CROSSINGS	50"	50"

PLEASE NOTE, ANY DEVIATIONS FROM THESE MINIMUM CLEARANCES MUST BE REVIEWED AND APPROVED BY NATIONAL GRID & TRC.

UTILITY SERVICES AND LATERALS TO BUILDINGS ARE NOT SHOWN ON THESE PLANS. CONTRACTOR TO VERIFY THEIR LOCATIONS IN THE FIELD AND SUPPORT, PROTECT, MAINTAIN, AND WORK AROUND THEM AS REQUIRED IN ORDER TO COMPLETE THE PROPOSED WORK.
- ALL CONTRACTORS SHALL COMPLY WITH MINIMUM WORKING CLEARANCES FROM ALL ENERGIZED OVERHEAD EQUIPMENT AND CONDUCTORS PER OSHA REGULATIONS 1910.3333. IF MINIMUM WORKING CLEARANCES CAN NOT BE MET, CONTRACTOR MUST CONTACT NATIONAL GRID TO EVALUATE ALTERNATIVE MEASURES. THESE MEASURES MAY INCUR ADDITIONAL COSTS.
- CONDUIT TO BE PLACED AT MINIMUM 30" BELOW ELEVATION OF NEAREST PORTION OF ROAD PAVEMENT UNLESS OTHERWISE NOTED. MANHOLE ROOF TO HAVE A MINIMUM 18" OF COVER FROM FINISH GRADE UNLESS OTHERWISE NOTED.
- ALL WORK SHALL COMPLY WITH ALL APPLICABLE FEDERAL, STATE, AND MUNICIPAL CODES, AS WELL AS THE REQUIREMENTS OF THE NATIONAL ELECTRIC SAFETY CODE, OSHA REGULATIONS AND NATIONAL GRID CONSTRUCTION STANDARDS/REQUIREMENTS.
- AREAS WHERE EXCAVATION IS IN ROCK LEDGE, PROVIDE A SIX (6) INCH MINIMUM SELECT FILL CUSHION AROUND CONDUITS AND TWELVE (12) INCH CUSHION AROUND MANHOLE.

- CONTRACTOR SHALL COMPLY WITH ALL APPLICABLE FEDERAL, STATE AND LOCAL REGULATIONS REGARDING REMOVAL AND/OR DISPOSAL OF ANY AND ALL EQUIPMENT AND MATERIALS.
- CONTRACTOR SHALL MAINTAIN A FULL SIZE SET OF SCALED DRAWINGS (100% OF ALL PRINTS) ON SITE AT ALL TIMES DURING THE WORK.
- CONTRACTOR TO RECORD AND DOCUMENT A SINGLE, MULTI-PAGE .PDF PHOTOLOG OF THE ENTIRE WORK AREA. CONTRACTOR TO PROVIDE NATIONAL GRID PROJECT MANAGER A COPY OF THE PRE-CONSTRUCTION PHOTOLOG ALONG WITH A POST-CONSTRUCTION PHOTOLOG OF THE ENTIRE WORK AREA UPON COMPLETION OF ALL CIVIL WORK IN THE FIELD.
- REFER TO ALL NATIONAL GRID CIVIL CONSTRUCTION SPECIFICATIONS INCLUDED IN THE BID DOCUMENTS FOR ADDITIONAL INFORMATION REGARDING MANHOLE AND DUCT BANK INSTALLATION.

PLEASE NOTE:
THE 12" MINIMUM CLEARANCES FROM OTHER UTILITIES SHALL BE MAINTAINED WHEREVER POSSIBLE. IF THE 12" MINIMUM CLEARANCE CANNOT BE ACHIEVED IN THE FIELD, CONTRACTOR TO USE ACCEPTABLE ALTERNATIVE MEANS TO PROTECT THE OTHER UTILITIES AND/OR CONFIRM APPROVAL FROM THE UTILITY OWNER FOR LESS THAN MINIMUM CLEARANCE.

DISTRIBUTION DRAWING INDEX

REFER TO DRAWINGS:

CIVIL & PROFILE DRAWINGS	PROPOSED MANHOLE DRAWINGS	DETAIL DRAWINGS
PP-1	DET-1	DET-1 DET-2

ABBREVIATIONS

NOTE: NOT ALL ABBREVIATIONS LISTED BELOW ARE USED FOR THIS PROJECT

#	NUMBER	HV	HIGH VOLTAGE
&	AND	INV	INVERT
⊙	AT	KV	KILOVOLT
>	GREATER THAN	KVA	KILOVOLT-AMPERE
<	LESS THAN	L	LENGTH
∅	DIAMETER	LF	LINEAR FOOT
A	AMPERE	LV	LOW VOLTAGE
ABAN	ABANDONED	M	METER
ABAND	ABANDONED	MAX	MAXIMUM
AC	AIR CONDITIONER	MH	MANHOLE
AC	ALTERNATING CURRENT	MIN	MINIMUM
APPROX. APP	APPROXIMATE	MISC	MISCELLANEOUS
B/	BOTTOM OF	MJ	MECHANICAL JOINT
BIT	BITUMINOUS	MW	MONITORING WELL
BLDG	BUILDING	N	NORTH
BVCE	BEGIN VERTICAL CURVE ELEVATION	N/F	NOW OR FORMERLY
BVCS	BEGIN VERTICAL CURVE STATION	NGVD	NATIONAL GEODETIC VERTICAL DATUM
C/C	CENTER TO CENTER	NIOSH	NATIONAL INSTITUTE OF OCCUPATIONAL SAFETY AND HEALTH
CB	CATCH BASIN	PC	POINT OF CURVATURE
CI	CAST IRON	PCB	POLYCHLORINATED BIPHENYL
CL	CENTERLINE	PE	POLYETHYLENE
CLR	CLEAR	PILC	PAPER IN LEAD COVERED CABLE
CMP	CORRUGATED METAL PIPE	PIV	POST INDICATOR VALVE
CMPA	CORRUGATED METAL PIPE ARCH	PROP	PROPOSED
CMPT	COMPACT CABLE	PT	POINT, POINT OF TANGENCY
COM	COMMUNICATIONS	PVC	POLYVINYL CHLORIDE
CONC	CONCRETE	PVI	POINT OF VERTICAL INTERSECTION
CP	CONTROL POINT	R	RADIUS
CS	CARBON STEEL	RCP	REINFORCED CONCRETE PIPE
CU	COPPER	REQ'D	REQUIRED
CW	CLEAN WATER	RET	RETAINING
D	DIAMETER	RR	RAIL ROAD
DC	DIRECT CURRENT	S	SLOPE
DI	DUCTILE IRON	SCADA	SUPERVISORY CONTROL AND DATA ACQUISITION
DIA	DIAMETER	SCH	SCHEDULE
DMH	DRAIN MANHOLE	SD	STORM DRAIN
DWG	DRAWING	SF	SQUARE FEET
E	EAST	SMH	SANITARY MANHOLE
EL	ELEVATION	SQ	SQUARE
ELEC	ELECTRIC	SS	STAINLESS STEEL
ELEV	ELEVATION	STA	STATION
EMH	ELECTRIC MANHOLE	STL	STEEL
EOP	EDGE OF PAVEMENT	STORM	STORMWATER
EUE	EXISTING UNDERGROUND ELECTRIC	T&B	TOP AND BOTTOM
EUT	EXISTING UNDERGROUND TELEPHONE	T/	TOP OF
EVCE	END VERTICAL CURVE ELEVATION	TEL	TELEPHONE
EVCS	END VERTICAL CURVE STATION	TV	TELEVISION
EW	EACH WAY	TYP	TYPICAL
EX, EXIST	EXISTING	UE	UNDERGROUND ELECTRIC
FFE	FINISH FLOOR ELEVATION	UG	UNDERGROUND
FM	FORCE MAIN	UNO	UNLESS NOTED OTHERWISE
FO	FIBER OPTIC	V	VOLT
GALV	GALVANIZED	var	VOLT-AMPERE REACTIVE
GEN	GENERATOR	VC	VERTICAL CURVE
GRAN	GRANITE	VCP	VITREOUS CLAY PIPE
HDD	HORIZONTAL DIRECTIONAL DRILLING	VERT	VERTICAL
HDPE	HIGH DENSITY POLYETHYLENE	VP	VALVE PIT
HH	HANDHOLE	W	WATER
HORIZ	HORIZONTAL	W/	WITH

LEGEND

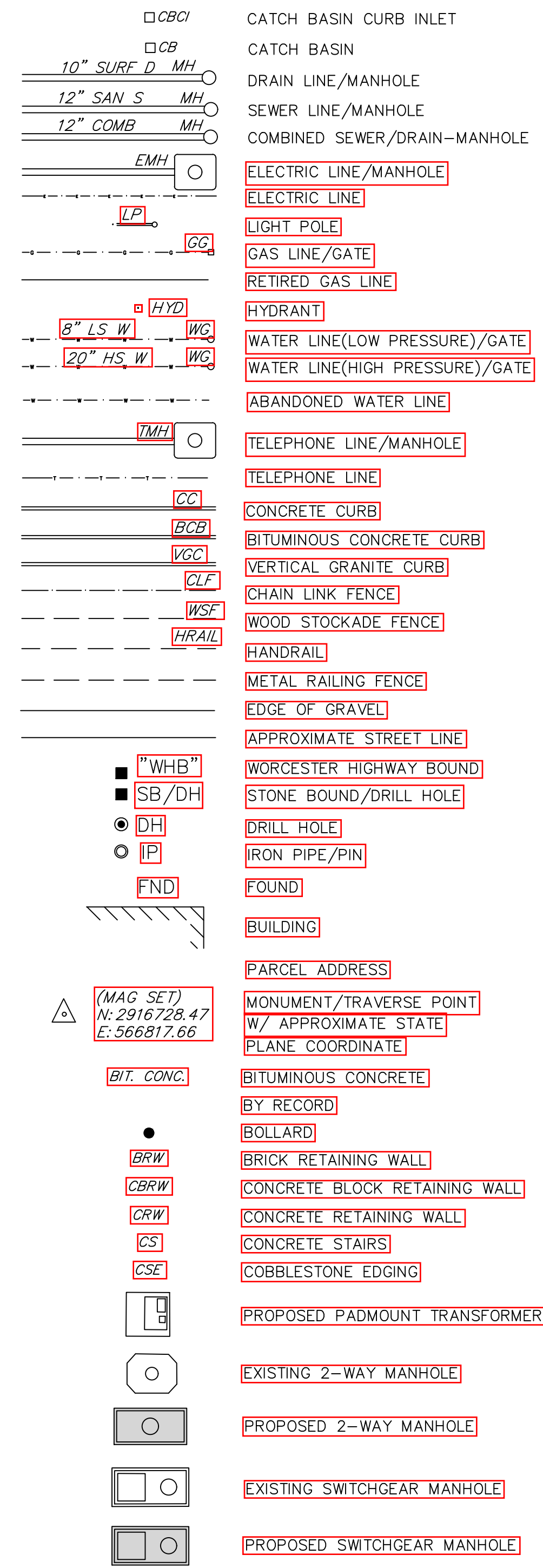

124 Grove St. Franklin, MA 02038		PROJECT No:270728		DL DESIGNED AS DRAWN			
REV DESCRIPTION DATE DES CHK APP		CHECKED APPROVED		MASSDOT DAMON RD LAYOUT PLAN		DATE 3/24/21 NTS SCALE	
REVIEW 1 REVIEW 2		REVIEW 1 REVIEW 2				G-1 WR#23303524	

PB/PG 39/15
PB/PG 181/211
32 DAMON RD

DAMON ROAD CONST. # STA. 22+56.11 =
INDUSTRIAL DR CONST. # STA. 300+00.00

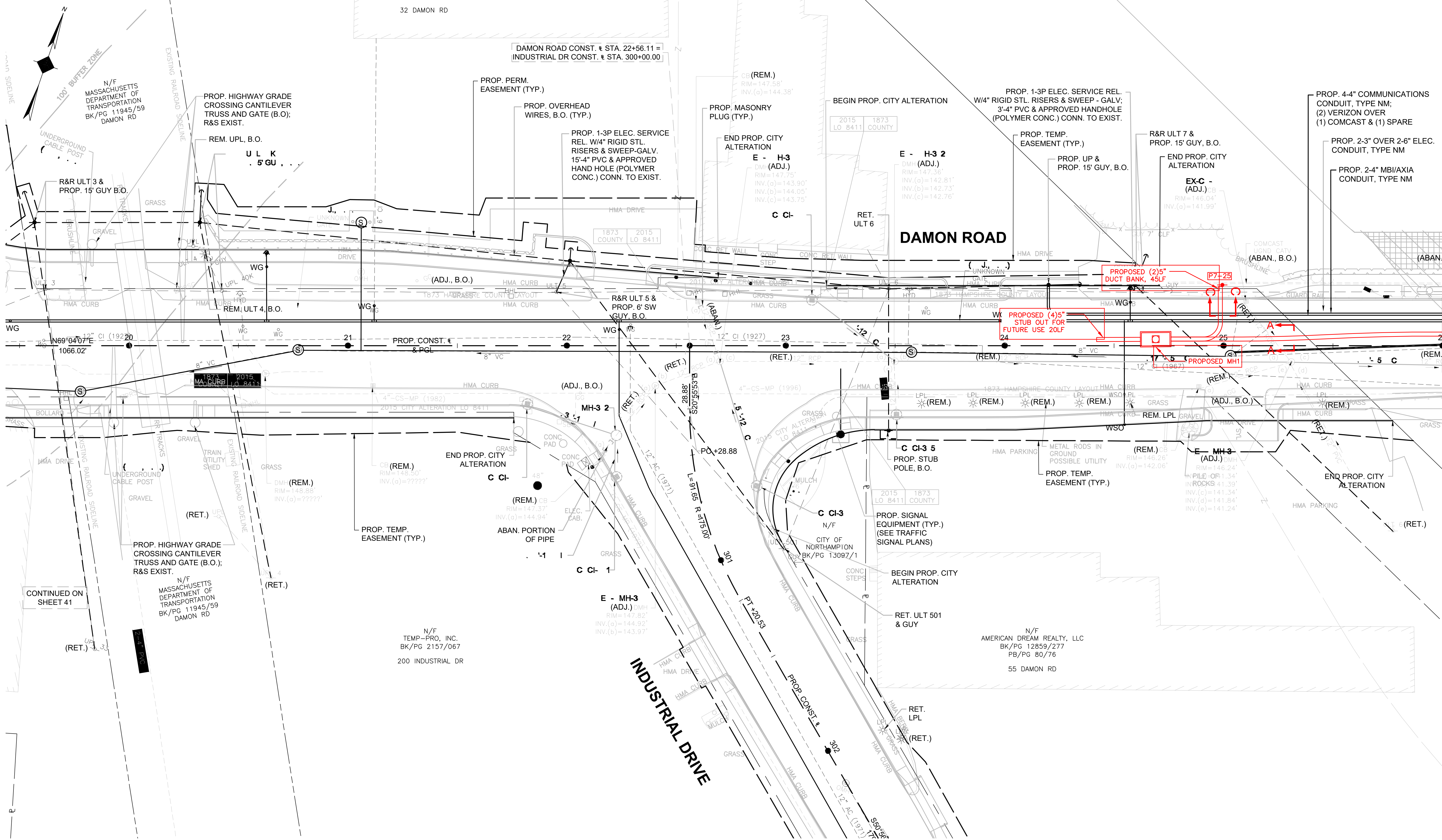

SEE PAGE PP-2

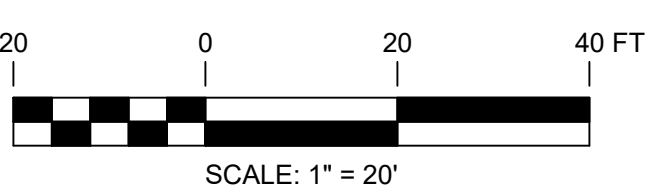

		124 Grove St. Franklin, MA 02038		PROJECT NO: 270728	
DESIGNED	AS DRAWN	CHECKED	APPROVED		
MASSDOT DAMON RD LAYOUT PLAN				PP-1	
REVIEW 1	REVIEW 2	DATE	SCALE		WR#23303524

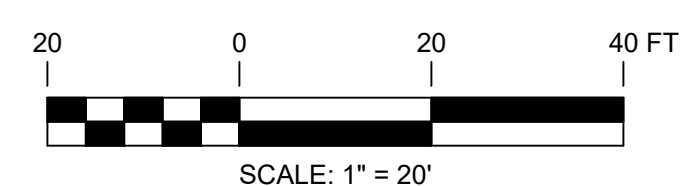
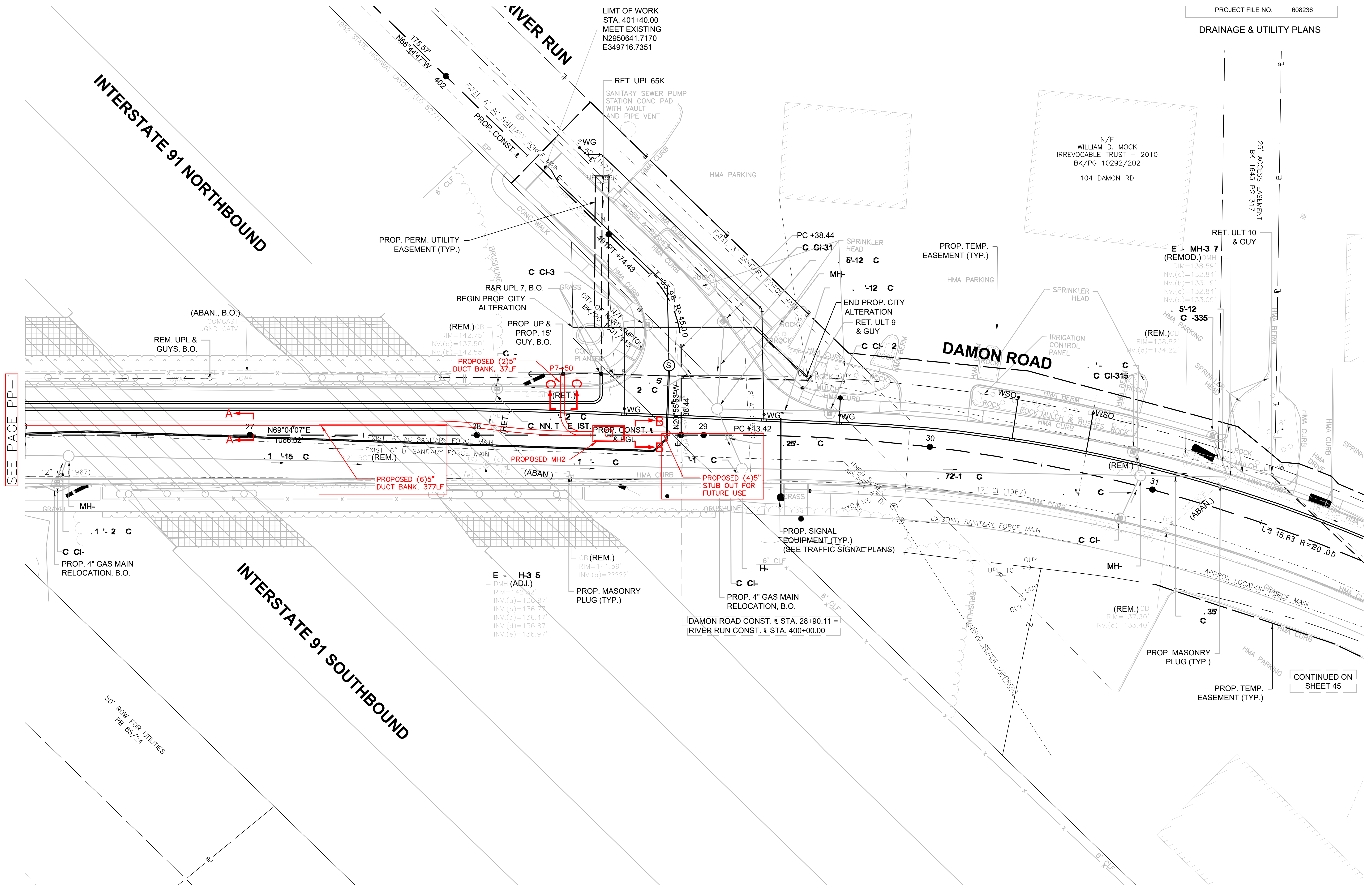
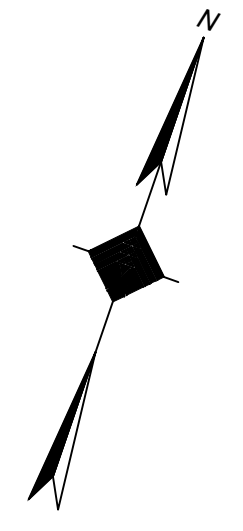

124 Grove St. Franklin, MA 02038		PROJECT NO. 270728																								
<table border="1"> <thead> <tr> <th>REV</th> <th>DESCRIPTION</th> <th>DATE</th> <th>DES</th> <th>CHK</th> <th>APP</th> </tr> </thead> <tbody> <tr> <td> </td> <td> </td> <td> </td> <td> </td> <td> </td> <td> </td> </tr> </tbody> </table>	REV	DESCRIPTION	DATE	DES	CHK	APP							<table border="1"> <tr> <td>DESIGNED</td> <td>AS</td> <td>CHECKED</td> <td>APPROVED</td> </tr> <tr> <td> </td> <td> </td> <td> </td> <td> </td> </tr> </table>				DESIGNED	AS	CHECKED	APPROVED					MASSDOT DAMON RD LAYOUT PLAN	
REV	DESCRIPTION	DATE	DES	CHK	APP																					
DESIGNED	AS	CHECKED	APPROVED																							
<table border="1"> <tr> <td>REVIEW 1</td> <td>3/24/21</td> <td>DATE</td> <td>PP-2</td> <td>REV.</td> </tr> <tr> <td>REVIEW 2</td> <td>AS NOTED</td> <td>SCALE</td> <td>WR#23303524</td> <td>0</td> </tr> </table>	REVIEW 1	3/24/21	DATE	PP-2	REV.	REVIEW 2	AS NOTED	SCALE	WR#23303524	0																
REVIEW 1	3/24/21	DATE	PP-2	REV.																						
REVIEW 2	AS NOTED	SCALE	WR#23303524	0																						

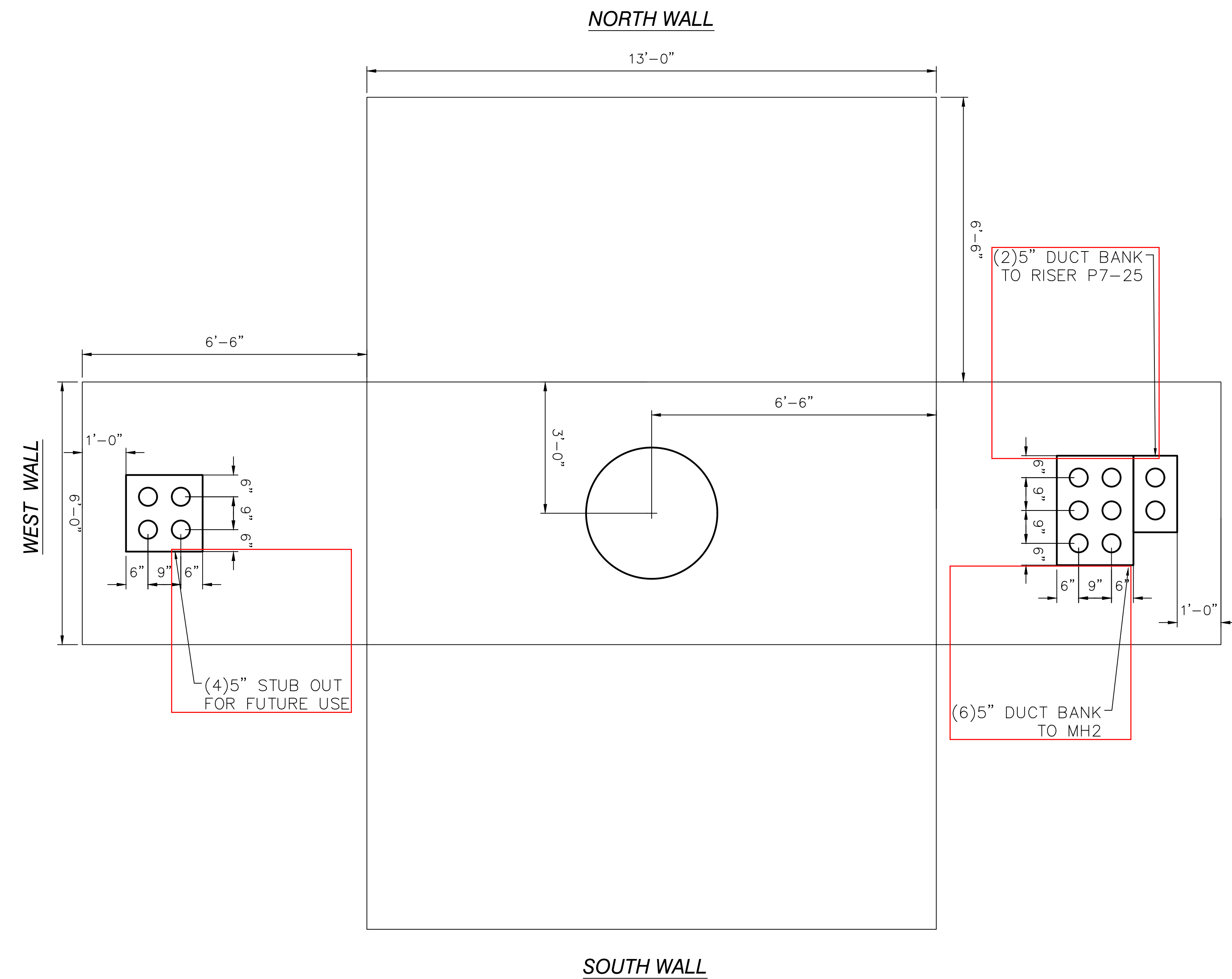

MANHOLE NUMBER: MH1

SIZE: L=13' W=6' H=6'-6"
 MANHOLE RING SIZE: 36"
 MANHOLE COVER SIZE: 26"
 CHIMNEY HEIGHT: 2'-0"

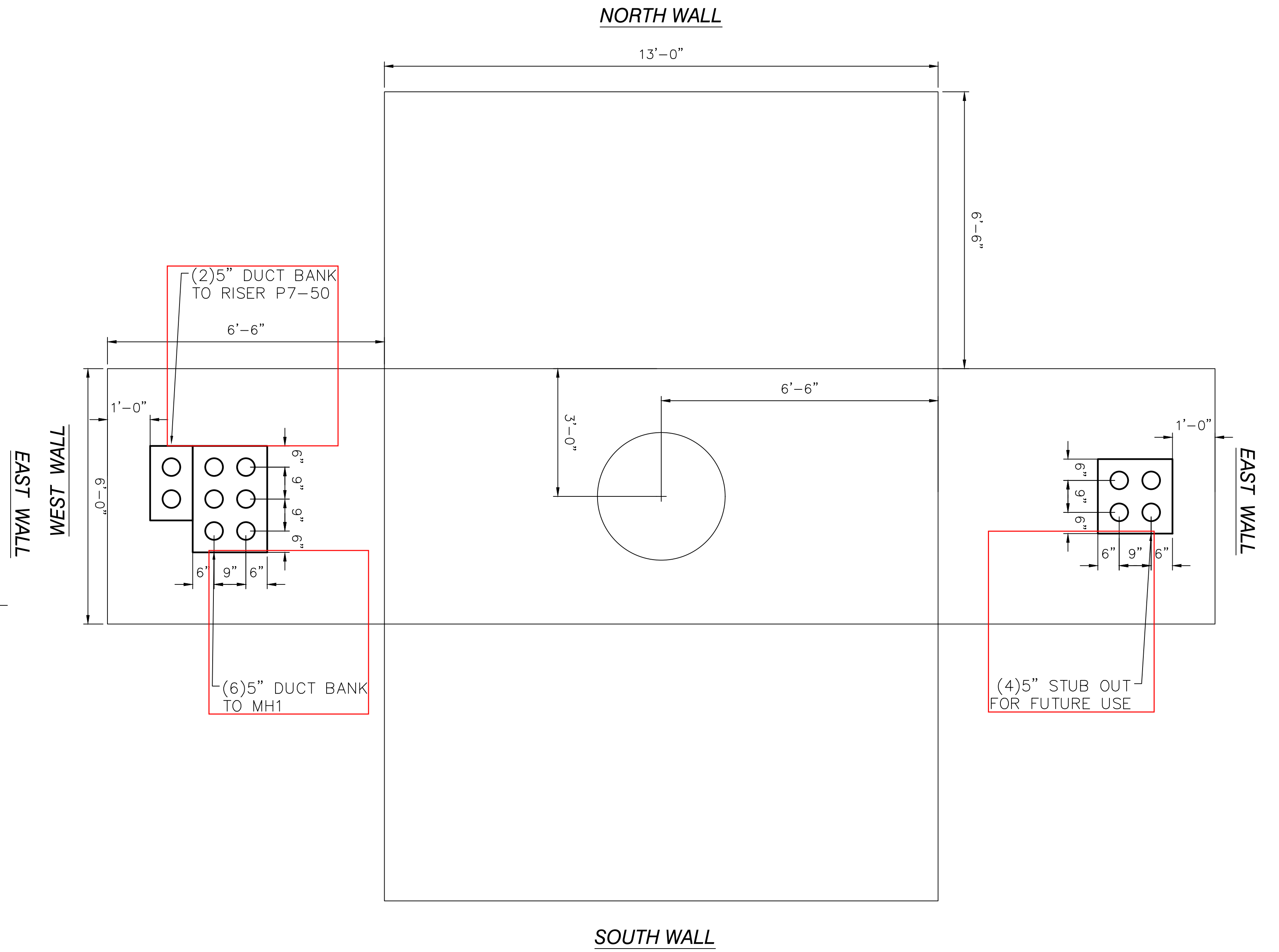

MANHOLE NUMBER: MH2

SIZE: L=13' W=6' H=6'-6"
 MANHOLE RING SIZE: 36"
 MANHOLE COVER SIZE: 26"
 CHIMNEY HEIGHT: 2'-0"

		124 Grove St. Franklin, MA 02038		PROJECT NO: 270728																																	
<table border="1"> <thead> <tr> <th>REV</th> <th>DESCRIPTION</th> <th>DATE</th> <th>DES</th> <th>CHK</th> <th>APP</th> </tr> </thead> <tbody> <tr> <td> </td> <td> </td> <td> </td> <td> </td> <td> </td> <td> </td> </tr> <tr> <td> </td> <td> </td> <td> </td> <td> </td> <td> </td> <td> </td> </tr> <tr> <td> </td> <td> </td> <td> </td> <td> </td> <td> </td> <td> </td> </tr> </tbody> </table>		REV	DESCRIPTION	DATE	DES	CHK	APP																			<table border="1"> <tr> <td>DESIGNED</td> <td> </td> </tr> <tr> <td>DRAWN</td> <td> </td> </tr> <tr> <td>CHECKED</td> <td> </td> </tr> <tr> <td>APPROVED</td> <td> </td> </tr> </table>		DESIGNED		DRAWN		CHECKED		APPROVED		MASSDOT DAMON RD LAYOUT PLAN	
REV	DESCRIPTION	DATE	DES	CHK	APP																																
DESIGNED																																					
DRAWN																																					
CHECKED																																					
APPROVED																																					
<table border="1"> <tr> <td>REVIEW 1</td> <td> </td> </tr> <tr> <td>REVIEW 2</td> <td> </td> </tr> </table>		REVIEW 1		REVIEW 2		3/24/21 DATE NTSI SCALE				DET-1 WR#23303524																											
REVIEW 1																																					
REVIEW 2																																					

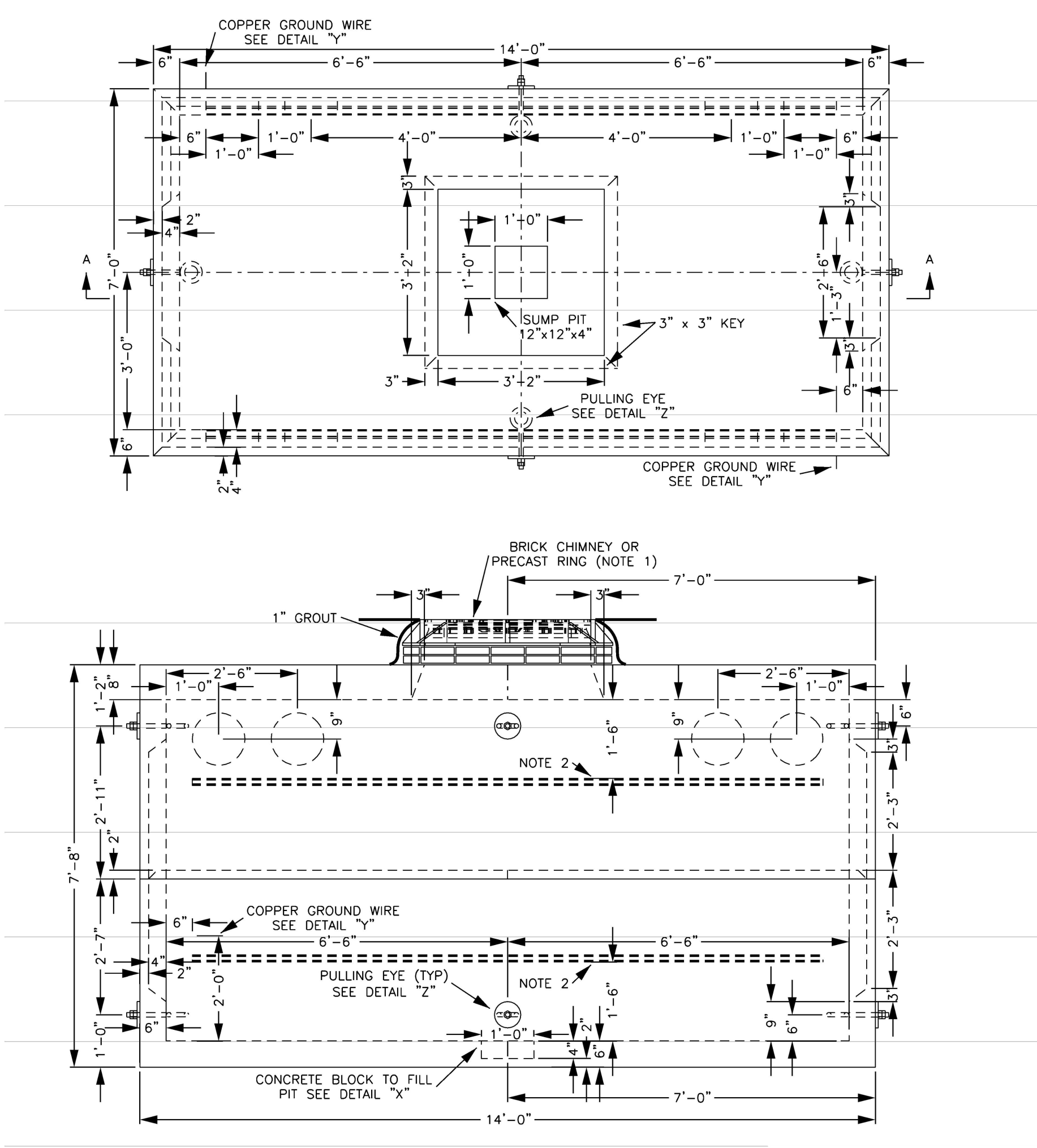
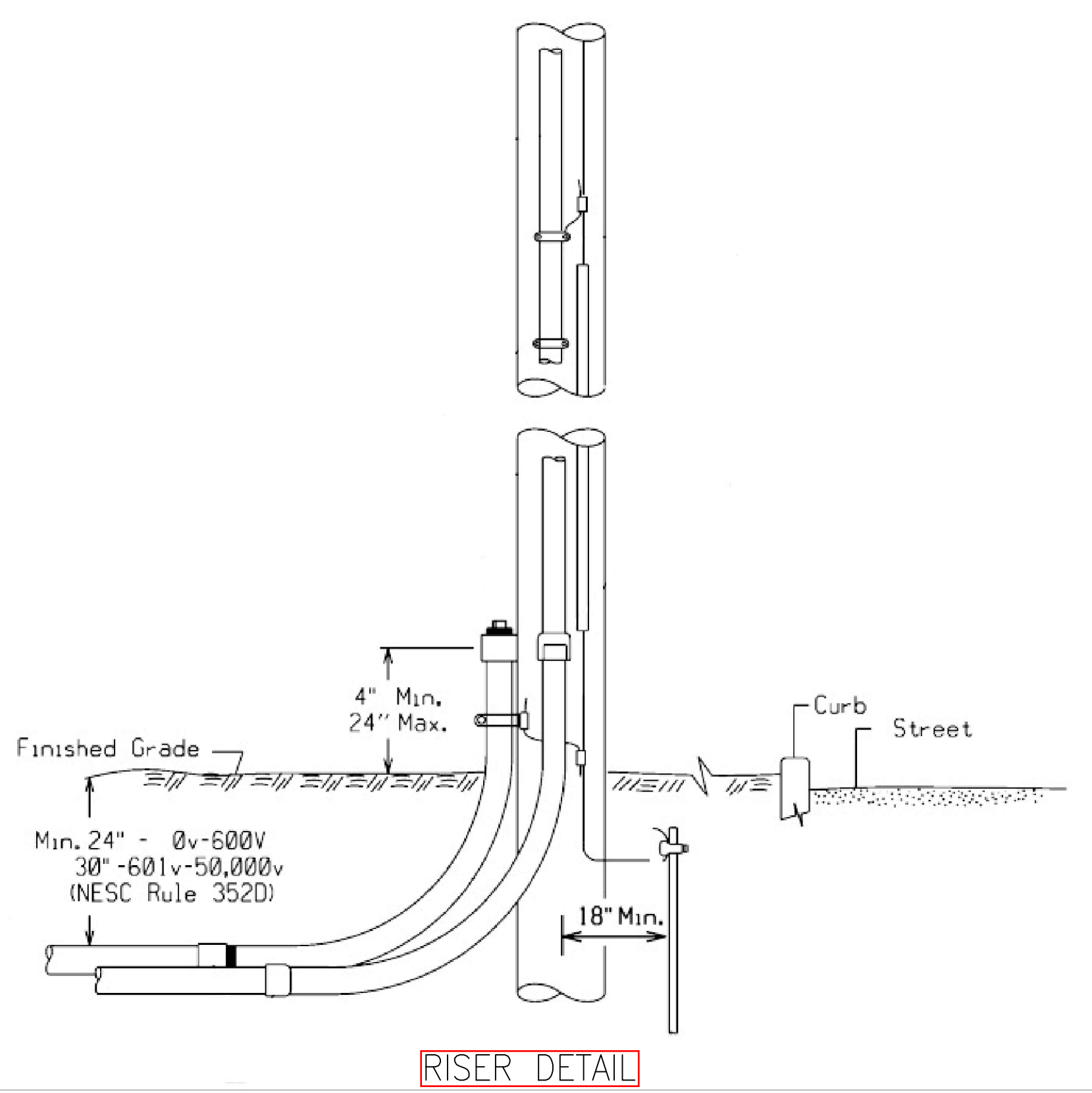
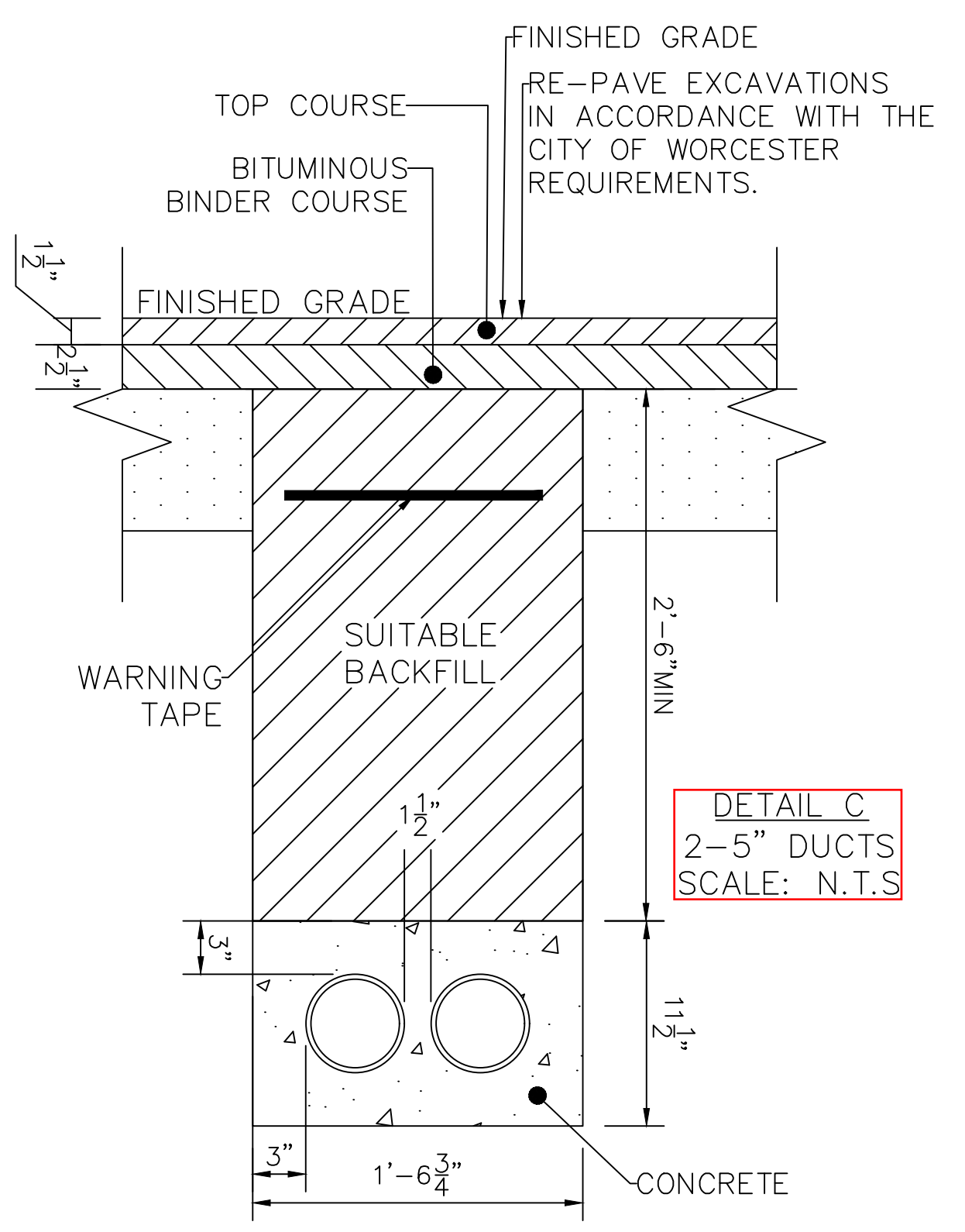
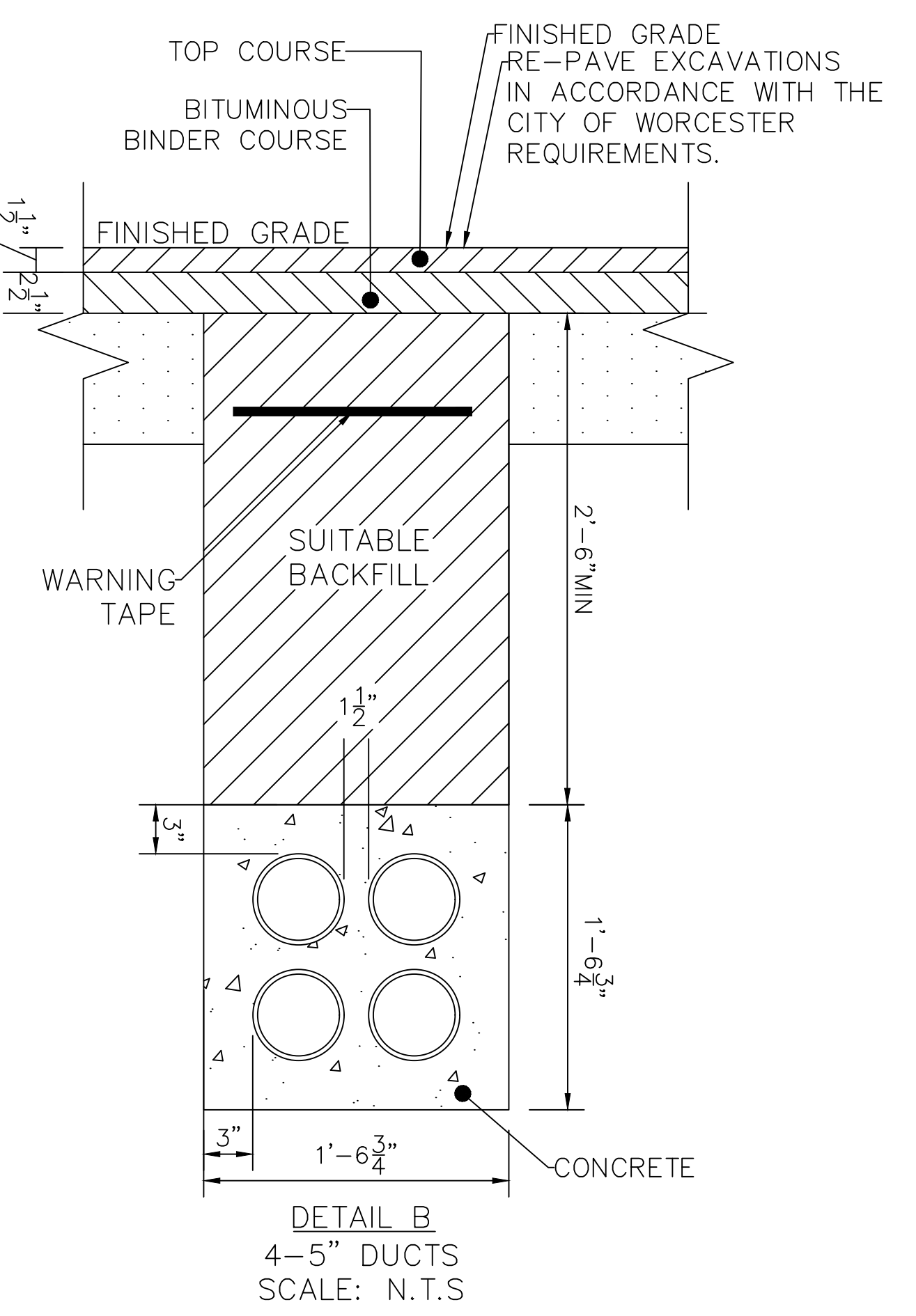
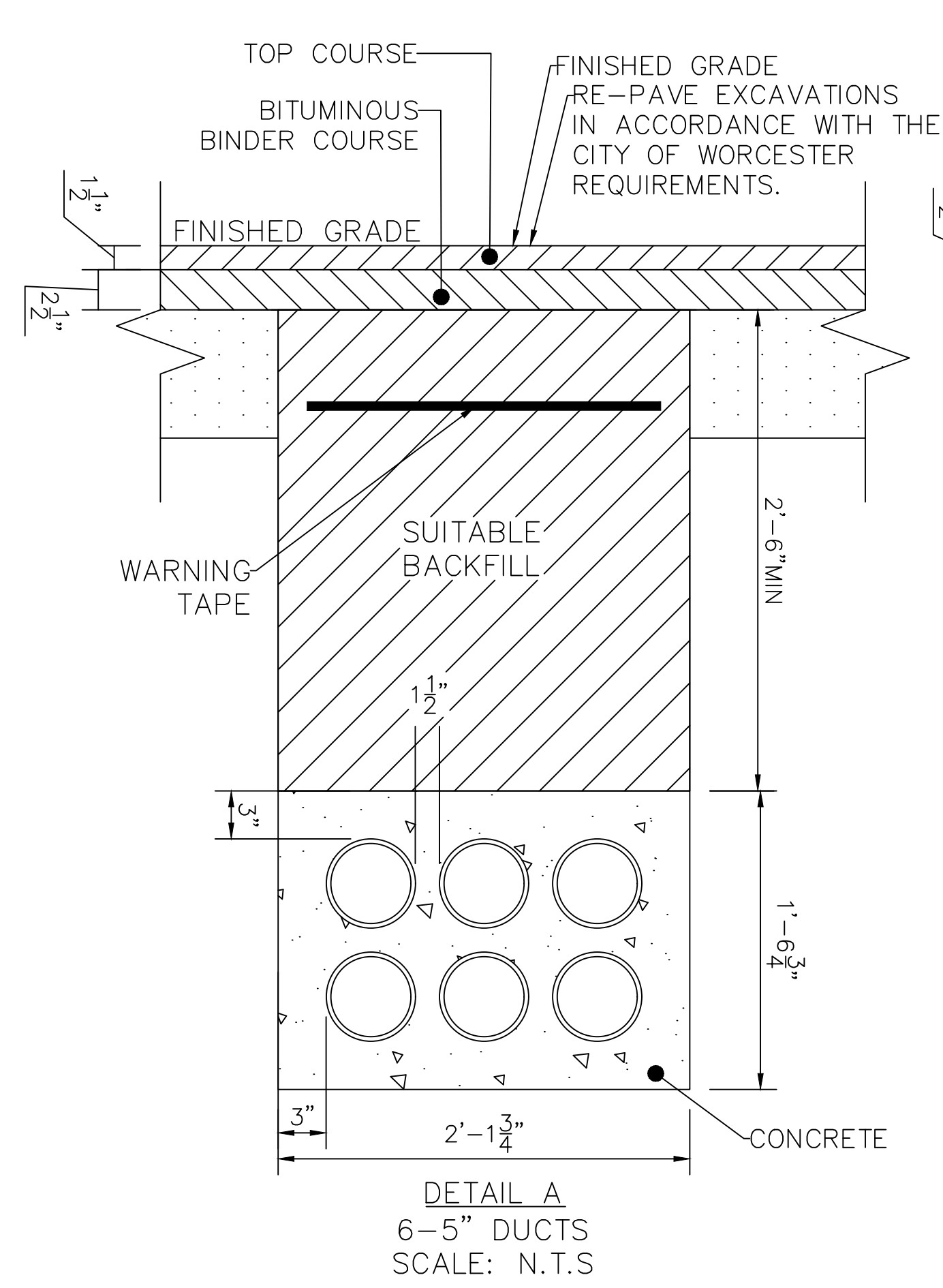

NOTE
1. FOR MANHOLE CHIMNEY OR PRECAST RING SEE MS 3748, 3755 AND 3757. USE WITH UM14F(36" FRAME), UM14R(26"-36" RING) AND UM14C(26" COVER).
2. INSTALL 1-3/8"x1-3/8" HEAVY DUTY GALVANIZED UNISTRUT AND CABLE POSITIONING BRACKETS. UNISTRUT NEEDS TO BE PROPERLY BONDED TO THE GROUND GRID WITH A TINNED CONNECTOR AND 4/0 CABLE.

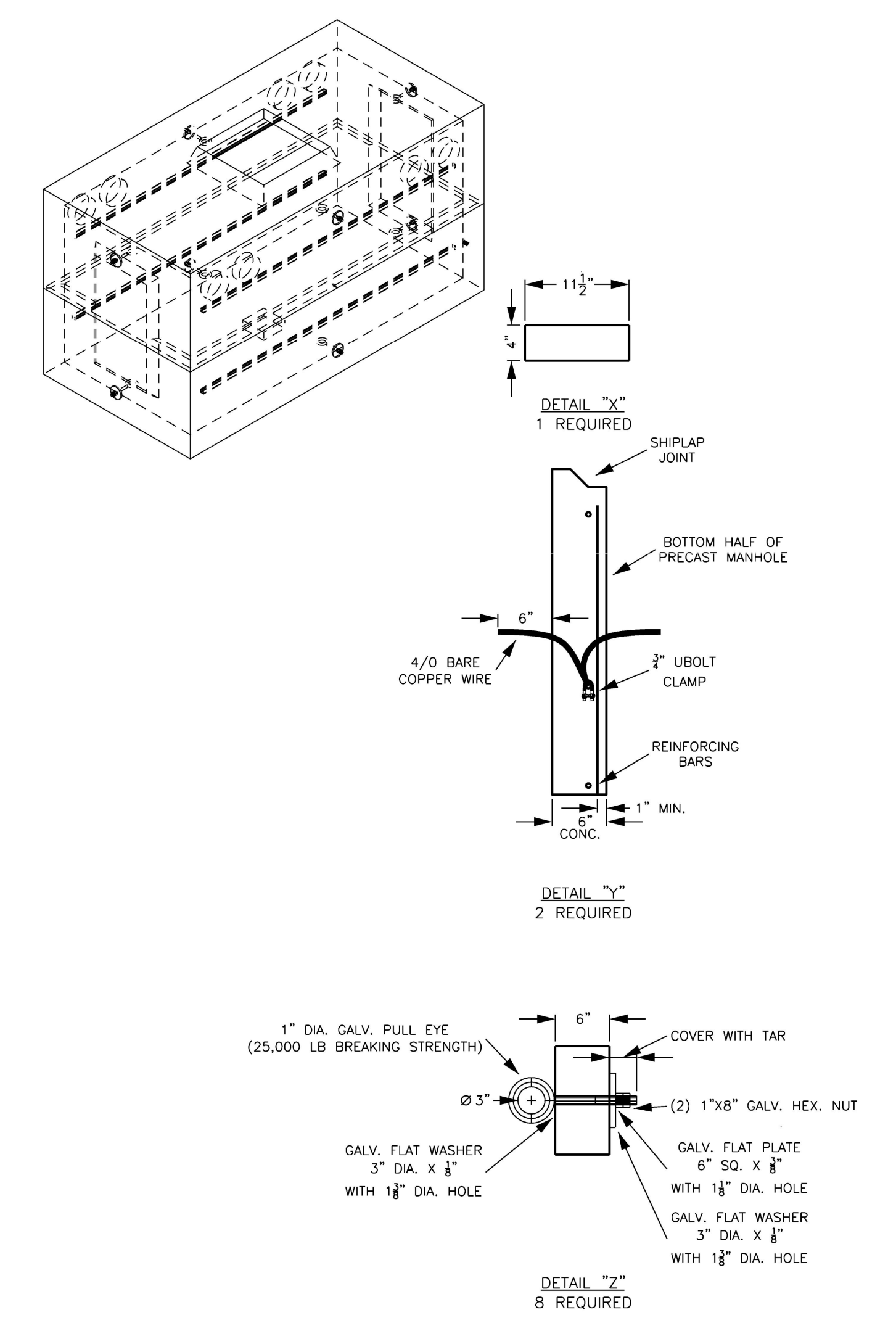

TYPICAL 2 WAY MANHOLE DETAIL

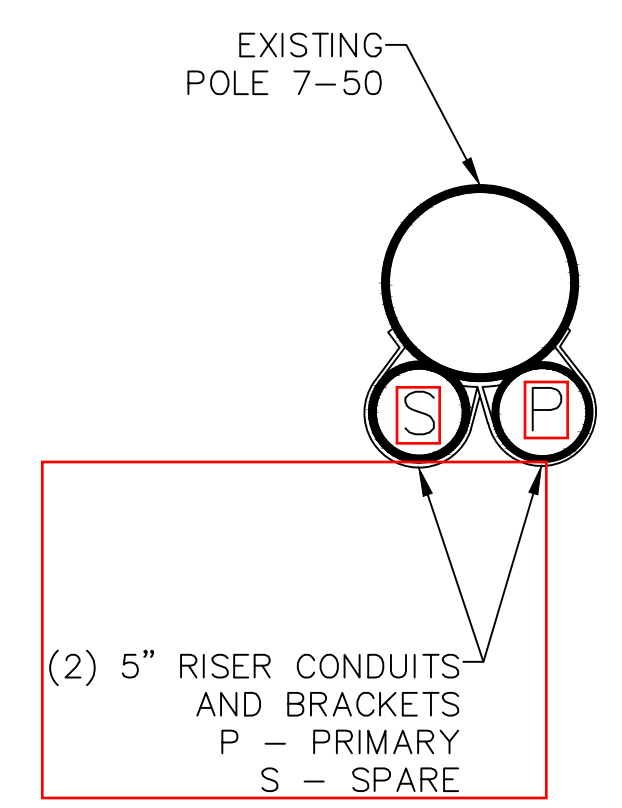
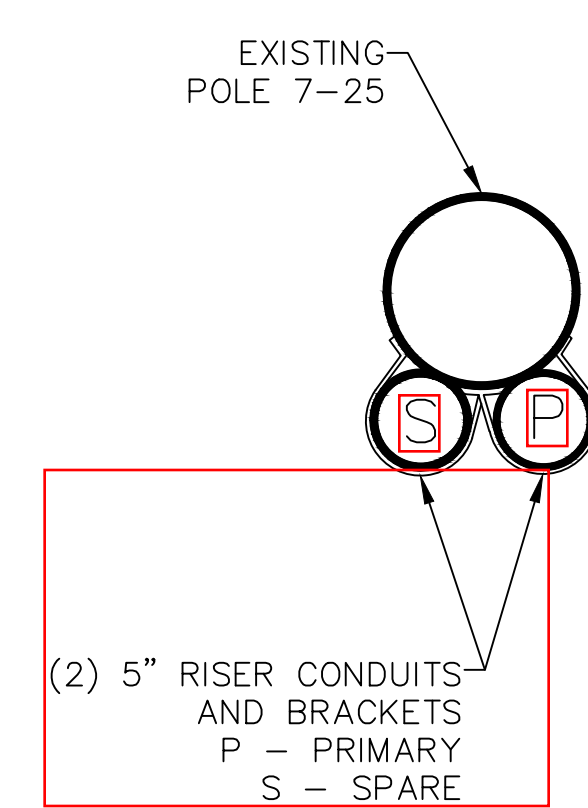

124 Grove St. Franklin, MA 02038		PROJECT NO: 270728								
DESIGNED	AS	CHECKED	APPROVED	REVIEW 1	REVIEW 2	DATE: 3/24/21	SCALE: N.T.S.		DET-2 WR#23303524	REV. 0
REV	DESCRIPTION	DATE	DES	CHK	APP					

#48 DAMON RD

18D-035-001

OWNER: KERRYMAN PARTNERSHIP

P.O. BOX 60266, FLORENCE MA 01062

PATCH EAST OF LANE PLANT ROAD

18D-057-001

OWNER: CITY OF NORTHAMPTON

210 MAIN ST, NORTHAMPTON MA 01060

#55 DAMON RD

18D-065-001

OWNER: ROBERT S. THOMAS

55 DAMON RD, NORTHAMPTON MA 01060

#137 DAMON RD

18D-005-001

OWNER: EASTHAMPTON MAHADEV LLC

8 KINSBERRY WAY, EASTHAMPTON MA 01027



CITY OF NORTHAMPTON, MASSACHUSETTS
DEPARTMENT OF PUBLIC WORKS
125 Locust Street
Northampton, MA 01060

413-587-1570
Fax 413-587-1576

Donna LaScaleia
Director

Memorandum

To: Donna LaScaleia, Director of Public Works

From: David Veleta, City Engineer

Date: April 27, 2021

Re: Council Order 21.238 – Petition for Joint Ownership Pole Install No. 23303524 – Damon Road Reconstruction Project MassDOT No. 608236 – Damon Road

Approved 4-27-21 M

I have reviewed Department of Public Works (DPW) records and submittals including images, sketches and reconstruction plans for MassDOT Damon Road project No. 608236. This petition includes the proposed installation of one (1) joint ownership (JO) pole shared between National Grid and Verizon, referenced in City Council Order 21.238.

One (1) pole on Damon Road, numbered 9-50, is proposed. This pole is to be located at a point approximately 154 easterly of the intersection of River Run and Damon Road as shown in the application sketch and provides intermediate support for overhead wires spanning between existing poles.

The proposed pole is located within the existing roadway pavement and shall not be placed until the new, relocated curbing associated with the project is installed. The pole shall be placed with a minimum 1.5' horizontal offset between the face of the new curb and the face of the pole. A minimum 3' clearance between the back of the pole and the back of the new sidewalk is necessary to meet minimum ADA compliance. The sketch shows a proposed guy wire to the north, which must not interfere with the required ADA sidewalk clearance. The pole shall be placed with a minimum five-foot horizontal offset from the existing water service line for 104 Damon Road.

A valid trench permit approved by the DPW is required before work at this location commences.

nationalgrid

March 23, 2021

The City Council of Northampton, Massachusetts

To Whom It May Concern:

Enclosed please find a petition of NATIONAL GRID and VERIZON, covering joint NATIONAL GRID-VERIZON pole location(s)

If you have any questions regarding this permit, please contact:

Daniel Lopez-Velez 774-235-2603

Please notify National Grid's **Lisa Ayres** of the hearing date / time.

If this petition meets with your approval, please return an executed copy to each of the above-named Companies.

National Grid: Lisa Ayres; 1101 Turnpike Street; North Andover, MA 01845
978-725-1418

Very truly yours,

Jim Kehrer/lla

Jim Kehrer
Supervisor, Distribution Design

Enclosures

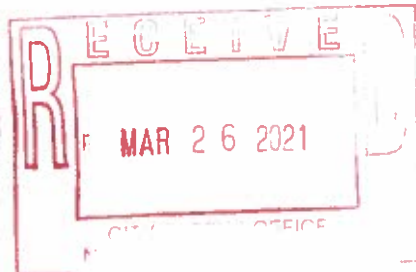

Questions contact - Daniel Lopez-Velez 774-235-2603
PETITION FOR JOINT OR IDENTICAL POLE LOCATIONS

North Andover, Massachusetts

To the City Council
Of Northampton, Massachusetts

Massachusetts Electric Company d/b/a NATIONAL GRID and Verizon New England, Inc. requests permission to locate poles, wires, and fixtures, including the necessary sustaining and protecting fixtures, along and across the following public way:

Damon Rd. - National Grid to install (1) JO pole 9-50 on Damon Rd. beginning at a point approximately 26 feet southeast of the centerline of the intersection of River Run and Damon Rd. and continuing approximately 154 feet in an east direction.

Location approximately as shown on plan attached.

Wherefore it prays that after due notice and hearing as provided by law, it be granted a location for and permission to erect and maintain poles and wires, together with such sustaining and protecting fixtures as it may find necessary, said poles to be erected substantially in accordance with the plan filed herewith marked – Damon Rd. - Northampton, Massachusetts.

23303524

Also, for permission to lay and maintain underground laterals, cables, and wires in the above or intersecting public ways for the purpose of making connections with such poles and buildings as each of said petitioners may desire for distributing purposes.

Your petitioner agrees to reserve space for one cross-arm at a suitable point on each of said poles for the fire, police, telephone, and telegraph signal wires belonging to the municipality and used by it exclusively for municipal purposes.

Massachusetts Electric Company d/b/a
NATIONAL GRID *Jim Kehrer/lla*
BY _____
Engineering Department

VERIZON NEW ENGLAND, INC.
BY *Albert F. Bessette*
Manager / Right of Way

Dated: March 19, 2021

Damon Rd. - Pole 9-50

Questions contact – Daniel Lopez-Velez 774-235-2603

ORDER FOR JOINT OR IDENTICAL POLE LOCATIONS

To the City Council - Northampton, Massachusetts

Notice having been given and public hearing held, as provided by law,
IT IS HEREBY ORDERED:

that Massachusetts Electric Company d/b/a NATIONAL GRID and VERIZON NEW ENGLAND INC. (formerly known as NEW ENGLAND TELEPHONE AND TELEGRAPH COMPANY) be and they are hereby granted joint or identical locations for and permission to erect and maintain poles and wires to be placed thereon, together with such sustaining and protecting fixtures as said Companies may deem necessary, in the public way or ways hereinafter referred to, as requested in petition of said Companies dated the 19th day of March 2021.

All construction under this order shall be in accordance with the following conditions:

Poles shall be of sound timber, and reasonable straight, and shall be set substantially at the points indicated upon the plan marked – Damon Rd. - Northampton, Massachusetts.

23303524 Filed with this order:

There may be attached to said poles by Massachusetts Electric Company d/b/a NATIONAL GRID and Verizon New England Inc. such wires, cables, and fixtures as needed in their business and all of said wires and cables shall be placed at a height of not less than twenty (20) feet from the ground.

The following are the public ways or part of ways along which the poles above referred to may be erected, and the number of poles which may be erected thereon under this order:

Damon Rd. - National Grid to install (1) JO pole 9-50 on Damon Rd. beginning at a point approximately 26 feet southeast of the centerline of the intersection of River Run and Damon Rd. and continuing approximately 154 feet in an east direction.

Also, for permission to lay and maintain underground laterals, cables, and wires in the above or intersecting public ways for the purpose of making connections with such poles and buildings as each of said petitioners may desire for distributing purposes.

I hereby certify that the foregoing order was adopted at a meeting of the
Of the City/Town of _____, Massachusetts held on the _____ day of _____ 20 .

Massachusetts

City/Town Clerk.
20 .

Damon Rd. - Pole 9-50

Received and entered in the records of location orders of the City/Town of
Book _____ Page _____

Attest:
City/Town Clerk

I hereby certify that on _____ 20____, at _____ o'clock, M
At _____ a public hearing was held on the petition of
Massachusetts Electric Company d/b/a NATIONAL GRID and VERIZON NEW ENGLAND,
INC. for permission to erect the poles, wires, and fixtures described in the order herewith recorded,
and that we mailed at least seven days before said hearing a written notice of the time and place of
said hearing to each of the owners of real estate (as determined by the last preceding assessment
for taxation) along the ways or parts of ways upon which the Company is permitted to erect
Poles, wires, and fixtures under said order. And that thereupon said order was duly adopted.

City/Town Clerk.

.....
.....
.....
.....

Board or Council of Town or City, Massachusetts

CERTIFICATE

I hereby certify that the foregoing is a true copy of the location order and certificate of
hearing with notice adopted by the _____ of the City of
Massachusetts, on the _____ day of 20____ and recorded with the records of location orders
of the said City, Book _____, and Page _____. This certified copy is made under the
provisions of Chapter 166 of General Laws and any additions thereto or amendments thereof.

Attest:
City/Town Clerk

JO POLES

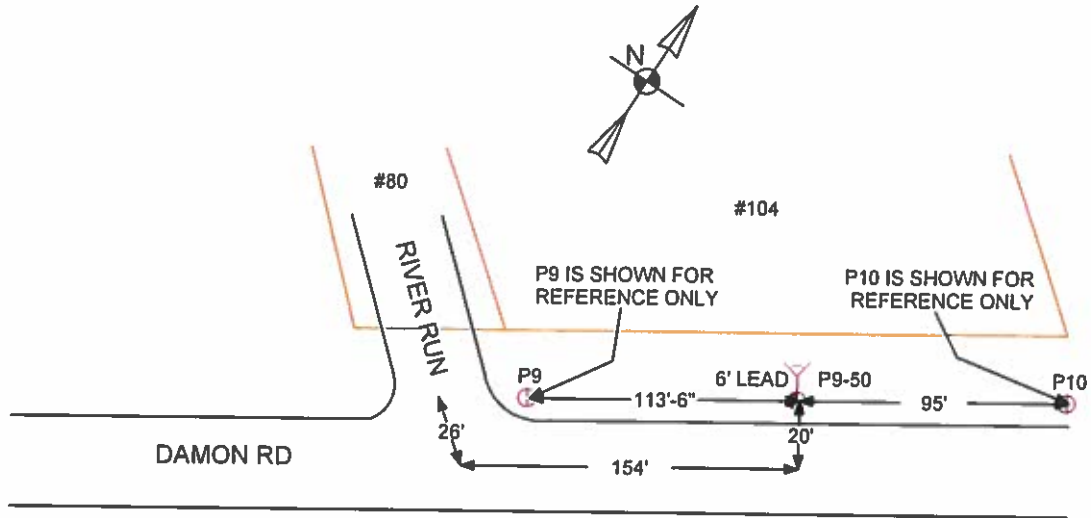

DANIEL LOPEZ
TRC
774-235-2603

JOINT OWNED POLE PETITION	nationalgrid And Verizon New England, Inc.
<input checked="" type="radio"/> Proposed NGRID Pole Locations	Date: 3/15/2021
<input type="radio"/> Existing NGRID Pole Locations	Plan Number: WR# 23303524
<input checked="" type="radio"/> Proposed J.O. Pole Locations	To Accompany Petition Dated: 3/15/2021
<input type="radio"/> Existing J.O. Pole Locations	To The: City Of Northampton
<input checked="" type="radio"/> Existing Telephone Co. Pole Locations	For Proposed: JO Pole: P9-50 Location: Damon Rd
<input type="radio"/> Existing NGRID Pole Location To Be Made J.O.	Date Of Original Grant: N/A
<input checked="" type="checkbox"/> Existing Pole Locations To Be Removed	
DISTANCES ARE APPROXIMATE	

JO POLES

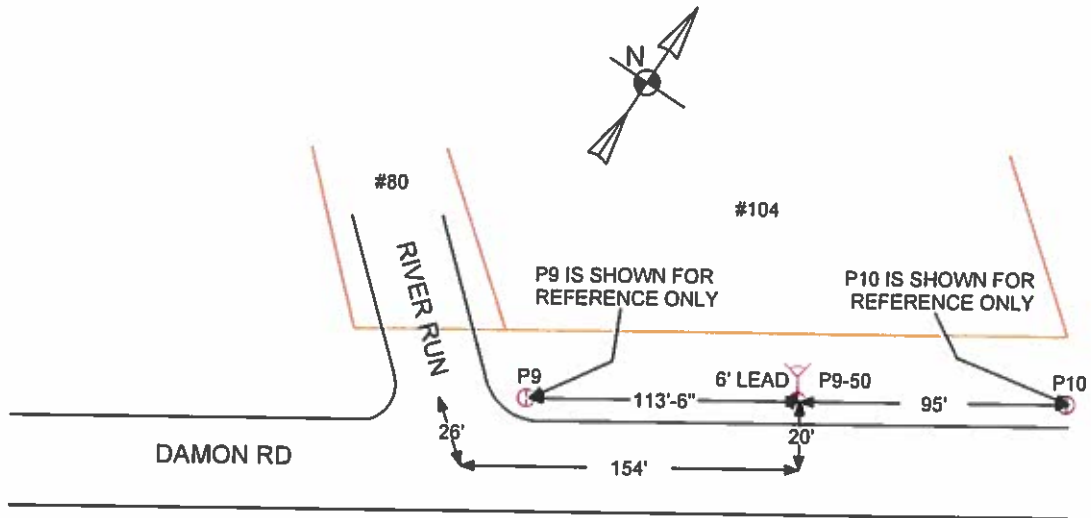

DANIEL LOPEZ
TRC
774-235-2603

JOINT OWNED POLE PETITION	nationalgrid And Verizon New England, Inc.
<input checked="" type="checkbox"/> Proposed NGRID Pole Locations	Date: 3/15/2021
<input type="checkbox"/> Existing NGRID Pole Locations	Plan Number: WR# 23303524
<input checked="" type="checkbox"/> Proposed J.O. Pole Locations	To Accompany Petition Dated: 3/15/2021
<input type="checkbox"/> Existing J.O. Pole Locations	To The: City Of Northampton
<input checked="" type="checkbox"/> Existing Telephone Co. Pole Locations	For Proposed: JO Pole: P9-50 Location: Damon Rd
<input type="checkbox"/> Existing NGRID Pole Location To Be Made J.O.	Date Of Original Grant: N/A
<input checked="" type="checkbox"/> Existing Pole Locations To Be Removed	
DISTANCES ARE APPROXIMATE	

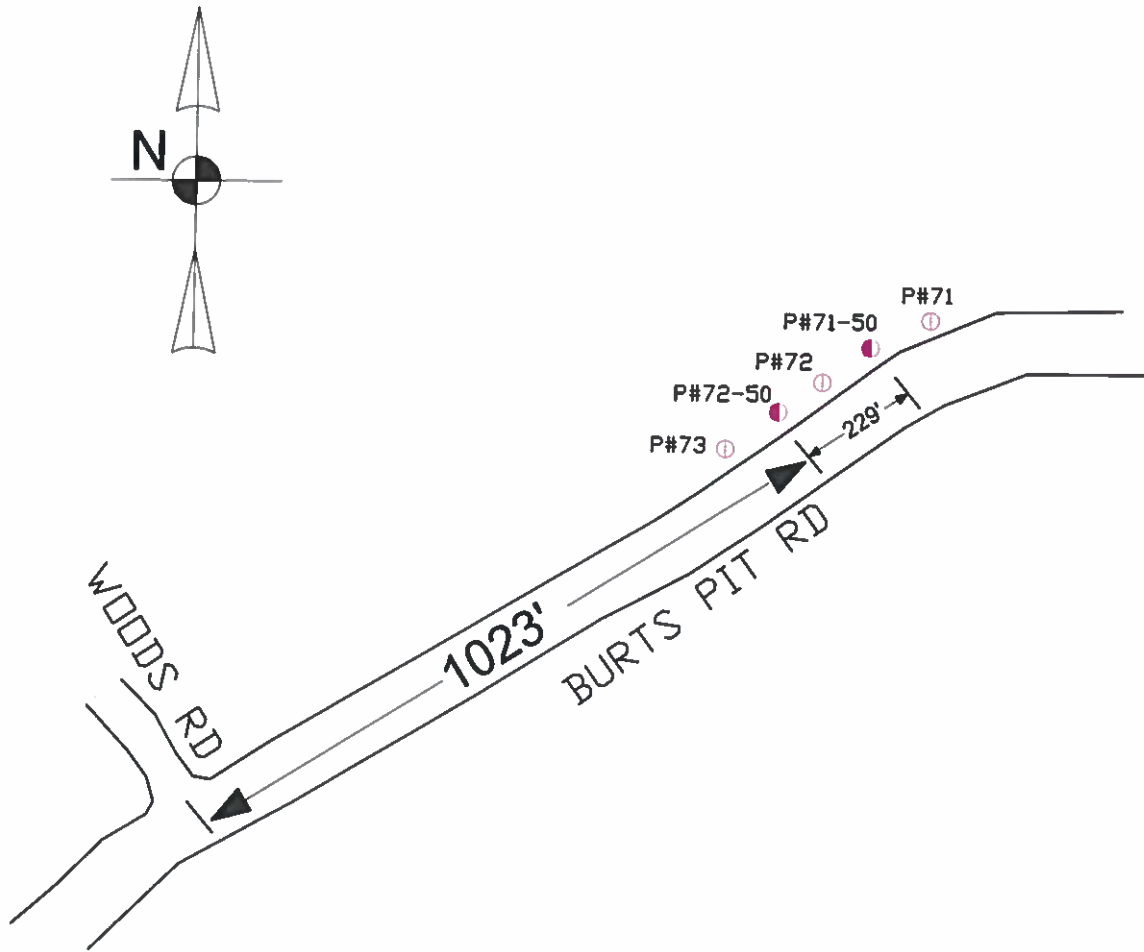

POLE PETITION

nationalgrid

- Proposed NGRID Pole Locations
- Existing NGRID Pole Locations
- Proposed J.O. Pole Locations
- ⊕ Existing J.O. Pole Locations
- + Existing Telephone Co. Pole Locations
- ⊗ Existing NGRID Pole Location To Be Made J.O.
- ⊗ Existing Pole Locations To Be Removed

Date: 2-5-21

Plan Number: WR#30025210

To Accompany Petition Dated:

To The: TOWN Of NORTHAMPTON

For Proposed: 2 Pole: JO Location: BURTS PIT RD

Date Of Original Grant:

DISTANCES ARE APPROXIMATE



CITY OF NORTHAMPTON, MASSACHUSETTS
DEPARTMENT OF PUBLIC WORKS
125 Locust Street
Northampton, MA 01060

413-587-1570
Fax 413-587-1576

Donna LaScaleia
Director

Memorandum

To: Donna LaScaleia, DPW Director *Approved 4-27-21* 
From: Kris Baker, P.E., Civil Engineer
Date: April 26, 2021
Re: Petition for Joint or Identical Pole Locations No. 30025210

National Grid is proposing to install two (2) Jointly Owned Poles on Burts Pit Road: one approximately 1,023 feet east from the centerline of the intersection with Woods Road, and one approximately 229 feet east from that pole, as staked. A site visit was conducted on April 26, 2021 with the developer and a National Grid representative to discuss the proposed work as well as to determine the field location of the proposed poles in relation to the existing water and sewer stubs to the properties. The existing water valves and sewer cleanouts were field located and marked by the Water Division and the Sewer & Drain Division, respectively.

The proposed location of pole #72-50 is six (6) feet from the existing water service line. The proposed location of pole #71-50 is five (5) feet from the existing water service line. The poles are located more than five (5) feet from existing sewer service lines and more than ten (10) feet from the existing water main, drain pipes, sewer main, and manhole structures. The poles should therefore be set at the staked locations and there will be no utility conflicts.

There are no trees in the vicinity of the proposed poles and no apparent interference of trees with proposed overhead wires.

A valid "Excavation/Trench Permit" issued by the DPW is required prior to construction.



City of Northampton
MASSACHUSETTS

In the City Council, May 6, 2021

Upon the Recommendation of: Councilor Karen Foster
 Councilor Marianne LaBarge
 Councilor Rachel Maiore
 Councilor Gina-Louise Sciarra

R-21.266 A RESOLUTION IN SUPPORT OF WORKERS OF THE HAMPSHIRE GAZETTE

WHEREAS: the *Daily Hampshire Gazette* has been an institution in our community for nearly 235 years; and

WHEREAS: the *Gazette* has tirelessly chronicled the triumphs, tragedies and history of the people of the Connecticut River Valley, keeping the public informed and proving itself invaluable in exposing injustice in Northampton and beyond; and

WHEREAS: local news is critical to a working democracy, ensuring communities have accurate information, uplifting marginalized voices, and providing crucial oversight over local governance; and

WHEREAS: Northampton's municipal government relies on the *Gazette* to communicate issues, events, projects and public notices to the public; and

WHEREAS: the *Gazette* is made by its workers and this Council appreciates how they have persevered through a global pandemic, despite losing over half their staff, to keep the Valley informed of vital information, and in the early stages of the pandemic making the important decision to provide coronavirus-related news to our community at no charge to readers; and

WHEREAS: the *Gazette's* unionized workers have been in contract negotiations with the *Gazette's* parent company, Newspapers of New England, for nearly two years; and

WHEREAS: the *Gazette's* workers deserve protections against the outsourcing of their work as well as a contract that provides for a fair wage with cost of living increases and remains intact no matter who owns the newspaper; and

WHEREAS: the *Gazette's* workers who were laid-off deserve the opportunity to be rehired if their positions return to the paper;

NOW, THEREFORE BE IT RESOLVED, that the Northampton City Council stands in solidarity with the workers of the *Daily Hampshire Gazette*, and asks Newspapers of New England to swiftly bargain a contract that improves the well-being of its workers, which will strengthen the newspaper and help it continue for years to come. We call on Newspapers of New England to invest in the *Gazette* and its workers, and to make a commitment to local ownership;

BE IT FURTHER RESOLVED that the Northampton City Council recognizes the importance of the *Daily Hampshire Gazette* to our region, and encourages our local community to support the *Gazette* to help maintain the financial viability of this critical source of local news;

BE IT FURTHER RESOLVED that the Administrative Assistant to the City Council shall send a copy of this Resolution to U.S. Senators Elizabeth Warren and Ed Markey, U.S. Representative Jim McGovern, Senator Jo Comerford, Representative Lindsay Sabadosa, Newspaper of New England President and CEO Aaron Julien, *Daily Hampshire Gazette* Publisher Shawn Palmer, Editor-in-Chief Joan Livingston and the Pioneer Valley News Guild.

In the City Council, May 6, 2021

Upon the Recommendation of: Councilor Rachel Maiore and Councilor Michael J. Quinlan, Jr

R-21.267

**A Resolution In Support of the Recommendations of the
Northampton Policing Review Commission**

WHEREAS, the Mayor and City Council of Northampton committed to “actions at the local level to combat public health crisis of systemic racism” by creating the Northampton Policing Review Commission and charging the Commission to study these complex issues and recommend reforms to the current organizational and oversight structures, municipal funding allocations, and policies and ordinances that together can transform how the city delivers policing services while ensuring community safety equitably and justly for all, and

WHEREAS, The Northampton Policing Review Commission met that charge through dedicated work, holding three public hearings, more than 70 meetings of the full commission and sub-committees, and countless hours of research, and

WHEREAS, The Northampton Policing Review Commission’s final report underscored the importance of building a new system that reflects Northampton’s values and is designed to promote the care, health, and well-being of everyone in our community at no one’s expense.

WHEREAS, The Northampton Policing Reviewing Commission in the Reimaging Safety report states, “the Department of Community Care be established and funded in FY 2022 and fully operational in FY 2023,” and

WHEREAS, The Northampton Policing Reviewing Commission in the Reimaging Safety report states, “the Commission recommends that this department be intentionally independent from the Northampton Police Department, but open to collaboration with all City departments. Given the nature of the responsibilities we are recommending this department take on, and the recognition of racism itself as a health crisis, we advocate that the department be situated underneath the Board of Health,”

NOW, THEREFORE BE IT RESOLVED, that the Northampton City Council supports the recommendations outlined in the Final Report of the Northampton Policing Review Commission.

BE IT FURTHER RESOLVED, that the Northampton City Council commends the members of the Northampton Policing Review Commission for their effort and dedication to Northampton.

BE IT FURTHER RESOLVED, that the Northampton City Council urges the Mayor to establish a Department of Community Care in this fiscal year and fund it by at least \$882,602 in the FY22 Budget.

BE IT FURTHER RESOLVED, that the City Council recommends that given the nature of the responsibilities that are recommended for this department to take on, and the recognition of racism itself as a health crisis, we advocate that the department be situated underneath the Board of Health.

BE IT FURTHER RESOLVED, that the Administrative Assistant to the City Council shall send a copy of this Resolution to Mayor David Narkewicz, Health Director Merridith O'Leary and The Commissioners of the Northampton Policing Review Commission.

City of Northampton

AFFIDAVIT OF WAGE COMPLIANCE

Name of Business: Cancer Connection Thrift Shop

Location of Business: 375 South Street

The Northampton City Council, in determining whether to issue, re-issue, modify, suspend or revoke a license. under G.L. c. 140, shall require that a potential or current licensee certify that they are not subject to a federal or state criminal or civil judgment, administrative citation, order or final administrative determination resulting from a violation of G.L. c. 149, c. 151, or the Fair Labor Standards Act. The City Council may require a wage bond or insurance be posted by any potential licensee who does not certify that they are not subject to a federal or state criminal or civil judgment, administrative citation, order or final administrative determination resulting from a violation of G.L. c. 149, c. 151, or the Fair Labor Standards Act. Licensees that are subject to a state or federal debarment for violation of the above laws, either voluntarily or involuntarily, or that have been prohibited from contracting with the Commonwealth or any of its agencies or subdivisions shall be prohibited from holding, or continuing to hold, licenses issued under G.L. c. 140, for the entire period of debarment or other stated time period.

Applicants must check box 1 or box 2 as applicable and must sign this Form, certifying compliance with the requirements set out in this Form. This Form must be included with the application.

AFFIDAVIT: (Choose 1 below)

- This License applicant is not subject to a federal or state criminal or civil judgment, administrative citation, order or final administrative determination resulting from a violation of G.L. c. 149, c. 151, or the Fair Labor Standards Act within the last three years.
- This License applicant is subject to a federal or state criminal or civil judgment, administrative citation, order or final administrative determination resulting from a violation of G.L. c. 149, c. 151, or the Fair Labor Standards Act within the last three years. This applicant will provide a wage bond or wage insurance for the period of the license.

Christine Quinn
(Typed or printed name of applicant)

Christine Quinn
(Signature)

City of Northampton
Application for Annual License

NORTHAMPTON, MASS., _____

To the Honorable City Council of the City of Northampton:

The undersigned respectfully petitions your honorable body for a License as follows:

Name of Business: **Cancer Connection Thrift Shop**

Type of License: **Secondhand Dealer**

Location of Business: **375 South Street**

Print Name of Applicant: (V) Christine Quinn

Signature of Applicant: (V) Christine Quinn

Address of Applicant: (V) No. 20 Street Zabek Dr. Easthampton MA
01027

In City Council, _____

Referred to Committee on Licenses.

ATTEST:

City Clerk

In Committee on Licenses, _____

Voted to recommend that Petition ___ be
granted, _____ not granted

ATTEST:

Clerk

In City Council, _____ (date)

Voted that Petition be _____ granted
_____ not granted

Attest: _____ Clerk to City Council

City of Northampton

STATEMENT OF ALL TAXES FILED AND PAID

Name of Business: Cancer Connection Thrift Shop

Location of Business: 375 South Street

The license (as a/for a) Secondhand Dealer will not be issued unless this certification clause is signed by the applicant listed on the license.

I, Christine Quinn (print name of owner or authorized agent of the business) certify under the penalties of perjury that I, to my best knowledge and belief, have filed all state tax returns and paid all state taxes as required under law.

Christine Quinn

Signature of Owner or Agent

_____ or 

Social Security Number

Federal Identification Number

Your social security number will be furnished to the Massachusetts Department of Revenue to determine whether you have met tax filing or tax payment obligations. Licenses who fail to correct their non-filing or delinquency will be subject to license suspension or revocation. This request is made under the authority of Massachusetts General Law, chapter 62C, section 49A.

City of Northampton
Treasurer/Collector's Office
Permit Denial Form

Revised 11-30-2018

REQUESTED BY: **Pamela L. Powers, City Clerk**

Name of Person, Corporation or Business: **Cancer Connection Thrift Shop**

Location of Property, Service or Address: **375 South Street, Northampton, MA 01060**

All permits denied for outstanding amounts must receive confirmation of good standing from the Treasurer/Collector's Office PRIOR to issuance of the permit.

For Tax Collector's/Treasurer's Office Use Only

Please list below any tax, assessed to your office that is unpaid for twelve (12) months or more after its due date, unless there is a pending abatement or appeal before the Appellate Tax Board, for the person, corporation, or business entity noted above.

This is a tax exempt entity for FY21 and no amounts are outstanding

Signed: Kristine Bissell

Dated: April 7, 2021

Adopted 5-21 1992 [Ch14 S.14-21 of the 1977 Code]
Denial/Revocation of License

City of Northampton



MAYOR DAVID J. NARKEWICZ

City of Northampton

Office of the Mayor

210 Main Street Room 12

Northampton, MA 01060-3199

(413) 587-1249 Fax: (413) 587-1275

mayor@northamptonma.gov

DATE: May 6, 2021

TO: City Council

FROM: Mayor David J. Narkewicz

SUBJECT: Reappointments to Boards, Committees, and Commissions

Please find the attached reappointments to City Boards, Committees, and Commissions:

Agricultural Commission

John J. Bobala, 25 Old Ferry Road, Northampton

Term: July 2021-June 2024

Reappointment

Richard E. Jaescke, 774 Bridge Road, Northampton

Term: July 2021-June 2024

Reappointment

Robert Vollinger, 460 North Farms Road, Florence

Term: July 2021-June 2023

Reappointment

Earle "Chip" Parsons, 137 Mill Valley Road, Hadley

Term: July 2021-June 2023

Reappointment

Central Business Architecture Committee

Joseph Blumenthal, 39 Chapel St., Northampton

Term: July 2021-June 2024

Reappointment

Urban Forestry Commission

Susan Lofthouse, 15 Stoddard Street, Northampton

Term: July 2021-June 2024

Reappointment

Council on Aging

Robert Dionne, 87 Vernon Street, Northampton

Term: July 2021-June 2024

Reappointment

Jeanne Hoose, 36 South Park Terrace, Northampton

Term: July 2021-June 2024

Reappointment

Historical Commission

Dylan Gafney, 23 Marshall Street, Northampton

Term: July 2019-June 2022

Reappointment

Barbara Blumenthal, 39 Chapel Street, Northampton

Term: July 2021-June 2024

Reappointment

Housing Partnership

Julio Alves, 35 Fort Hill Terrace, Northampton

Term: July 2021- June 2024

Reappointment

James Reis, 108 Coles Meadow Road, Northampton

Term: July 2021-June 2024

Reappointment

Parks and Recreation Commission

Julia Chevan, 8 Cosmian Avenue, Florence

Term: July 2020-June 2023

Reappointment

Planning Board

George Kohout, Full Member, 234 State Street, Northampton

Term: July 2021-June 2024

Reappointment

Zoning Board of Appeals

Maureen Scanlon, 197 Nonotuck Street, Florence

Term: July 2021-June 2024

Reappointment



City of Northampton Application for Appointment to Boards, Committees and Commissions

Name: John J Bobala
 Address: 25 Old Ferry Rd Northampton MA 01060
 Email: J Bobala@yahoo.com
 Home Phone: 413-586-2704 Work: RETIRED Cell: 413-335-8970
 Occupation: Vocational Inst Years lived in Northampton: 70 yrs
 Northampton Resident: Yes No

Please indicate the Committee(s) you have interest serving on: *(Appointment subject to vacancies)*

<input checked="" type="checkbox"/> Agricultural Commission	<input type="checkbox"/> License Commission
<input type="checkbox"/> Almoners, Board of	<input type="checkbox"/> Municipal Affordable Housing Trust Fund Board of Trustees
<input type="checkbox"/> Arts Council	<input type="checkbox"/> Parks and Recreation Commission
<input type="checkbox"/> Assessors, Board of	<input type="checkbox"/> Planning Board
<input type="checkbox"/> Central Business Architecture Committee	<input type="checkbox"/> Public Shade Tree Commission
<input type="checkbox"/> Community Preservation Committee	<input type="checkbox"/> Public Works Commission
<input type="checkbox"/> Conservation Commission	<input type="checkbox"/> Redevelopment Authority
<input type="checkbox"/> Council on Aging	<input type="checkbox"/> Registrars, Board of
<input type="checkbox"/> Disability Commission	<input type="checkbox"/> Transportation & Parking Commission
<input type="checkbox"/> Energy & Sustainability Commission	<input type="checkbox"/> Trust Fund Committee
<input type="checkbox"/> Health, Board of	<input type="checkbox"/> Youth Commission
<input type="checkbox"/> Historical Commission	<input type="checkbox"/> Zoning Board of Appeals
<input type="checkbox"/> Housing Partnership	
<input type="checkbox"/> Human Rights Commission	

What skills and experience will you bring to this Committee assignment:

(attach additional sheet or resume if necessary)

RETIRED DAIRY FARMER

Are you currently serving or have you served on any City committee: No Yes*

*(*If yes please state what committee)*

Required: Please read the following, by signing below you state that you understand and agree:

The filing of this form does not guarantee my appointment. An application is kept on file for two (2) years; after that I must file a new application. Being appointed to a committee, board, or commission means that I am considered a Municipal Employee under MGL Chapter 268A and thereby subject to Conflict of Interest Law MGL Chapter 268A, Financial Disclosure Law MGL Chapter 268B, as well as Open Meeting Law MGL Chapter 39: Section 23B. I understand that I will take the conflict of interest test AFTER being appointed and that I also must be sworn in by the City Clerk. I will contact the appointing authority with any questions about my service. **IMPORTANT: Once this form is submitted it becomes a public document, if there is information you do not want open to the public please do not include it on this form!**

SIGNATURE

John J. Bobala

DATE

20 APR 21

Please Return Form To: Mayor@northamptonma.gov or
 David J. Narkewicz, Mayor, 210 Main Street, Northampton, MA 01060



City of Northampton Application for Appointment to Boards, Committees and Commissions

Name: Richard E. Jaescke
 Address: 774 Bridge Road
 Email: RCWlandscapes@AOL.COM
 Home Phone: 584 7898 Work: _____ Cell: 413 535 0775
 Occupation: Landscape Const/Farming Years lived in Northampton: 71
 Northampton Resident: Yes No

Please indicate the Committee(s) you have interest serving on: *(Appointment subject to vacancies)*

Agricultural Commission <input checked="" type="checkbox"/>	License Commission
Almoners, Board of	Municipal Affordable Housing Trust Fund Board of Trustees
Arts Council	Parks and Recreation Commission
Assessors, Board of	Planning Board
Central Business Architecture Committee	Public Shade Tree Commission
Community Preservation Committee	Public Works Commission
Conservation Commission	Redevelopment Authority
Council on Aging	Registrars, Board of
Disability Commission	Transportation & Parking Commission
Energy & Sustainability Commission	Trust Fund Committee
Health, Board of	Youth Commission
Historical Commission	Zoning Board of Appeals
Housing Partnership	
Human Rights Commission	

What skills and experience will you bring to this Committee assignment:

(attach additional sheet or resume if necessary)

Farmer in Northampton for 50 yrs

Are you currently serving or have you served on any City committee: _____ No Yes*

*(*If yes please state what committee)* Ag - Commission

Required: Please read the following, by signing below you state that you understand and agree:
 The filing of this form does not guarantee my appointment. An application is kept on file for two (2) years; after that I must file a new application. Being appointed to a committee, board, or commission means that I am considered a Municipal Employee under MGL Chapter 268A and thereby subject to Conflict of Interest Law MGL Chapter 268A, Financial Disclosure Law MGL Chapter 268B, as well as Open Meeting Law MGL Chapter 39: Section 23B. I understand that I will take the conflict of interest test AFTER being appointed and that I also must be sworn in by the City Clerk. I will contact the appointing authority with any questions about my service. **IMPORTANT: Once this form is submitted it becomes a public document, if there is information you do not want open to the public please do not include it on this form!**

SIGNATURE Richard Jaescke DATE 4/20/2021

Please Return Form To: Mayor@northamptonma.gov or
 David J. Narkewicz, Mayor, 210 Main Street, Northampton, MA 01060



City of Northampton Application for Appointment to Boards, Committees and Commissions

Name: Robert Vollinger
 Address: 460 North Farms Rd. Florence MA.
 Email: RVollinger@gmail.com
 Home Phone: 413-268-3556 Work: _____ Cell: 413-626-4571
 Occupation: Farmer Years lived in Northampton: 30
 Northampton Resident: Yes No Farm in Northampton

Please indicate the Committee(s) you have interest serving on: *(Appointment subject to vacancies)*

Agricultural Commission <input checked="" type="checkbox"/>	License Commission
Almoners, Board of	Municipal Affordable Housing Trust Fund Board of Trustees
Arts Council	Parks and Recreation Commission
Assessors, Board of	Planning Board
Central Business Architecture Committee	Public Shade Tree Commission
Community Preservation Committee	Public Works Commission
Conservation Commission	Redevelopment Authority
Council on Aging	Registrars, Board of
Disability Commission	Transportation & Parking Commission
Energy & Sustainability Commission	Trust Fund Committee
Health, Board of	Youth Commission
Historical Commission	Zoning Board of Appeals
Housing Partnership	
Human Rights Commission	

What skills and experience will you bring to this Committee assignment:
(attach additional sheet or resume if necessary)

Farmer for over 30 years

Are you currently serving or have you served on any City committee: _____ No Yes*
*(*If yes please state what committee)* Ag.

Required: Please read the following, by signing below you state that you understand and agree:
 The filing of this form does not guarantee my appointment. An application is kept on file for two (2) years; after that I must file a new application. Being appointed to a committee, board, or commission means that I am considered a Municipal Employee under MGL Chapter 268A and thereby subject to Conflict of Interest Law MGL Chapter 268A, Financial Disclosure Law MGL Chapter 268B, as well as Open Meeting Law MGL Chapter 39: Section 23B. I understand that I will take the conflict of interest test AFTER being appointed and that I also must be sworn in by the City Clerk. I will contact the appointing authority with any questions about my service. **IMPORTANT: Once this form is submitted it becomes a public document, if there is information you do not want open to the public please do not include it on this form!**

SIGNATURE Robert Vollinger DATE 4/20/21

Please Return Form To: Mayor@northamptonma.gov or
 David J. Narkewicz, Mayor, 210 Main Street, Northampton, MA 01060



City of Northampton

Application for Appointment to Boards, Committees and Commissions

Name: Earle m. PARSONS
 Address: 137 mill valley Rd Hadley
 Email: ChipJDe@aol.com
 Home Phone: 584-8251 Work: _____ Cell: 413-219-7819
 Occupation: Farmer Years lived in Northampton: 14
 Northampton Resident: Yes No

Please indicate the Committee(s) you have interest serving on: *(Appointment subject to vacancies)*

<input checked="" type="checkbox"/> Agricultural Commission	License Commission
Almoners, Board of	Municipal Affordable Housing Trust Fund Board of Trustees
Arts Council	Parks and Recreation Commission
Assessors, Board of	Planning Board
Central Business Architecture Committee	Public Shade Tree Commission
Community Preservation Committee	Public Works Commission
Conservation Commission	Redevelopment Authority
Council on Aging	Registrars, Board of
Disability Commission	Transportation & Parking Commission
Energy & Sustainability Commission	Trust Fund Committee
Health, Board of	Youth Commission
Historical Commission	Zoning Board of Appeals
Housing Partnership	
Human Rights Commission	

What skills and experience will you bring to this Committee assignment:

(attach additional sheet or resume if necessary)

Have farmed with my family for many years
in the meadows. INVOLVED in ag organizations include
the Three County Fair

Are you currently serving or have you served on any City committee: _____ No _____ Yes*

*(*If yes please state what committee)* Ag Commission

Required: Please read the following, by signing below you state that you understand and agree:
 The filing of this form does not guarantee my appointment. An application is kept on file for two (2) years; after that I must file a new application. Being appointed to a committee, board, or commission means that I am considered a Municipal Employee under MGL Chapter 268A and thereby subject to Conflict of Interest Law MGL Chapter 268A, Financial Disclosure Law MGL Chapter 268B, as well as Open Meeting Law MGL Chapter 39: Section 23B. I understand that I will take the conflict of interest test AFTER being appointed and that I also must be sworn in by the City Clerk. I will contact the appointing authority with any questions about my service. **IMPORTANT: Once this form is submitted it becomes a public document, if there is information you do not want open to the public please do not include it on this form!**

SIGNATURE Earle m. Par DATE 4/20/21

Please Return Form To: Mayor@northamptonma.gov or
 David J. Narkewicz, Mayor, 210 Main Street, Northampton, MA 01060



Online Form Submittal: Application for Appointment to Boards, Committees and Commissions

noreply@civicplus.com <noreply@civicplus.com>

Mon, May 3, 2021 at 10:24 AM

To: mayor@northamptonma.gov

Application for Appointment to Boards, Committees and Commissions

City of Northampton Application for Appointment to Boards, Committees, and Commissions

Please return the completed form to: Mayor@northamptonma.gov or David J. Narkewicz, Mayor 210 Main Street, Northampton, MA 01060

First Name	Joseph
Last Name	Blumenthal
Title, if applicable	<i>Field not completed.</i>
Address1	39 Chapel St.
Address2	<i>Field not completed.</i>
City	Northampton
State	MA
Zip	01060
Home Phone	413-586-0492
Work Phone	<i>Field not completed.</i>
Cell Phone	413-210-1654
Occupation & Place of Employment	retired
Email	<i>Field not completed.</i>
Are you a Northampton resident?	Yes
Years Lived in Northampton	47
Age	70 plus

Sex	<i>Field not completed.</i>
Racial / Ethnic Background	<i>Field not completed.</i>
Boards and Committees	Central Business Architecture Committee
Please list "other" board or committee of interest	<i>Field not completed.</i>
What skills and experience will you bring to this committee assignment?	long experience on the board and as owner of commercial real estate
Are you currently serving or have you served on any city committee?	Yes
Please list other city committees you have served on	CBAC

Required: Please read the following, by signing below you state that you understand and agree.

The filing of this form does not guarantee my appointment. An application is kept on file for two (2) years; after that I must file a new application. Being appointed to a committee, board, or commission means that I am considered a Municipal Employee under MGL Chapter 268A and thereby subject to Conflict of Interest Law MGL Chapter 268A, Financial Disclosure Law MGL Chapter 268B, as well as Open Meeting Law MGL Chapter 39: Section 23B. I understand that I will take the conflict of interest test after being appointed and that I also must be sworn in by the City Clerk. I will contact the appointing authority with any questions about my service. Important: Once this form is submitted it becomes a public document, if there is information you do not want open to the public please do not include it on this form.

Signature	Joseph Blumenthal
Date	5/3/2021

Email not displaying correctly? [View it in your browser.](#)



Online Form Submittal: Application for Appointment to Boards, Committees and Commissions

noreply@civicplus.com <noreply@civicplus.com>

Mon, May 3, 2021 at 4:27 PM

To: mayor@northamptonma.gov

Application for Appointment to Boards, Committees and Commissions

City of Northampton Application for Appointment to Boards, Committees, and Commissions

Please return the completed form to: Mayor@northamptonma.gov or David J. Narkewicz, Mayor 210 Main Street, Northampton, MA 01060

First Name	Susan
Last Name	Lofthouse
Title, if applicable	<i>Field not completed.</i>
Address1	15 Stoddard St.
Address2	<i>Field not completed.</i>
City	Northampton
State	MA
Zip	01060
Home Phone	<i>Field not completed.</i>
Work Phone	413-258-8645
Cell Phone	413-588-4083
Occupation & Place of Employment	New England Public Media Mid-Level Giving Manager
Email	slofthouse1@verizon.net
Are you a Northampton resident?	Yes
Years Lived in Northampton	32
Age	50 - 59

Sex	<i>Field not completed.</i>
Racial / Ethnic Background	white
Boards and Committees	Public Shade Tree Commission
Please list "other" board or committee of interest	<i>Field not completed.</i>
What skills and experience will you bring to this committee assignment?	Background in organizing, education, committee work, administration and communications. Founding member Tree Northampton. Experience attending meetings of UFC before and during service. Extensive volunteer participation in tree program.
Are you currently serving or have you served on any city committee?	Yes
Please list other city committees you have served on	Northampton
<p>Required: Please read the following, by signing below you state that you understand and agree.</p> <p><i>The filing of this form does not guarantee my appointment. An application is kept on file for two (2) years; after that I must file a new application. Being appointed to a committee, board, or commission means that I am considered a Municipal Employee under MGL Chapter 268A and thereby subject to Conflict of Interest Law MGL Chapter 268A, Financial Disclosure Law MGL Chapter 268B, as well as Open Meeting Law MGL Chapter 39: Section 23B. I understand that I will take the conflict of interest test after being appointed and that I also must be sworn in by the City Clerk. I will contact the appointing authority with any questions about my service. Important: Once this form is submitted it becomes a public document, if there is information you do not want open to the public please do not include it on this form.</i></p>	
Signature	Susan Lofthouse
Date	5/3/2021

[Quoted text hidden]



Online Form Submittal: Application for Appointment to Boards, Committees and Commissions

noreply@civicplus.com <noreply@civicplus.com>

Sun, Apr 25, 2021 at 6:36 PM

To: mayor@northamptonma.gov

Application for Appointment to Boards, Committees and Commissions

City of Northampton Application for Appointment to Boards, Committees, and Commissions

Please return the completed form to: Mayor@northamptonma.gov or David J. Narkewicz, Mayor 210 Main Street, Northampton, MA 01060

First Name	Robert
Last Name	Dionne
Title, if applicable	<i>Field not completed.</i>
Address1	87 Vernon Street
Address2	<i>Field not completed.</i>
City	NORTHAMPTON
State	MA
Zip	01060
Home Phone	14135844115
Work Phone	<i>Field not completed.</i>
Cell Phone	4133363404
Occupation & Place of Employment	Retired
Email	Parda@comcast.net
Are you a Northampton resident?	Yes
Years Lived in Northampton	50+
Age	70 plus

Sex	Male
Racial / Ethnic Background	Caucasian
Boards and Committees	Council on Aging
Please list "other" board or committee of interest	non at present
What skills and experience will you bring to this committee assignment?	Currently vice chair council on aging
Are you currently serving or have you served on any city committee?	No, Yes
Please list other city committees you have served on	Non at present

Required: Please read the following, by signing below you state that you understand and agree.

The filing of this form does not guarantee my appointment. An application is kept on file for two (2) years; after that I must file a new application. Being appointed to a committee, board, or commission means that I am considered a Municipal Employee under MGL Chapter 268A and thereby subject to Conflict of Interest Law MGL Chapter 268A, Financial Disclosure Law MGL Chapter 268B, as well as Open Meeting Law MGL Chapter 39: Section 23B. I understand that I will take the conflict of interest test after being appointed and that I also must be sworn in by the City Clerk. I will contact the appointing authority with any questions about my service. Important: Once this form is submitted it becomes a public document, if there is information you do not want open to the public please do not include it on this form.

Signature	Robert R. Dionne
Date	4/24/2021

[Quoted text hidden]



Online Form Submittal: Application for Appointment to Boards, Committees and Commissions

1 message

noreply@civicplus.com <noreply@civicplus.com>
To: mayor@northamptonma.gov

Fri, Apr 23, 2021 at 4:50 PM

Application for Appointment to Boards, Committees and Commissions

City of Northampton Application for Appointment to Boards, Committees, and Commissions

Please return the completed form to: Mayor@northamptonma.gov or David J. Narkewicz, Mayor 210 Main Street, Northampton, MA 01060

First Name	Jeanne Henry
Last Name	Hoose
Title, if applicable	<i>Field not completed.</i>
Address1	36 South Park Terrace
Address2	<i>Field not completed.</i>
City	Northampton
State	MA
Zip	01060
Home Phone	4136956438
Work Phone	<i>Field not completed.</i>
Cell Phone	<i>Field not completed.</i>
Occupation & Place of Employment	<i>Field not completed.</i>
Email	jeannehoose@gmail.com
Are you a Northampton resident?	Yes
Years Lived in Northampton	28
Age	60 - 69

Sex	Female
Racial / Ethnic Background	<i>Field not completed.</i>
Boards and Committees	Council on Aging
Please list "other" board or committee of interest	<i>Field not completed.</i>
What skills and experience will you bring to this committee assignment?	Past experience on council, serving as volunteer for senior center
Are you currently serving or have you served on any city committee?	No
Please list other city committees you have served on	Police building and skatepark

Required: Please read the following, by signing below you state that you understand and agree.

The filing of this form does not guarantee my appointment. An application is kept on file for two (2) years; after that I must file a new application. Being appointed to a committee, board, or commission means that I am considered a Municipal Employee under MGL Chapter 268A and thereby subject to Conflict of Interest Law MGL Chapter 268A, Financial Disclosure Law MGL Chapter 268B, as well as Open Meeting Law MGL Chapter 39: Section 23B. I understand that I will take the conflict of interest test after being appointed and that I also must be sworn in by the City Clerk. I will contact the appointing authority with any questions about my service. Important: Once this form is submitted it becomes a public document, if there is information you do not want open to the public please do not include it on this form.

Signature	Jeanne Henry Hoose
Date	4/23/2021

Email not displaying correctly? [View it in your browser.](#)



Online Form Submittal: Application for Appointment to Boards, Committees and Commissions

1 message

noreply@civicplus.com <noreply@civicplus.com>
To: mayor@northamptonma.gov

Fri, Apr 16, 2021 at 9:08 AM

Application for Appointment to Boards, Committees and Commissions

City of Northampton Application for Appointment to Boards, Committees, and Commissions

Please return the completed form to: Mayor@northamptonma.gov or David J. Narkewicz, Mayor 210 Main Street, Northampton, MA 01060

First Name	Dylan
Last Name	Gaffney
Title, if applicable	<i>Field not completed.</i>
Address1	23 Marshall St.
Address2	<i>Field not completed.</i>
City	Northampton
State	MA
Zip	01060
Home Phone	<i>Field not completed.</i>
Work Phone	<i>Field not completed.</i>
Cell Phone	4133205823
Occupation & Place of Employment	Forbes Library
Email	Dgaffney@forbeslibrary.org
Are you a Northampton resident?	Yes
Years Lived in Northampton	51
Age	50 - 59

Sex	Male
Racial / Ethnic Background	<i>Field not completed.</i>
Boards and Committees	Historical Commission
Please list "other" board or committee of interest	<i>Field not completed.</i>
What skills and experience will you bring to this committee assignment?	Years of experience on this board and historical knowledge about the city and its houses.
Are you currently serving or have you served on any city committee?	Yes
Please list other city committees you have served on	Historical Commission, Charter Review Committee
<p>Required: Please read the following, by signing below you state that you understand and agree. <i>The filing of this form does not guarantee my appointment. An application is kept on file for two (2) years; after that I must file a new application. Being appointed to a committee, board, or commission means that I am considered a Municipal Employee under MGL Chapter 268A and thereby subject to Conflict of Interest Law MGL Chapter 268A, Financial Disclosure Law MGL Chapter 268B, as well as Open Meeting Law MGL Chapter 39: Section 23B. I understand that I will take the conflict of interest test after being appointed and that I also must be sworn in by the City Clerk. I will contact the appointing authority with any questions about my service. Important: Once this form is submitted it becomes a public document, if there is information you do not want open to the public please do not include it on this form.</i></p>	
Signature	Dylan Gaffney
Date	4/16/2021

Email not displaying correctly? [View it in your browser.](#)



Online Form Submittal: Application for Appointment to Boards, Committees and Commissions

2 messages

noreply@civicplus.com <noreply@civicplus.com>
To: mayor@northamptonma.gov

Sun, Apr 25, 2021 at 6:03 PM

Application for Appointment to Boards, Committees and Commissions

City of Northampton Application for Appointment to Boards, Committees, and Commissions

Please return the completed form to: Mayor@northamptonma.gov or David J. Narkewicz, Mayor 210 Main Street, Northampton, MA 01060

First Name	Barbara
Last Name	Blumenthal
Title, if applicable	<i>Field not completed.</i>
Address1	39 chapel street
Address2	<i>Field not completed.</i>
City	Northampton
State	Massachusetts
Zip	01060
Home Phone	4135860492
Work Phone	<i>Field not completed.</i>
Cell Phone	4132705464
Occupation & Place of Employment	<i>Field not completed.</i>
Email	bblument@smith.edu
Are you a Northampton resident?	Yes
Years Lived in Northampton	50
Age	60 - 69

Sex	Female
Racial / Ethnic Background	<i>Field not completed.</i>
Boards and Committees	Historical Commission
Please list "other" board or committee of interest	<i>Field not completed.</i>
What skills and experience will you bring to this committee assignment?	Knowledge of local history and experience while serving on NHC and as volunteer and docent at Historic Northampton. I'm requesting reappointment to NHC.
Are you currently serving or have you served on any city committee?	Yes
Please list other city committees you have served on	<i>Field not completed.</i>

Required: Please read the following, by signing below you state that you understand and agree.

The filing of this form does not guarantee my appointment. An application is kept on file for two (2) years; after that I must file a new application. Being appointed to a committee, board, or commission means that I am considered a Municipal Employee under MGL Chapter 268A and thereby subject to Conflict of Interest Law MGL Chapter 268A, Financial Disclosure Law MGL Chapter 268B, as well as Open Meeting Law MGL Chapter 39: Section 23B. I understand that I will take the conflict of interest test after being appointed and that I also must be sworn in by the City Clerk. I will contact the appointing authority with any questions about my service. Important: Once this form is submitted it becomes a public document, if there is information you do not want open to the public please do not include it on this form.

Signature	Barbara Blumenthal
Date	4/25/2021

Email not displaying correctly? [View it in your browser.](#)

noreply@civicplus.com <noreply@civicplus.com>
To: mayor@northamptonma.gov

Sun, Apr 25, 2021 at 6:36 PM

Application for Appointment to Boards, Committees and Commissions

City of Northampton Application for Appointment to Boards, Committees, and Commissions



Online Form Submittal: Application for Appointment to Boards, Committees and Commissions

1 message

noreply@civicplus.com <noreply@civicplus.com>
To: mayor@northamptonma.gov

Mon, May 3, 2021 at 12:28 PM

Application for Appointment to Boards, Committees and Commissions

City of Northampton Application for Appointment to Boards, Committees, and Commissions

Please return the completed form to: Mayor@northamptonma.gov or David J. Narkewicz, Mayor 210 Main Street, Northampton, MA 01060

First Name	Julio
Last Name	Alves
Title, if applicable	<i>Field not completed.</i>
Address1	35 Fort Hill Terrace
Address2	<i>Field not completed.</i>
City	Northampton
State	MA
Zip	01060
Home Phone	<i>Field not completed.</i>
Work Phone	413-585-3033
Cell Phone	413-824-8559
Occupation & Place of Employment	Director, Smith College
Email	jalves750@gmail.com
Are you a Northampton resident?	Yes
Years Lived in Northampton	11
Age	<i>Field not completed.</i>

Sex	<i>Field not completed.</i>
Racial / Ethnic Background	<i>Field not completed.</i>
Boards and Committees	Housing Partnership
Please list "other" board or committee of interest	<i>Field not completed.</i>
What skills and experience will you bring to this committee assignment?	I have been on the Housing Partnership for three years.
Are you currently serving or have you served on any city committee?	Yes
Please list other city committees you have served on	Housing Partnership
<p>Required: Please read the following, by signing below you state that you understand and agree.</p> <p><i>The filing of this form does not guarantee my appointment. An application is kept on file for two (2) years; after that I must file a new application. Being appointed to a committee, board, or commission means that I am considered a Municipal Employee under MGL Chapter 268A and thereby subject to Conflict of Interest Law MGL Chapter 268A, Financial Disclosure Law MGL Chapter 268B, as well as Open Meeting Law MGL Chapter 39: Section 23B. I understand that I will take the conflict of interest test after being appointed and that I also must be sworn in by the City Clerk. I will contact the appointing authority with any questions about my service. Important: Once this form is submitted it becomes a public document, if there is information you do not want open to the public please do not include it on this form.</i></p>	
Signature	Julio Alves
Date	5/3/2021

Email not displaying correctly? [View it in your browser.](#)



Online Form Submittal: Application for Appointment to Boards, Committees and Commissions

noreply@civicplus.com <noreply@civicplus.com>

Mon, May 3, 2021 at 12:39 PM

To: mayor@northamptonma.gov

Application for Appointment to Boards, Committees and Commissions

City of Northampton Application for Appointment to Boards, Committees, and Commissions

Please return the completed form to: Mayor@northamptonma.gov or David J. Narkewicz, Mayor 210 Main Street, Northampton, MA 01060

First Name	James
Last Name	Reis
Title, if applicable	<i>Field not completed.</i>
Address1	108 Coles Meadow Rd.
Address2	<i>Field not completed.</i>
City	Northampton
State	Massachusetts
Zip	01060
Home Phone	413-586-0567
Work Phone	<i>Field not completed.</i>
Cell Phone	413-588-2535
Occupation & Place of Employment	Retired from Way Finders
Email	reis13@comcast.net
Are you a Northampton resident?	Yes
Years Lived in Northampton	42 yrs.
Age	70 plus

Sex	Male
Racial / Ethnic Background	White
Boards and Committees	Housing Partnership
Please list "other" board or committee of interest	<i>Field not completed.</i>
What skills and experience will you bring to this committee assignment?	I retired from Way Finders after 15 yrs as the Associate Ex. Dir., and before that worked at the Franklin/Hampshire Community Mental Health Center in Northampton for 20 yrs. So I have housing development, homelessness, mental health, and community agency experience in Northampton.
Are you currently serving or have you served on any city committee?	Yes
Please list other city committees you have served on	Housing Partnership
<p>Required: Please read the following, by signing below you state that you understand and agree.</p> <p><i>The filing of this form does not guarantee my appointment. An application is kept on file for two (2) years; after that I must file a new application. Being appointed to a committee, board, or commission means that I am considered a Municipal Employee under MGL Chapter 268A and thereby subject to Conflict of Interest Law MGL Chapter 268A, Financial Disclosure Law MGL Chapter 268B, as well as Open Meeting Law MGL Chapter 39: Section 23B. I understand that I will take the conflict of interest test after being appointed and that I also must be sworn in by the City Clerk. I will contact the appointing authority with any questions about my service. Important: Once this form is submitted it becomes a public document, if there is information you do not want open to the public please do not include it on this form.</i></p>	
Signature	James Reis
Date	5/3/2021

[Quoted text hidden]



Online Form Submittal: Application for Appointment to Boards, Committees and Commissions

noreply@civicplus.com <noreply@civicplus.com>

Mon, May 3, 2021 at 1:44 PM

To: mayor@northamptonma.gov

Application for Appointment to Boards, Committees and Commissions

City of Northampton Application for Appointment to Boards, Committees, and Commissions

Please return the completed form to: Mayor@northamptonma.gov or David J. Narkewicz, Mayor 210 Main Street, Northampton, MA 01060

First Name	Julia
Last Name	Chevan
Title, if applicable	Field not completed.
Address1	8 Cosmian Avenue
Address2	Field not completed.
City	Florence
State	MA
Zip	01062
Home Phone	4136877141
Work Phone	4137483590
Cell Phone	4136877141
Occupation & Place of Employment	Professor and Chair, Department of Physical Therapy, Springfield College, Springfield MA
Email	jchevan@comcast.net
Are you a Northampton resident?	Yes
Years Lived in Northampton	31
Age	50 - 59

Sex	Female
Racial / Ethnic Background	<i>Field not completed.</i>
Boards and Committees	Parks and Recreation Commission
Please list "other" board or committee of interest	<i>Field not completed.</i>
What skills and experience will you bring to this committee assignment?	Careful and critical thinking. Knowledge of budgeting process and principles
Are you currently serving or have you served on any city committee?	Yes
Please list other city committees you have served on	Parks and Recreation, Community Preservation Committee

Required: Please read the following, by signing below you state that you understand and agree.

The filing of this form does not guarantee my appointment. An application is kept on file for two (2) years; after that I must file a new application. Being appointed to a committee, board, or commission means that I am considered a Municipal Employee under MGL Chapter 268A and thereby subject to Conflict of Interest Law MGL Chapter 268A, Financial Disclosure Law MGL Chapter 268B, as well as Open Meeting Law MGL Chapter 39: Section 23B. I understand that I will take the conflict of interest test after being appointed and that I also must be sworn in by the City Clerk. I will contact the appointing authority with any questions about my service. Important: Once this form is submitted it becomes a public document, if there is information you do not want open to the public please do not include it on this form.

Signature	Julia Chevan
Date	5/3/2021

[Quoted text hidden]



Online Form Submittal: Application for Appointment to Boards, Committees and Commissions

noreply@civicplus.com <noreply@civicplus.com>

Mon, May 3, 2021 at 2:44 PM

To: mayor@northamptonma.gov

Application for Appointment to Boards, Committees and Commissions

City of Northampton Application for Appointment to Boards, Committees, and Commissions

Please return the completed form to: Mayor@northamptonma.gov or David J. Narkewicz, Mayor 210 Main Street, Northampton, MA 01060

First Name	George
Last Name	Kohout
Title, if applicable	<i>Field not completed.</i>
Address1	234 State St
Address2	<i>Field not completed.</i>
City	N'ton
State	MA
Zip	01060
Home Phone	<i>Field not completed.</i>
Work Phone	<i>Field not completed.</i>
Cell Phone	413 320 2226
Occupation & Place of Employment	retired
Email	geokohout@gmail.com
Are you a Northampton resident?	Yes
Years Lived in Northampton	35
Age	60 - 69

Sex	Male
Racial / Ethnic Background	White
Boards and Committees	Planning Board
Please list "other" board or committee of interest	<i>Field not completed.</i>
What skills and experience will you bring to this committee assignment?	I Served on the Planning Board from 2000 - 2009, took a few years off and was reappointed to the Board in July 2018. This application is for a reappointment to the Board
Are you currently serving or have you served on any city committee?	Yes
Please list other city committees you have served on	Community Preservation Committee, Capital Improvements Program
<p>Required: Please read the following, by signing below you state that you understand and agree.</p> <p><i>The filing of this form does not guarantee my appointment. An application is kept on file for two (2) years; after that I must file a new application. Being appointed to a committee, board, or commission means that I am considered a Municipal Employee under MGL Chapter 268A and thereby subject to Conflict of Interest Law MGL Chapter 268A, Financial Disclosure Law MGL Chapter 268B, as well as Open Meeting Law MGL Chapter 39: Section 23B. I understand that I will take the conflict of interest test after being appointed and that I also must be sworn in by the City Clerk. I will contact the appointing authority with any questions about my service. Important: Once this form is submitted it becomes a public document, if there is information you do not want open to the public please do not include it on this form.</i></p>	
Signature	George Kohout
Date	5/3/2021

[Quoted text hidden]



Online Form Submittal: Application for Appointment to Boards, Committees and Commissions

noreply@civicplus.com <noreply@civicplus.com>

Tue, May 4, 2021 at 9:24 AM

To: mayor@northamptonma.gov

Application for Appointment to Boards, Committees and Commissions

City of Northampton Application for Appointment to Boards, Committees, and Commissions

Please return the completed form to: Mayor@northamptonma.gov or David J. Narkewicz, Mayor 210 Main Street, Northampton, MA 01060

First Name	Maureen
Last Name	Scanlon
Title, if applicable	Field not completed.
Address1	197 NONOTUCK ST
Address2	Field not completed.
City	FLORENCE
State	MA
Zip	01062-1907
Home Phone	4135888071
Work Phone	Field not completed.
Cell Phone	Field not completed.
Occupation & Place of Employment	Self employed graphic designer: Sole proprietor, Murre Creative, 221 Pine Street, Florence
Email	maureen@maureenscanlon.com
Are you a Northampton resident?	Yes
Years Lived in Northampton	40
Age	60 - 69

Sex	Female
Racial / Ethnic Background	White
Boards and Committees	Zoning Board of Appeals
Please list "other" board or committee of interest	<i>Field not completed.</i>
What skills and experience will you bring to this committee assignment?	Served one term on ZBA to date. Previous relevant experience: Served on the Design Review Committee for the city of Winooski, VT before moving to Northampton in 1981
Are you currently serving or have you served on any city committee?	Yes
Please list other city committees you have served on	ZBA as noted above

Required: Please read the following, by signing below you state that you understand and agree.

The filing of this form does not guarantee my appointment. An application is kept on file for two (2) years; after that I must file a new application. Being appointed to a committee, board, or commission means that I am considered a Municipal Employee under MGL Chapter 268A and thereby subject to Conflict of Interest Law MGL Chapter 268A, Financial Disclosure Law MGL Chapter 268B, as well as Open Meeting Law MGL Chapter 39: Section 23B. I understand that I will take the conflict of interest test after being appointed and that I also must be sworn in by the City Clerk. I will contact the appointing authority with any questions about my service. Important: Once this form is submitted it becomes a public document, if there is information you do not want open to the public please do not include it on this form.

Signature	Maureen Scanlon
Date	5/4/2021

Email not displaying correctly? [View it in your browser.](#)

City of Northampton
MASSACHUSETTS

In City Council

May 6, 2021

Upon recommendation of the Mayor

21.264 An Order for FY2021 Budget Transfers

Ordered, that

The following budgetary transfers be made:

Department		Description	Org	Object	Transfer From:	Transfer To:
DPW Forestry, Parks and Cemeteries	PS	Permanent Salaries	14921	511000	\$ (40,000)	
DPW Forestry, Parks and Cemeteries	OOM	Grounds Equipment	14923	571001		\$ 40,000
Fire Rescue	PS	Permanent Salaries	12201	511000	\$ (46,000)	
Fire Rescue	OM	Equipment Replacement	12202	587000		\$ 46,000
Employee Benefits	PS	Medical Insurance	19141	519400	\$(132,456)	
Other Employee Benefits	PS	Medicare	19191	517001	\$ (26,588)	
Unemployment	PS	Unemployment Compensation	19131	519300	\$ (23,668)	
Health	PS	Salaries Permanent	15111	511000	\$ (29,744)	
Assessors	PS	Permanent Salaries	11411	511000	\$ (8,004)	
Mayor	PS	Overtime	11211	513000		\$ 1,475
Mayor	PS	Permanent Salaries	11211	511000		\$ 14,000
Planning and Sustainability	PS	Overtime	11751	513000		\$ 7,995
Building Inspections	PS	Overtime	12411	513000		\$ 13,750
Building Inspections	PS	Salaries Tech/Prof	12411	512000		\$ 16,997
DPW Administration	PS	Permanent Salaries	14211	511000		\$ 3,608
DPW Snow and Ice	PS	Overtime	14231	513000		\$ 45,651
DPW Snow and Ice	OM	Vehicular Supplies	14232	548000		\$ 37,553
DPW Snow and Ice	OM	Snow Removal Supplies	14232	553020		\$ 79,431
Assessors	PS	Permanent Salaries	11411	511000	\$ (26,500)	
Assessors	OM	Property Revaluation Services	11412	530014		\$ 26,500
Total Budgetary Transfers:					\$(332,960)	\$ 332,960

City of Northampton

MASSACHUSETTS

In City Council, May 6, 2021

Upon the recommendation of Mayor David J. Narkewicz

**O-21.265 AN ORDER AUTHORIZING ACQUISITION AND
ESTABLISHMENT OF A MUNICIPAL LIGHT PLANT**

WHEREAS, the Mayor and City Council approved a two-phase market study and comprehensive feasibility study of municipal broadband as part of the FY2020-FY2024 Capital Improvement Program; and

WHEREAS, the City of Northampton awarded a contract for the aforementioned two-phase study to Design Nine, Inc. which has completed a market study, the overwhelmingly positive results of which dictate moving forward with the comprehensive feasibility study; and

WHEREAS, if based on the results of both studies the City of Northampton decides to implement municipal broadband, the city would be required to establish a Municipal Light Plant in accordance with M.G.L. c. 164, § 35; and

WHEREAS, establishment of a Municipal Light Plan under section 35 first requires two separate approval votes of the City Council by a two-thirds majority in two separate fiscal years; and

WHEREAS, the City Council approved the establishment of a Municipal Light Plan in fiscal year 2020 on June 18, 2020; and

WHEREAS, in the interest of not unnecessarily delaying a future potential municipal broadband project, it would be prudent to complete the second required approval vote in fiscal year 2021 ending June 30, 2021.

NOW, THEREFORE, be it ordered, the City Council authorizes in accordance with the provisions of Chapter 164 of the General Laws and in accordance with the rules, regulations and orders of the Department of Public Utilities and the Department of Telecommunications & Cable, a municipal lighting plant for all purposes allowable under the laws of the Commonwealth, and more particularly for the establishment a municipal broadband system for the City of Northampton. The Mayor is hereby authorized to execute any documents necessary to effectuate this Order.

City of Northampton

MASSACHUSETTS

In City Council, April 15, 2021

Upon the recommendation of Mayor David J. Narkewicz, Conservation Commission and Planning & Sustainability

21.244 An Order to Acquire and Amend Easements at the Mill River Greenway-Smith College

Ordered, that

WHEREAS, The ***Open Space and Recreation Plan: 2018-2025*** recommends expanding public access along the Mill River as part of the ***Mill River Greenway*** and the ***Climate Resilience and Regeneration Plan (2021)*** recommends moving to renewable energy and electrification of thermal loads;

WHEREAS, The Trustees of the Smith College granted the City an ***Open Space Restriction and Public Right of Way Easement*** recorded at Hampshire Registry of Deeds at Book 5900, Page 26 (3/14/2000) and Book 5898, Page 39 (3/9/2000);

WHEREAS, The City of Northampton would like to revise this restriction to be a formal conservation restriction in accordance with MGL Chapter 184, Section 31;

WHEREAS, Smith College would reserve the right to use area within 200 feet of the gravel road shown on a plan entitled "*Boundary Survey of Land of the Commonwealth of Massachusetts, formerly the Northampton State Hospital, Northampton, Massachusetts*" dated December 17, 1996 and recorded at Hampshire Registry of Deeds (Plan Book 183, Page 3, Sheet 3) for any parking uses. This area is currently allowed for parking for recreation uses and expanding to non-recreation uses will have no adverse impact on the conservation values;

WHEREAS, Smith College would reserve the right for underground piping and heat exchange for ground sourced heat pumps on the premises so that, other than during construction, reconstruction, and repair activities, the facilities will not be visible above grade. This use is consistent with the City's *Climate Resilience and Regeneration Plan* and will have no adverse impact on conservation values;

WHEREAS, Smith College is prepared to simultaneously expand the existing easement "to allow the public to pass and repass on foot trails for the purpose of fishing, hiking, winter sports..." to include all trails within 100 feet of the Mill River, on the northeasterly side of the Mill River, northerly and westerly of the Smith College crew house, and westerly of College Lane on the Smith College campus;

WHEREAS, The amendments of the open space restriction requires approval of the Massachusetts General Court under Article 97 of the Amendments to the State Constitution.

Ordered, that

The Mayor and the Conservation Commission is authorized to amend the existing ***Open Space Restriction and Public Right of Way Easement*** to expand the uses of existing parking areas, allow underground piping for ground source heat pumps, and accept the new expanded easement;

Further, the City requests and petitions that our legislative delegation file legislation substantially as follows:

An Act authorizing the City of Northampton to amend a certain conservation easement.

Be it enacted by the Senate and House of Representatives in General Court assembled, and by the authority of the same as follows:

SECTION 1. Notwithstanding any general or special law to the contrary, the city of Northampton, acting by and through its mayor and conservation commission, may amend the Open Space Restriction and Public Right of Way Easement recorded at Hampshire Registry of Deeds at Book 5900, Page 26 and Book 5898, Page 39 to allow any parking within 200 feet of the gravel road shown on a plan entitled "Boundary Survey of Land of the Commonwealth of Massachusetts, formerly the Northampton State Hospital, Northampton, Massachusetts" dated December 17, 1996 and recorded at Hampshire Registry of Deeds at Plan Book 183, Page 3, Sheet 3 and allow underground piping and heat exchange for ground source heat pumps and to record the new restriction as a conservation restriction under the authority of MGL Chapter 184, Section 31.

SECTION 2. As a condition and in consideration for the amendment to the easement as provided in section 1 of this act, and at the same time as such release, the city of Northampton, acting by and through its conservation commission, shall accept an expanded public right-of-way easement to allow the public to pass and repass on foot trails for the purpose of fishing, hiking, winter sports on all trails within 100 feet of the Mill River on the northerly side of the river, northerly and westerly of the Smith College crew house, and westerly of College Lane on the Smith College campus, Northampton.

City of Northampton
MASSACHUSETTS

In City Council, April 15, 2021

Upon the recommendation of the Community Preservation Committee
21.248 An Order to Appropriate CPA Funds for Historic Northampton Collections Storage

Ordered, that

WHEREAS, Historic Northampton, Inc. submitted a Small Grants application for Community Preservation Act funding to purchase appropriate collections storage for its ephemera, photograph and research collections;

WHEREAS, the collections yield important information about Northampton's history, and are frequently accessed for research by community members, businesses, and nonprofits;

WHEREAS, improved collections storage was a critical recommendation of the Massachusetts State Historic Records Board, and will protect these resources for the future;

WHEREAS, on February 17, 2021 the Northampton Community Preservation Committee, voted unanimously to recommend that \$3,000 in Community Preservation Act funds be used to support this project.

NOW, THEREFORE BE IT ORDERED,

That \$3,000 be appropriated from Community Preservation Act funding to Historic Northampton, Inc. for purchase and installation of new collections storage. And, that the grantee meets the conditions approved by the Community Preservation Committee, the Mayor, and City Council.

Specifically, \$3,000 is appropriated from the CPA Historic Preservation Reserve (account #2344930-359932).

City of Northampton

MASSACHUSETTS

In City Council, April 15, 2021

Upon the recommendation of the Community Preservation Committee

21.249 An Order to Appropriate \$120,000 in CPA Funds Toward Habitat Housing on Burts Pit Road

Ordered, that

WHEREAS, Pioneer Valley Habitat for Humanity submitted an application for Community Preservation Act funding for creation of three energy efficient affordable homes on Burts Pit Road;

WHEREAS, Habitat for Humanity has an excellent record of creating housing throughout the Pioneer Valley and beyond;

WHEREAS, the project has wide community support, leverages funding from many other sources, and utilizes volunteer labor;

WHEREAS, the homes will be permanently restricted to individuals and families earning 60% of area median income or below;

WHEREAS, on April 7, 2021, the Northampton Community Preservation Committee voted unanimously to recommend that \$120,000 in Community Preservation Act funds be used to support this project.

NOW, THEREFORE BE IT ORDERED,

That \$120,000 be appropriated from Community Preservation Act funding to Pioneer Valley Habitat for Humanity for the Broughton's Meadow Small Home Project. And, that the grantee meets the conditions approved by the Community Preservation Committee, the Mayor, and City Council.

Specifically, \$39,525 is appropriated from the CPA Budgeted Reserve (account #2344930-359930, and is \$80,475 allocated from the CPA Affordable Housing Reserve (account #2344930-359933)

City of Northampton
MASSACHUSETTS

In City Council, April 15, 2021

Upon the recommendation of the Community Preservation Committee

21.250 An Order to Appropriate \$14,500 in CPA Funds to Lilly Library Stair Repair Project

Ordered, that

WHEREAS, Lilly Library. submitted a CPA application for Community Preservation Act funding to conduct critical structural repairs to the historic entrance to the Library;

WHEREAS, all work will be consistent with the Secretary of the Interior Standards for the Treatment of Historic Properties;

WHEREAS, Lilly Library is an institution that has been an essential component of the Florence community for over 130 years, and this project will maintain the historic nature while ensuring continued functionality of the building;

WHEREAS, on April 7, 2021 the Northampton Community Preservation Committee, voted unanimously to recommend that \$14,500 in Community Preservation Act funds be used to support this project.

NOW, THEREFORE BE IT ORDERED,

That \$14,500 be appropriated from Community Preservation Act funding to Lilly Library for the Stair Repair project. And, that the grantee meets the conditions approved by the Community Preservation Committee, the Mayor, and City Council. Specifically, \$14,500 is appropriated from the CPA Historic Preservation Reserve (account #2344930-359932).

City of Northampton
MASSACHUSETTS

In City Council, April 15, 2021

Upon the recommendation of the Community Preservation Committee
21.251 An Order to Appropriate \$70,000 in CPA Funds for Historic Preservation Plan

Ordered, that

WHEREAS, the Office of Planning and Sustainability submitted an application for Community Preservation Act funding for creation of a Historic Preservation Plan to identify historic and cultural resources, assess current status, recognize issues and opportunities to help ensure that those resources are protected;

WHEREAS, through a collaborative community process and analysis of resource data and community values, the Plan will develop a vision, goal, priorities, and toolbox for preservation of priority historic and cultural resources and will become a component of the City's Sustainable Northampton Comprehensive Plan;

WHEREAS, on April 7, 2021, the Northampton Community Preservation Committee, voted unanimously to recommend that \$70,000 in Community Preservation Act funds be used to support this project.

NOW, THEREFORE BE IT ORDERED,

That \$70,000 be appropriated from Community Preservation Act funding to the Historic Preservation Plan. And, that the grantee meets the conditions approved by the Community Preservation Committee, the Mayor, and City Council.

Specifically, \$5,891 is allocated from the CPA Historic Preservation Reserve (account #2344930-359932), and \$64,109 is allocated from the CPA Budgeted Reserve (account #2344930-359930).

City of Northampton
MASSACHUSETTS

In City Council, April 15, 2021

Upon the recommendation of the Community Preservation Committee
21.252 An Order to Appropriate \$21,250 for Damon House/Shepherd Barn Project

Ordered, that

WHEREAS, Historic Northampton, Inc. submitted a CPA application for Community Preservation Act funding for restoration of the Damon House roofline balustrade, and for a structural analysis of the Shepherd Barn;

WHEREAS, all work will be consistent with the Secretary of the Interior's Standards for the Treatment of Historic Properties;

WHEREAS, CPA funds will be used to help secure an important historic resource that is valued by the community and the region, on which the City holds a permanent preservation restriction, and will expand Historic Northampton's public programming opportunities;

WHEREAS, on April 7, 2021 the Northampton Community Preservation Committee, voted unanimously to recommend that \$21,250 in Community Preservation Act funds be used to support this project.

NOW, THEREFORE BE IT ORDERED,

That \$21,250 be appropriated from Community Preservation Act funding to Historic Northampton, Inc. for the Shepherd/Damon project. And, that the grantee meets the conditions approved by the Community Preservation Committee, the Mayor, and City Council.

Specifically, \$21,250 is appropriated from the CPA Historic Preservation Reserve (account #2344930-359932).

City of Northampton
MASSACHUSETTS

In City Council, April 15, 2021

Upon the recommendation of the Community Preservation Committee

21.253 An Order to Appropriate \$60,000 in CPA Funds for Mill River Greenway Beach Project

Ordered, that

WHEREAS, the Northampton Conservation Commission and Office of Planning & Sustainability submitted a CPA application to acquire a 3.3 acre parcel along the Mill River in Leeds abutting the existing Mill River Greenway which includes recreational opportunities for all seasons;

WHEREAS, subject to the City successfully negotiating a conservation restriction which contains an adequate private party maintenance agreement;

WHEREAS, the project meets the goals of the Sustainable Northampton Plan, Northampton Community Preservation Plan, and Open Space, Recreation and Multi-use Trail Plan to protect open space, and provide recreational opportunities;

WHEREAS, on April 7, 2021, the Northampton Community Preservation Committee voted unanimously to recommend that \$60,000 in Community Preservation Act funds be used to support this project.

NOW, THEREFORE BE IT ORDERED,

That \$60,000 be appropriated from Community Preservation Act funding to the Northampton Conservation Commission and Office of Planning and Sustainability for the Mill River Greenway Beach acquisition Project. And, that the grantee meets the conditions approved by the Community Preservation Committee, the Mayor, and City Council.

Specifically, \$60,000 is appropriated from the CPA Budgeted Reserve (account #2344930-359930).

City of Northampton
MASSACHUSETTS

In City Council, April 15, 2021

Upon the recommendation of the Community Preservation Committee
21.254 An Order to Appropriate \$50,000 in CPA Funds to the Affordable Housing Fund

Ordered, that

WHEREAS, the Office of Planning and Sustainability submitted an application for Community Preservation Act funding for the Affordable Housing Fund;

WHEREAS, the fund will be used for due diligence and soft costs for predevelopment work necessary for new affordable housing opportunities that the City creates, and for which no other funds are readily available, and will help to leverage future funding opportunities from other sources;

WHEREAS, this fund will result in new affordable housing opportunities in Northampton, meets the goals of the Housing Needs Assessment and Strategic Plan, and will help to address impediments to fair housing identified in the Fair Housing Assessment;

WHEREAS, on April 7, 2021, the Northampton Community Preservation Committee, voted unanimously to recommend that \$50,000 in Community Preservation Act funds be used to support this project.

NOW, THEREFORE BE IT ORDERED,

That \$50,000 be appropriated from Community Preservation Act funding to the Affordable Housing Fund. And, that the grantee meets the conditions approved by the Community Preservation Committee, the Mayor, and City Council.

Specifically, \$50,000 is allocated from the CPA Affordable Housing Reserve (account #2344930-359933)

City of Northampton

MASSACHUSETTS

In City Council, April 15, 2021

Upon the recommendation of Mayor David J. Narkewicz and Department of Planning and Sustainability

**21.255 AN ORDER AUTHORIZING ACQUISITION OF A PARCEL OF LAND
ON THE SOUTHEASTERLY SIDE OF BRIERWOOD DRIVE**

WHEREAS, the parcel subject to this Order is located on the southeasterly side of Brierwood Drive and is shown on a plan of land entitled "Plan of Lots in Northampton, Mass. Owned by Edbert Homes, Inc.," dated July 12, 1965, and recorded in Hampshire Registry of Deeds in Plan Book 67, Pages 94-95, ("the Plan") being the southernly one-third of lot 31-A on the Plan ("the Parcel"); and

WHEREAS, the Parcel excludes that portion of lot 31-A that is shown on the plan entitled "Plan of Lots in Northampton, Mass. Owned by Edbert Homes, Inc.," dated April 1964, and recorded in the Hampshire Registry of Deeds in Plan Book 65, Page 56A, also shown thereon as lot 31-A; and

WHEREAS, the Parcel abuts the property of the R.K. Finn Ryan Road Elementary School; and

WHEREAS, the owner of the Parcel, Edbert Homes, Inc., was involuntarily dissolved by order of the Secretary of the Commonwealth in 1979; and

WHEREAS, the Parcel is subject to an existing tax lien for unpaid taxes that exceed the value of the Parcel; and

WHEREAS, the Parcel contains the layout of a City sewer line; and

WHEREAS, the Parcel would enhance access to the abutting school property from the neighborhood shown on the Plan.

NOW, THEREFORE BE IT ORDERED,

The City Council hereby authorizes the acquisition by purchase, gift, eminent domain, or otherwise of the Parcel described above for access to and egress from the land of the R.K. Finn Ryan Road Elementary School.

As damages for the taking, the City Council hereby awards Three Thousand One Hundred Dollars (\$3,100.00) which shall be applied to the outstanding balance on taxes due and owing on the Parcel.

**Property Address:
Southeasterly Side of Brierwood Drive
Florence, MA**

ORDER OF TAKING

The undersigned, being the duly elected and sitting members of the City Council of the City of Northampton, in the Commonwealth of Massachusetts, acting under the authority of and in accordance with the provisions of General Laws of the Commonwealth, as from time to time amended, and more particularly Chapter 79, and pursuant to the Order of the Northampton City Council, a true copy of which is attached hereto as Exhibit A, does hereby take the parcel of land herein described in fee simple absolute for access to the R.K. Finn Ryan Road School.

The land taken herein is shown as Lot 31-A on a plan of land recorded in the Hampshire Registry of Deeds, Plan Book 67, Page 94, but specifically excepting and excluding the parcel of land shown as Lot 31-A on a plan recorded in Plan Book 65, Page 56A and also described in a deed recorded in Book 1486, Page 148.”

As pro tanto damages for the taking herein, the City of Northampton awards the sum of \$3,100.00, which shall be applied to reduce or release the tax lien encumbering such parcel.

For title see deed of Martin J. Beattie and Catherine C. Beattie to Edbert Homes, Inc., dated September 30, 1959, and recorded in the Hampshire Registry of Deeds Book 1312, Page 353.

[SIGNATURE PAGES FOLLOW]

IN WITNESS WHEREOF, We, the City Council of the City of Northampton, have executed this Order of Taking this ____ day of _____, 2021.

WITNESS TO ALL:

CITY COUNCIL, CITY OF NORTHAMPTON, MA

Gina-Louise Sciarra
AT-LARGE COUNCILOR

William H. Dwight
AT-LARGE COUNCILOR

Michael Quinlan, Jr.
WARD 1 COUNCILOR

Karen Foster
WARD 2 COUNCILOR

James Nash
WARD 3 COUNCILOR

John Thorpe
WARD 4 COUNCILOR

Alex Jarrett
WARD 5 COUNCILOR

Marianne L. LaBarge
WARD 6 COUNCILOR

Rachel Maiore
WARD 7 COUNCILOR

CERTIFICATE OF THE CLERK
CITY COUNCIL, CITY OF NORTHAMPTON, MA

I, Laura Krutzler, the Clerk of the City Council of the City of Northampton, MA, hereby certify that the attached Order of Taking of a certain parcel of land located in Northampton, Hampshire County, Massachusetts, was executed on _____, 2021, by Gina-Louise Sciarra, William H. Dwight, Michael Quinlan, Jr., Karen Foster, James Nash, John Thorpe, Alex Jarrett, Marianne L. LaBarge, and Rachel Maoire, who as of that day, were and are the duly elected members of the City Council of the City of Northampton, MA.

Signed this ____ day of _____, 2021.

Laura Krutzler
Clerk to City Council
City of Northampton, Massachusetts

EXHIBIT A
CITY COUNCIL ORDER

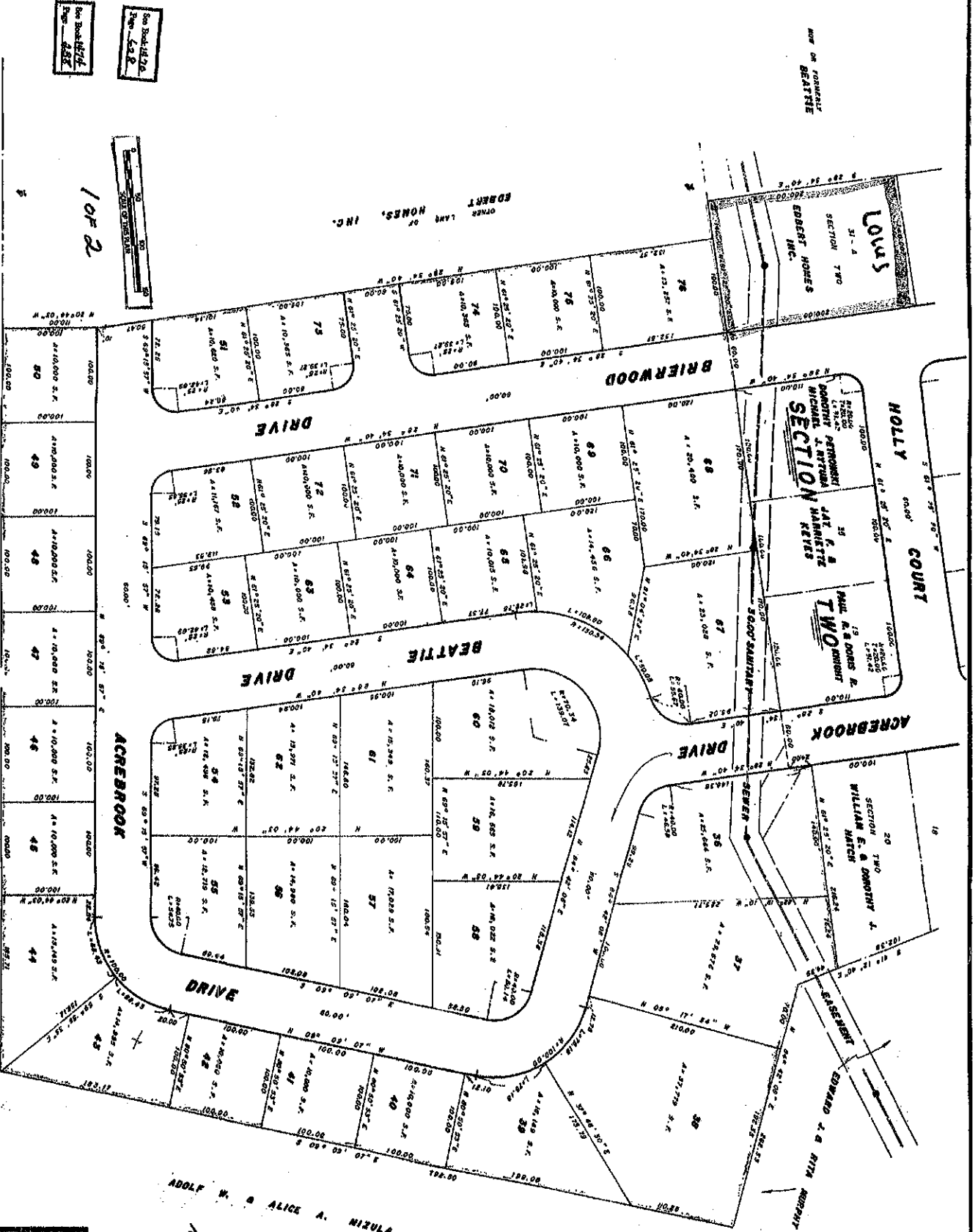

See Book 67 of
Plat 488

See Book 67 of
Plat 488

1 of 2

Robert Lamm
of
Robert Homes, Inc.

Holly Court

SECTION

ADOLF W. & ALICE A. MIZULA
368-154

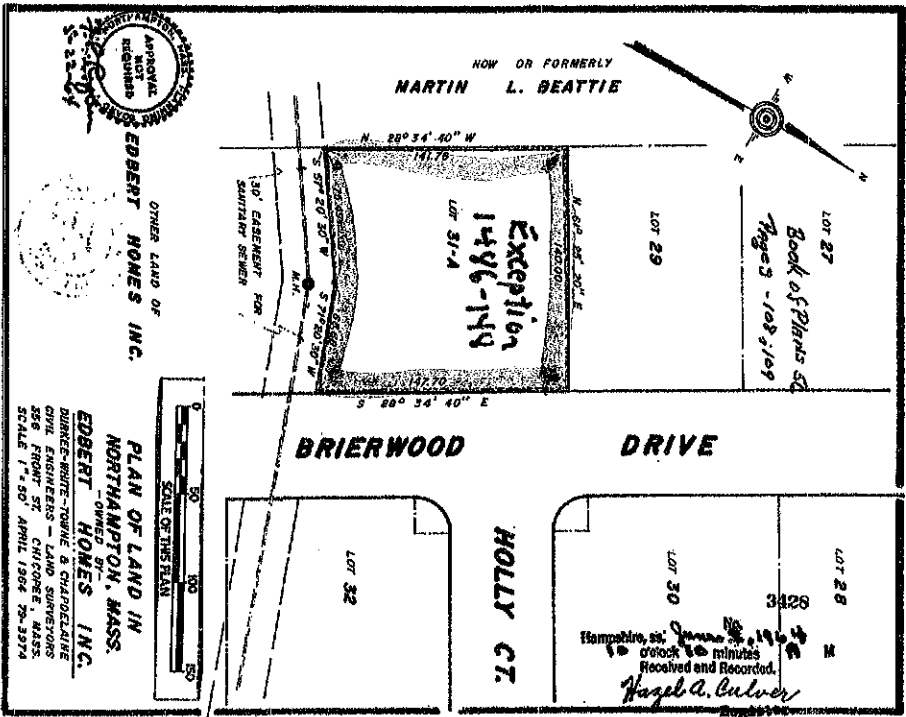

NOTICE OF NONEXERCISE
City of Northampton Right Refusal/Option
G.L. c. 61A

OWNER: Robert A. Borawski and Ann M. Borawski
17 Audubon Road, Northampton, MA 01060
Book 7156, Page 275

Premises: Parcel A, **Plan Book 248, Page 90**
2.93 Acres +/-, off Kennedy Road

The City of Northampton hereby affirms that it has elected not to exercise its right of refusal/option to purchase the above referenced parcel after receipt of Notice of Sale from the above referenced Owner, in compliance with G.L. c. 61A, and release its lien and option to purchase from the lien in **Book 2413, Page 775**.

City of Northampton

Witness

By: _____
David Narkewicz, Mayor

Approved:

Alan Seewald, City Solicitor

COMMONWEALTH OF MASSACHUSETTS

County of Hampshire

On this ____ day of _____, 2021, before me, the undersigned notary public, personally appeared David Narkewicz, and proved to me through satisfactory evidence of identification, which was personal knowledge, to be the person whose name is signed on the preceding or attached document, and acknowledged to me that he signed it voluntarily for its stated purpose as the mayor of The City of Northampton as the voluntary act of such entity.

Notary Public
My Commission Expires:

**CITY OF NORTHAMPTON
MASSACHUSETTS**

In the Year Two Thousand and Twenty-One

Upon the Recommendation of the Transportation and Parking Commission

**21.198
AN ORDINANCE**

**RELATIVE TO A STOP SIGN ON
SCANLON AVENUE**

An Ordinance of the City of Northampton, Massachusetts. Be it ordained by the City Council of the City of Northampton, in City Council assembled, as follows:

SECTION 1

That the § 312-113 of the Code of Ordinances be amended as follows:

§ 312-113 Schedule XII: Stop and Yield Intersections.

Location	Direction of Travel	At the Intersection of
<u>Scanlon Avenue</u>	<u>West</u>	<u>Florence Road</u>

**CITY OF NORTHAMPTON
MASSACHUSETTS**

In the Year Two Thousand and Twenty-One

Upon the Recommendation of the Transportation and Parking Commission

**21.199
AN ORDINANCE**

**RELATIVE TO STOP SIGNS ON
CROSS STREET**

An Ordinance of the City of Northampton, Massachusetts. Be it ordained by the City Council of the City of Northampton, in City Council assembled, as follows:

SECTION 1

That the § 312-113 of the Code of Ordinances be amended as follows:

§ 312-113 Schedule XII: Stop and Yield Intersections.

Location	Direction of Travel	At the Intersection of
<u>Cross Street</u>	<u>West</u>	<u>Florence Road</u>
<u>Cross Street</u>	<u>East</u>	<u>Bliss Street</u>

**CITY OF NORTHAMPTON
MASSACHUSETTS**

In the Year Two Thousand and Twenty-One

Upon the Recommendation of Mayor David J. Narkewicz and the Department of Public Works

**21.213
AN ORDINANCE**

**RELATIVE TO PARKING ON
PINE STREET**

An Ordinance of the City of Northampton, Massachusetts. Be it ordained by the City Council of the City of Northampton, in City Council assembled, as follows:

SECTION 1

That the § 312-102 of the Code of Ordinances be amended as follows:

§ 312-102 Schedule I: Parking Prohibited All Times.

Location	Side	From	To
Pine Street [Added 8-15-1985]	North-westerly	Chestnut Street	Point 210 feet north-westerly from Chestnut Street South Main Street

**CITY OF NORTHAMPTON
MASSACHUSETTS**

In the Year Two Thousand and Twenty-One

Upon the Recommendation of Mayor David J. Narkewicz and the Department of Public Works

**21.214
AN ORDINANCE**

**RELATIVE TO STOP SIGNS ON
MAPLE STREET, MANN TERRACE, AND PINE STREET**

An Ordinance of the City of Northampton, Massachusetts. Be it ordained by the City Council of the City of Northampton, in City Council assembled, as follows:

SECTION 1

That the § 312-113 of the Code of Ordinances be amended as follows:

§ 312-113 Schedule XII: Stop and Yield Intersections.

A. Isolated stop signs. Stop intersections are established at the following locations:

Location	Direction of Travel	At the Intersection of
Pine Street	East	Maple Street
Pine Street	West	Maple Street
<u>Mann Terrace</u>	<u>North</u>	<u>Pine Street</u>

D. Multiway stop signs. Multiway stop intersections are established at the following locations:

Name of Street	Direction of Travel	Intersection
<u>Pine Street</u>	<u>East/West</u>	<u>Maple Street</u>
<u>Maple Street</u>	<u>North/South</u>	<u>Pine Street</u>

**CITY OF NORTHAMPTON
MASSACHUSETTS**

In the Year Two Thousand and Twenty-One

Upon the Recommendation of Mayor David J. Narkewicz and the Department of Public Works

**21.215
AN ORDINANCE**

**RELATIVE TO TURNING RESTRICTION ON
MANN TERRACE**

An Ordinance of the City of Northampton, Massachusetts. Be it ordained by the City Council of the City of Northampton, in City Council assembled, as follows:

SECTION 1

That the § 312-115 of the Code of Ordinances be amended as follows:

§ 312-115 Schedule XIV: Left Turns Prohibited.

Name of Street	Direction of Travel	Left Turn Prohibited Onto
<u>Mann Terrace</u>	<u>North</u>	<u>Pine Street</u>

**CITY OF NORTHAMPTON
MASSACHUSETTS**

In the Year Two Thousand and Twenty-One

Upon the Recommendation of Mayor David J. Narkewicz and the Department of Public Works

**21.216
AN ORDINANCE**

**RELATIVE TO ONE-WAY STREET ON
MANN TERRACE**

An Ordinance of the City of Northampton, Massachusetts. Be it ordained by the City Council of the City of Northampton, in City Council assembled, as follows:

SECTION 1

That the § 312-112 of the Code of Ordinances be amended as follows:

§ 312-112 Schedule XI: One-Way Streets.

Location	Direction	From	To
Mann Terrace	Northwesterly	A point 60 feet southeasterly of Pine Street	Pine Street