

CITY COUNCIL
CITY OF NORTHAMPTON
MASSACHUSETTS

Councilors:

- President Gina-Louise Sciarra, At-Large
- William H. Dwight, At-Large
- Michael J. Quinlan, Jr., Ward 1
- Karen Foster, Ward 2
- Vice-President James Nash, Ward 3
- John Thorpe, Ward 4
- Alex Jarrett, Ward 5
- Marianne L. LaBarge, Ward 6
- Rachel Maiore, Ward 7

Meeting Agenda
On-line Video Conference
Meeting Date: May 6, 2021
Meeting Time: 7 p.m.

The May 6, 2021 City Council meeting will be held by remote participation. The public can follow the council's deliberations by watching the meeting live on Comcast channel 15, live-streaming it on YouTube or joining the virtual meeting by phone or computer. For the active YouTube link, please see Northampton Open Media's website: <http://northamptonopenmedia.org/>

Live public comment will be available using telephone call-in or video conferencing technology beginning at 7 p.m.

INSTRUCTIONS FOR CALLING IN OR JOINING THE MEETING

Join meeting: <https://bit.ly/3sUdjUe>

For telephone call-in, call:

+253 215-8785 US

+301 715-8592 US

MEETING ID: 934 2443 0260

PARTICIPANT #: #

PASSCODE: 585930

1. Announcement that Meeting is Being Held Via Remote Participation and Audio/Video Recorded

This meeting is being held via remote participation and audio/video recorded.

2. Public Comment

3. Roll Call

4. Public Hearings

A. 7:05 pm **Public Hearing on 21.197 National Grid/Verizon Petition for Installation of Underground Conduit on Damon Road (Petition#23303524)**

Per M.G.L. Ch. 166, Section 22, the Northampton City Council will hold a public hearing on **Thursday, May 6, 2021 at 7:05 p.m.** on National Grid/Verizon New England's petition to install underground conduit on Damon Road (Petition #23303524). The City Council will hear all persons who wish to be heard thereon.

Documents:

[21.197 DPW Recommendation.pdf](#)

[21.197 Distribution Civil Drawings - REVISED.pdf](#)

B. **Announcement of Public Hearing on 21.238 National Grid/Verizon Pole Petition for One (1) Jointly-owned (JO) Pole on Damon Road (Petition#23303524)**

Per M.G.L. Ch. 166, Section 22, the Northampton City Council will hold a public hearing on **Thursday, May 20, 2021 at 7:30 p.m.** on National Grid/Verizon New England's petition to install one jointly-owned (JO) pole on Damon Road (Petition #23303524). Instructions for accessing the hearing may be found on the May 20, 2021 City Council agenda to be posted on the city website (www.northamptonma.gov) at least 48 hours prior to the meeting. The City Council will hear all persons who wish to be heard thereon.

Documents:

[21.238 DPW Recommendation.pdf](#)

[21.238 National Grid-Verizon Pole Petition for Damon Road.pdf](#)

C. **Announcement of Public Hearing on 21.239 National Grid/Verizon Pole Petition for Two (2) Jointly-owned (JO) Poles on Burts Pit Road (Petition#30025210)**

Per M.G.L. Ch. 166, Section 22, the Northampton City Council will hold a public hearing on **Thursday, May 20, 2021 at 7:15 p.m.** on National Grid/Verizon New England's petition to install two jointly-owned (JO) poles on Burts Pit Road (Petition #30025210). Instructions for accessing the hearing may be found on the May 20, 2021 City Council agenda to be posted on the city website (www.northamptonma.gov) at least 48 hours prior to the meeting. The City Council will hear all persons who wish to be heard thereon.

Documents:

[21.239 BPR Plan.pdf](#)

[21.239 DPW Recommendation.pdf](#)

D. Announcement of Public Hearing for 21.261 Application for License to Store Flammables and Combustibles at 140 Olander Drive

Per M.G.L. Chapter 148, Section 13, North Commons at Village Hill, LLC has submitted an application for a License to Store Flammables and Combustibles for one (1) 4,000-gallon LP Gas underground storage tank at 140 Olander Drive, Northampton, MA.

The City Council will hold a public hearing by video conference on **Thursday, May 20, 2021 at 7:05 p.m.** Instructions for accessing the hearing may be found on the May 20, 2021 City Council agenda to be posted on the city website (www.northamptonma.gov) at least 48 hours prior to the meeting.

The City Council will hear all persons who wish to be heard thereon. The City Council meeting begins **at 7 p.m.**

5. Updates from Council President and Committee Chairs

6. Recognitions and One-Minute Announcements by Councilors

7. Communications and Proclamations from the Mayor

A. Municipal Broadband Update

8. Resolutions

A. 21.266 A Resolution in Support of Workers of the Hampshire Gazette - 1st reading

Documents:

[21.266 A Resolution in Support of Workers of the Hampshire Gazette.pdf](#)

B. 21.267 A Resolution in Support of the Recommendations of the Northampton Policing Review Commission - 1st reading

Documents:

[21.267 A Resolution in Support of the Recommendations of the Northampton Policing Review Commission.pdf](#)

9. Presentations

10. Consent Agenda

A. Minutes of April 1, 2021

B. Approve 21.197 National Grid/Verizon Petition for Installation of Underground Conduit on Damon Road (Petition#23303524)

See documents under public hearing above.

C. 21.260 Petition for Second Hand Dealer License - Cancer Connection

Renewal License for:

Cancer Connection, 375 South Street
Applicant: Christine Quinn

Documents:

[21.260 Second Hand Dealer License for Cancer Connection.pdf](#)

D. 21.263 Applications for Seven (7) Taxicab Licenses, Jeffrey Miller - Cosmic Cab Company

Renewal Licenses for Taxi Cabs for the following vehicles:

- 2008 Dodge Grand Caravan - Gray
- 2005 Dodge Magnum - Gray
- 2008 Dodge Grand Caravan - Brown
- 2010 Dodge Grand Caravan - Gray
- 2009 Dodge Grand Caravan - Blue
- 2008 Dodge Grand Caravan - Black
- 2007 Chevrolet Suburban - Brown

Documents:

[21.263 Cosmic Cab Taxi License Applications.pdf](#)

E. 21.268 Reappointments to Various Committees - for referral to City Services Committee

Agricultural Commission

John J. Bobala, 25 Old Ferry Road, Northampton

Term: July 2021-June 2024

Reappointment

Richard E. Jaescke, 774 Bridge Road, Northampton

Term: July 2021-June 2024

Reappointment

Robert Vollinger, 460 North Farms Road, Florence

Term: July 2021-June 2023

Reappointment

Earle “Chip” Parsons, 137 Mill Valley Road, Hadley

Term: July 2021-June 2023

Reappointment

Central Business Architecture Committee

Joseph Blumenthal, 39 Chapel St., Northampton

Term: July 2021-June 2024

Reappointment

Urban Forestry Commission

Susan Lofthouse, 15 Stoddard Street, Northampton

Term: July 2021-June 2024

Reappointment

Council on Aging

Robert Dionne, 87 Vernon Street, Northampton

Term: July 2021-June 2024

Reappointment

Jeanne Hoose, 36 South Park Terrace, Northampton

Term: July 2021-June 2024

Reappointment

Historical Commission

Dylan Gafney, 23 Marshall Street, Northampton

Term: July 2019-June 2022

Reappointment

Barbara Blumenthal, 39 Chapel Street, Northampton

Term: July 2021-June 2024

Reappointment

Housing Partnership

Julio Alves, 35 Fort Hill Terrace, Northampton

Term: July 2021- June 2024

Reappointment

James Reis, 108 Coles Meadow Road, Northampton

Term: July 2021-June 2024

Reappointment

Parks and Recreation Commission

Julia Chevan, 8 Cosmian Avenue, Florence

Term: July 2020-June 2023

Reappointment

Planning Board

George Kohout, Full Member, 234 State Street, Northampton

Term: July 2021-June 2024

Reappointment

Zoning Board of Appeals

Maureen Scanlon, 197 Nonotuck Street, Florence

Term: July 2021-June 2024

Reappointment

Documents:

[21.268 Reappointments to Various Committees.pdf](#)

11. Recess for Committee on Finance (See Separate Agenda)

12. Financial Orders (on 1st reading pending Finance review)

Rule 2.6 requires the Finance Committee to consider certain financial matters.

A. 21.264 An Order for FY2021 Budget Transfers - 1st reading

Documents:

[21.264 An Order for FY2021 Budget Transfers.pdf](#)

B. 21.265 An Order Authorizing Acquisition and Establishment of a Municipal Light Plant - 1st reading

Documents:

[21.265 An Order Authorizing Acquisition and Establishment of a Municipal Light Plant.pdf](#)

13. Financial Orders (on 2nd reading)

A. 21.244 An Order to Acquire and Amend Easements at the Mill River Greenway-Smith College - 2nd reading

History:

- Positive recommendation, Finance Committee - 4/15/2021
- Passed 1st reading - 4/15/2021

Documents:

[21.244 An Order to Acquire and Amend Easements at the Mill River Greenway-Smith College.pdf](#)

B. 21.248 An Order to Appropriate CPA Funds for Historic Northampton Collections Storage - 2nd reading

History:

- Positive recommendation, Finance Committee - 4/15/2021
- Passed 1st reading - 4/15/2021

Documents:

[21.248 An Order to Appropriate CPA Funds for Historic Northampton Collections Storage.pdf](#)

C. 21.249 An Order to Appropriate \$120,000 in CPA Funds Toward Habitat Housing on Burts Pit Road - 2nd reading

History:

- Positive recommendation, Finance Committee - 4/15/2021
- Passed 1st reading - 4/15/2021

Documents:

[21.249 An Order to Appropriate 120,000 in CPA Funds Toward Habitat Housing on Burts Pit Road.pdf](#)

D. 21.250 An Order to Appropriate \$14,500 in CPA Funds to Lilly

Library Stair Repair Project - 2nd reading

History:

- Positive recommendation, Finance Committee - 4/15/2021
- Passed 1st reading - 4/15/2021

Documents:

[21.250 An Order to Appropriate 14,500 in CPA Funds to Lilly Library Stair Repair Project.pdf](#)

E. 21.251 An Order to Appropriate \$70,000 in CPA Funds for Historic Preservation Plan - 2nd reading

History:

- Positive recommendation, Finance Committee - 4/15/2021
- Passed 1st reading - 4/15/2021

Documents:

[21.251 An Order to Appropriate 70,000 in CPA Funds for Historic Preservation Plan.pdf](#)

F. 21.252 An Order to Appropriate \$21,250 in CPA Funds for Damon House/Shepherd Barn Project - 2nd reading

History:

- Positive recommendation, Finance Committee - 4/15/2021
- Passed 1st reading - 4/15/2021

Documents:

[21.252 An Order to Appropriate 21,250 in CPA Funds for Damon House - Shepherd Barn Project.pdf](#)

G. 21.253 An Order to Appropriate \$60,000 in CPA Funds for Mill River Greenway Beach Project - 2nd reading

History:

- Positive recommendation, Finance Committee - 4/15/2021
- Passed 1st reading - 4/15/2021

Documents:

[21.253 An Order to Appropriate 60,000 in CPA Funds for Mill River Greenway Beach Project.pdf](#)

H. 21.254 An Order to Appropriate \$50,000 in CPA Funds to the Affordable Housing Fund - 2nd reading

History:

- Positive recommendation, Finance Committee - 4/15/2021
- Passed 1st reading - 4/15/2021

Documents:

[21.254 An Order to Appropriate 50,000 in CPA Funds to the Affordable Housing Fund.pdf](#)

I. 21.255 An Order Authorizing Acquisition of a Parcel of Land on the Southeasterly Side of Brierwood Drive - 2nd reading

History:

- Positive recommendation, Finance Committee - 4/15/2021
- Passed 1st reading - 4/15/2021

Documents:

[21.255 An Order Authorizing Acquisition of a Parcel of Land on the Southeasterly Side of Brierwood Drive.pdf](#)
[21.255 Order of Taking.pdf](#)
[21.255 Plans - Edbert Homes Inc.pdf](#)

J. 21.256 An Order Authorizing Waiver of Right of First Refusal for 2.93 Acres off Kennedy Road - 2nd reading

History:

- Positive recommendation, Finance Committee - 4/15/2021
- Passed 1st reading - 4/15/2021

Documents:

[21.256 Notice of Non-Exercise.pdf](#)

14. Orders

15. Ordinances (Not yet Referred)

Rule 5.2.3 provides that no ordinance shall be voted on by the City Council until it has been considered by the Committee on Legislative Matters.

16. Florence Traffic & Parking Ordinances Sponsored by Transportation & Parking Commission (TPC)

History:

- Scanlon Avenue and Cross Street Stop Signs (21.198 and 21.199) referred by City Council - 3/4/2021
- Pine/Maple/Mann Intersection & Pine Street Parking (21.213, 21.214, 21.215, 21.216) referred by City Council - 4/1/2021
- All positive recommendations, Legislative Matters - 4/12/2021
- Passed 1st reading - 4/15/2021

A. 21.198 An Ordinance Relative to a Stop Sign on Scanlon Avenue - 2nd reading

Documents:

[21.198 An Ordinance Relative to a Stop Sign on Scanlon Avenue.pdf](#)

B. 21.199 An Ordinance Relative to Stop Signs on Cross Street - 2nd reading

Documents:

[21.199 An Ordinance Relative to Stop Signs on Cross Street.pdf](#)

C. 21.213 An Ordinance Relative to Parking on Pine Street - 2nd reading

Documents:

[21.213 An Ordinance Relative to Parking on Pine Street.pdf](#)

D. 21.214 An Ordinance Relative to Stop Signs on Maple Street, Mann Terrace and Pine Street - 2nd reading

Documents:

[21.214 An Ordinance Relative to Stop Signs on Maple Street, Mann Terrace and Pine Street.pdf](#)

E. 21.215 An Ordinance Relative to Turning Restriction on Mann Terrace - 2nd reading

Documents:

[21.215 An Ordinance Relative to Turning Restriction on Mann Terrace.pdf](#)

F. 21.216 An Ordinance Relative to One-Way Street on Mann Terrace - 2nd reading

Documents:

[21.216 An Ordinance Relative to One-Way Street on Mann Terrace.pdf](#)

17. Ordinances

18. Information Requests (Charter Provision 2-7) and Committee Study Requests

19. New Business

20. Adjourn

Contact: G-L Sciarra, Council President
glsciarra@northamptonma.gov
(413) 570-3133



**CITY OF NORTHAMPTON, MASSACHUSETTS
DEPARTMENT OF PUBLIC WORKS
125 Locust Street
Northampton, MA 01060**

**413-587-1570
Fax 413-587-1576**

**Donna LaScaleia
Director**

Memorandum

To: Donna LaScaleia, Director of Public Works *Approved M 4-1-2021*
From: David Veleta, City Engineer
Date: March 31, 2021
Re: Council Order 21.197 – Petition for Installation and Maintenance of Underground Conduit and Manholes No. 23303524 – Damon Road Reconstruction Project MassDOT No. 608236 – Damon Road

I have reviewed Department of Public Works (DPW) records and submittals including images, sketches and reconstruction plans for MassDOT Damon Road project No. 608236. This petition with a revised plan dated March 24, 2021, includes the proposed construction of a line of underground electric conduits and manholes, including the necessary sustaining and protecting features, under and across the public ways or ways, by National Grid, referenced in City Council Order 21.197.

The installation is proposed to be located beginning at a point approximately 178 feet northeast of the centerline of the intersection of Industrial Drive and Damon Road and continuing in a northeast direction. National Grid proposes to install Manhole 1 with approximately 20 feet of four 5-inch, future use conduit to the northwest, approximately 45 feet of two 5-inch conduit to pole P7-25, approximately 377 feet of six 5-inch conduit from Manhole 1 to Manhole 2, approximately 37 feet of two 5 inch conduit from Manhole 2 to P7-50, and approximately 20 feet of four 5-inch, future use conduit to the northeast from Manhole 2, as shown on the attached plan dated March 24, 2021.

No potential conflicts were observed, but the contractor shall use caution when excavating since the exact location of the existing sewer force main is unknown.

A trench permit approved by the DPW has already been issued for the Damon Road project to Gagliarducci Construction who will be installing the manholes and conduit under contract with MassDOT. This permit will be revised to reflect the specifics of the above work upon approval of this petition by Council.

Pole & UG Petition/Permit Request Form

City

Town of _____ **WR #** _____
(circle one)

Install _____ **SO**
(quantity) **JO Poles on** _____
(circle one) (street name)

Remove _____ **SO**
(quantity) **JO Poles on** _____
(circle one) (street name)

Relocate _____ **SO**
(quantity) **JO Poles on** _____
(circle one) (street name)

Beginning at a point approximately _____ **feet** _____ **of the centerline**
(distance) (compass heading)

of the intersection of _____
(street name)

and continuing approximately _____ **feet in a** _____ **direction.**
(distance) (compass heading)

Install underground facilities:

Street(s) _____

Description of Work:

ENGINEER _____



DATE _____

DISTRIBUTION CIVIL DRAWINGS

DAMON RD NORTHAMPTON, MA

DRAWING LIST	
DRAWING NO.	CONTENT
G-0	COVER SHEET
G-1	GENERAL NOTES
PP-1 + PP-2	PLAN & PROFILE
DET-1	MANHOLE CARDS
DET-2	MANHOLE/CONDUIT/RISER DETAILS



 124 Grove St. Franklin, MA 02038		PROJECT NO: 270728			
REV DESCRIPTION DATE DES CHK APP		DESIGNED AS DRAWN CHECKED APPROVED		MASSDOT DAMON RD LAYOUT PLAN	
REV. 1 REV. 2		DATE: 3/24/21 SCALE: NTS		 G-0 WR#23303524	

GENERAL NOTES:

- CONTRACTOR TO PROVIDE AS-BUILT INFORMATION 10 DAYS AFTER COMPLETION OF CONDUIT INSTALLATION WORK.
- THE LOCATIONS OF UNDERGROUND STRUCTURES SHOWN HEREIN ARE DEPICTED ACCORDING TO THE BEST AVAILABLE INFORMATION. THEY ARE NOT GUARANTEED TO BE CORRECT OR COMPLETE. IT IS THE RESPONSIBILITY OF THE CONTRACTOR TO CONFIRM ALL CONDITIONS IN THE FIELD AND MAKE ADJUSTMENTS AS REQUIRED TO ACCOMMODATE THE WORK BY GETTING APPROVAL FROM NATIONAL GRID CONSTRUCTION MANAGEMENT FIRST. IT IS ASSUMED ALL PREMISES HAVE WATER, GAS, TEL. ELEC. SEWER, ETC. LATERAL CROSSINGS WHICH SHOULD BE INCLUDED IN THE BASE BID.
- ANY QUESTIONS REGARDING THE CIVIL ENGINEERING DESIGN OF THESE CONSTRUCTION PLANS SHOULD BE REFERRED TO TRC DISTRIBUTION ENGINEER DANIEL LOPEZ AT 774-235-2603 OR DAVID TERK AT 508-298-1523.
- DO NOT DEVIATE FROM THESE PLANS WITHOUT FIRST CONTACTING NATIONAL GRID CIVIL CONSTRUCTION SUPERVISOR:
 - GARY BELLOW 413-652-9222
- ALL UNDERGROUND CONSTRUCTION SHALL BE INSPECTED AND APPROVED BY NATIONAL GRID PERSONAL PRIOR TO CONCRETE ENCASMENT AND BACKFILL. CONTRACTOR SHALL MANDREL, PROVE, AND INSTALL MULE TAPE IN ALL CONDUITS PER NATIONAL GRID CONSTRUCTION STANDARDS UNDER SUPERVISION OF NATIONAL GRID CONSTRUCTION SUPERVISOR.
- CONTRACTOR TO ARRANGE TO HAVE ALL FOREIGN UTILITIES VERIFY THEIR LOCATIONS IN THE FIELD PRIOR TO START OF EXCAVATION WORK BY CONTACTING DIG SAFE AT "811", 1-888-DIG-SAFE. NOT ALL UTILITY SERVICES TO PROPERTIES ARE SHOWN ON THESE PLANS. REFER TO NOTE 2 ABOVE.
- PROTECT ALL MUNICIPAL, STATE, AND FEDERAL SURVEY CONTROL MONUMENTS AND BENCH MARKS. CONTRACTOR TO CONTACT RESPECTIVE MUNICIPAL ENGINEERING DEPARTMENTS FOR TYPES AND LOCATIONS BEFORE STARTING WORK AS REQUIRED.
- PROTECT ALL PLANTS AND TREES AND THEIR ROOT SYSTEMS FROM MECHANICAL AND ENVIRONMENTAL DAMAGE DURING EXCAVATION. BACKFILL ROOT AREAS WITH SOIL HAVING TEXTURE AND FERTILITY TO SUSTAIN PLANT LIFE. CONTRACTOR TO REMOVE ALL ROOTS OF DEAD TREE STUMPS FROM TRENCH PRIOR TO PLACING CONDUIT. CONTRACTOR IS RESPONSIBLE FOR THE INSTALLATION AND MAINTENANCE OF NECESSARY EROSION CONTROL (SILT SACKS, HAY BALES, CHECK DAMS, ETC.) APPROVED BY THE STATE, CITY/TOWN, AND QUONSET DEVELOPMENT CORPORATION AS REQUIRED FOR THE DURATION OF THE PROJECT.
- THE FOLLOWING MINIMUM CLEARANCES SHALL BE MAINTAINED UNLESS OTHERWISE NOTED:

UTILITY	CROSSING	PARALLEL
GAS MAIN	12"	12"
GAS SERVICE	12"	12"
WATER MAIN	12"	12"
WATER SERVICE	12"	12"
TELEPHONE/COMMUNICATION FACILITIES	12"	12"
STORM & SANITARY SEWERS	12"	12"
RAIL ROAD CROSSINGS	50"	50"

PLEASE NOTE, ANY DEVIATIONS FROM THESE MINIMUM CLEARANCES MUST BE REVIEWED AND APPROVED BY NATIONAL GRID & TRC.

UTILITY SERVICES AND LATERALS TO BUILDINGS ARE NOT SHOWN ON THESE PLANS. CONTRACTOR TO VERIFY THEIR LOCATIONS IN THE FIELD AND SUPPORT, PROTECT, MAINTAIN, AND WORK AROUND THEM AS REQUIRED IN ORDER TO COMPLETE THE PROPOSED WORK.

- ALL CONTRACTORS SHALL COMPLY WITH MINIMUM WORKING CLEARANCES FROM ALL ENERGIZED OVERHEAD EQUIPMENT AND CONDUCTORS PER OSHA REGULATIONS 1910.3333. IF MINIMUM WORKING CLEARANCES CAN NOT BE MET, CONTRACTOR MUST CONTACT NATIONAL GRID TO EVALUATE ALTERNATIVE MEASURES. THESE MEASURES MAY INCUR ADDITIONAL COSTS.
- CONDUIT TO BE PLACED AT MINIMUM 30" BELOW ELEVATION OF NEAREST PORTION OF ROAD PAVEMENT UNLESS OTHERWISE NOTED. MANHOLE ROOF TO HAVE A MINIMUM 18" OF COVER FROM FINISH GRADE UNLESS OTHERWISE NOTED.
- ALL WORK SHALL COMPLY WITH ALL APPLICABLE FEDERAL, STATE, AND MUNICIPAL CODES, AS WELL AS THE REQUIREMENTS OF THE NATIONAL ELECTRIC SAFETY CODE, OSHA REGULATIONS AND NATIONAL GRID CONSTRUCTION STANDARDS/REQUIREMENTS.
- AREAS WHERE EXCAVATION IS IN ROCK LEDGE, PROVIDE A SIX (6) INCH MINIMUM SELECT FILL CUSHION AROUND CONDUITS AND TWELVE (12) INCH CUSHION AROUND MANHOLE.

- CONTRACTOR SHALL COMPLY WITH ALL APPLICABLE FEDERAL, STATE AND LOCAL REGULATIONS REGARDING REMOVAL AND/OR DISPOSAL OF ANY AND ALL EQUIPMENT AND MATERIALS.
- CONTRACTOR SHALL MAINTAIN A FULL SIZE SET OF SCALED DRAWINGS (100% OF ALL PRINTS) ON SITE AT ALL TIMES DURING THE WORK.
- CONTRACTOR TO RECORD AND DOCUMENT A SINGLE, MULTI-PAGE .PDF PHOTOLOG OF THE ENTIRE WORK AREA. CONTRACTOR TO PROVIDE NATIONAL GRID PROJECT MANAGER A COPY OF THE PRE-CONSTRUCTION PHOTOLOG ALONG WITH A POST-CONSTRUCTION PHOTOLOG OF THE ENTIRE WORK AREA UPON COMPLETION OF ALL CIVIL WORK IN THE FIELD.
- REFER TO ALL NATIONAL GRID CIVIL CONSTRUCTION SPECIFICATIONS INCLUDED IN THE BID DOCUMENTS FOR ADDITIONAL INFORMATION REGARDING MANHOLE AND DUCT BANK INSTALLATION.

PLEASE NOTE:
THE 12" MINIMUM CLEARANCES FROM OTHER UTILITIES SHALL BE MAINTAINED WHEREVER POSSIBLE. IF THE 12" MINIMUM CLEARANCE CANNOT BE ACHIEVED IN THE FIELD, CONTRACTOR TO USE ACCEPTABLE ALTERNATIVE MEANS TO PROTECT THE OTHER UTILITIES AND/OR CONFIRM APPROVAL FROM THE UTILITY OWNER FOR LESS THAN MINIMUM CLEARANCE.

DISTRIBUTION DRAWING INDEX

REFER TO DRAWINGS:

CIVIL & PROFILE DRAWINGS	PROPOSED MANHOLE DRAWINGS	DETAIL DRAWINGS
PP-1	DET-1	DET-1
		DET-2

ABBREVIATIONS

NOTE: NOT ALL ABBREVIATIONS LISTED BELOW ARE USED FOR THIS PROJECT

#	NUMBER	HV	HIGH VOLTAGE
&	AND	INV	INVERT
⊙	AT	KV	KILOVOLT
>	GREATER THAN	KVA	KILOVOLT-AMPERE
<	LESS THAN	L	LENGTH
∅	DIAMETER	LF	LINEAR FOOT
A	AMPERE	LV	LOW VOLTAGE
ABAN	ABANDONED	M	METER
ABAND	ABANDONED	MAX	MAXIMUM
AC	AIR CONDITIONER	MH	MANHOLE
AC	ALTERNATING CURRENT	MIN	MINIMUM
APPROX. APP	APPROXIMATE	MISC	MISCELLANEOUS
B/	BOTTOM OF	MJ	MECHANICAL JOINT
BIT	BITUMINOUS	MW	MONITORING WELL
BLDG	BUILDING	N	NORTH
BVCE	BEGIN VERTICAL CURVE ELEVATION	N/F	NOW OR FORMERLY
BVCS	BEGIN VERTICAL CURVE STATION	NGVD	NATIONAL GEODETIC VERTICAL DATUM
C/C	CENTER TO CENTER	NIOSH	NATIONAL INSTITUTE OF OCCUPATIONAL SAFETY AND HEALTH
CB	CATCH BASIN	PC	POINT OF CURVATURE
CI	CAST IRON	PCB	POLYCHLORINATED BIPHENYL
CL	CENTERLINE	PE	POLYETHYLENE
CLR	CLEAR	PILC	PAPER IN LEAD COVERED CABLE
CMP	CORRUGATED METAL PIPE	PIV	POST INDICATOR VALVE
CMPA	CORRUGATED METAL PIPE ARCH	PROP	PROPOSED
CMPT	COMPACT CABLE	PT	POINT, POINT OF TANGENCY
COM	COMMUNICATIONS	PVC	POLYVINYL CHLORIDE
CONC	CONCRETE	PVI	POINT OF VERTICAL INTERSECTION
CP	CONTROL POINT	R	RADIUS
CS	CARBON STEEL	RCP	REINFORCED CONCRETE PIPE
CU	COPPER	REQ'D	REQUIRED
CW	CLEAN WATER	RET	RETAINING
D	DIAMETER	RR	RAIL ROAD
DC	DIRECT CURRENT	S	SLOPE
DI	DUCTILE IRON	SCADA	SUPERVISORY CONTROL AND DATA ACQUISITION
DIA	DIAMETER	SCH	SCHEDULE
DMH	DRAIN MANHOLE	SD	STORM DRAIN
DWG	DRAWING	SF	SQUARE FEET
E	EAST	SMH	SANITARY MANHOLE
EL	ELEVATION	SQ	SQUARE
ELEC	ELECTRIC	SS	STAINLESS STEEL
ELEV	ELEVATION	STA	STATION
EMH	ELECTRIC MANHOLE	STL	STEEL
EOP	EDGE OF PAVEMENT	STORM	STORMWATER
EUE	EXISTING UNDERGROUND ELECTRIC	T&B	TOP AND BOTTOM
EUT	EXISTING UNDERGROUND TELEPHONE	T/	TOP OF
EVCE	END VERTICAL CURVE ELEVATION	TEL	TELEPHONE
EVCS	END VERTICAL CURVE STATION	TV	TELEVISION
EW	EACH WAY	TYP	TYPICAL
EX, EXIST	EXISTING	UE	UNDERGROUND ELECTRIC
FFE	FINISH FLOOR ELEVATION	UG	UNDERGROUND
FM	FORCE MAIN	UNO	UNLESS NOTED OTHERWISE
FO	FIBER OPTIC	V	VOLT
GALV	GALVANIZED	vAr	VOLT-AMPERE REACTIVE
GEN	GENERATOR	VC	VERTICAL CURVE
GRAN	GRANITE	VCP	VITREOUS CLAY PIPE
HDD	HORIZONTAL DIRECTIONAL DRILLING	VERT	VERTICAL
HDPE	HIGH DENSITY POLYETHYLENE	VP	VALVE PIT
HH	HANDHOLE	W	WATER
HORIZ	HORIZONTAL	W/	WITH

LEGEND

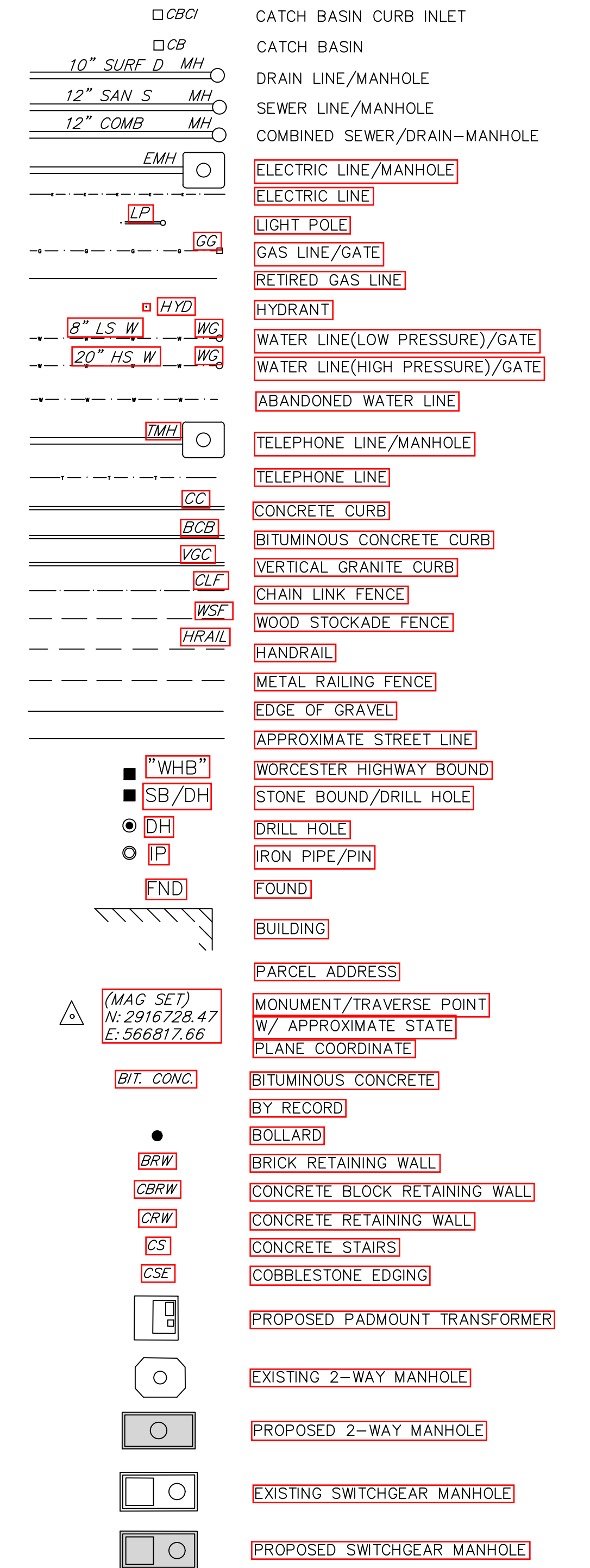

<p>124 Grove St. Franklin, MA 02038</p>		PROJECT No:270728		DESIGNED	
				DRAWN	
MASSDOT DAMON RD LAYOUT PLAN				CHECKED	
APPROVED				APPROVED	
REV 1	DATE	3/24/21	SCALE	DATE	3/24/21
REV 2	DATE		SCALE	DATE	
WR#23303524					REV

PB/PG 39/15
PB/PG 181/211
32 DAMON RD

DAMON ROAD CONST. # STA. 22+56.11 =
INDUSTRIAL DR CONST. # STA. 300+00.00

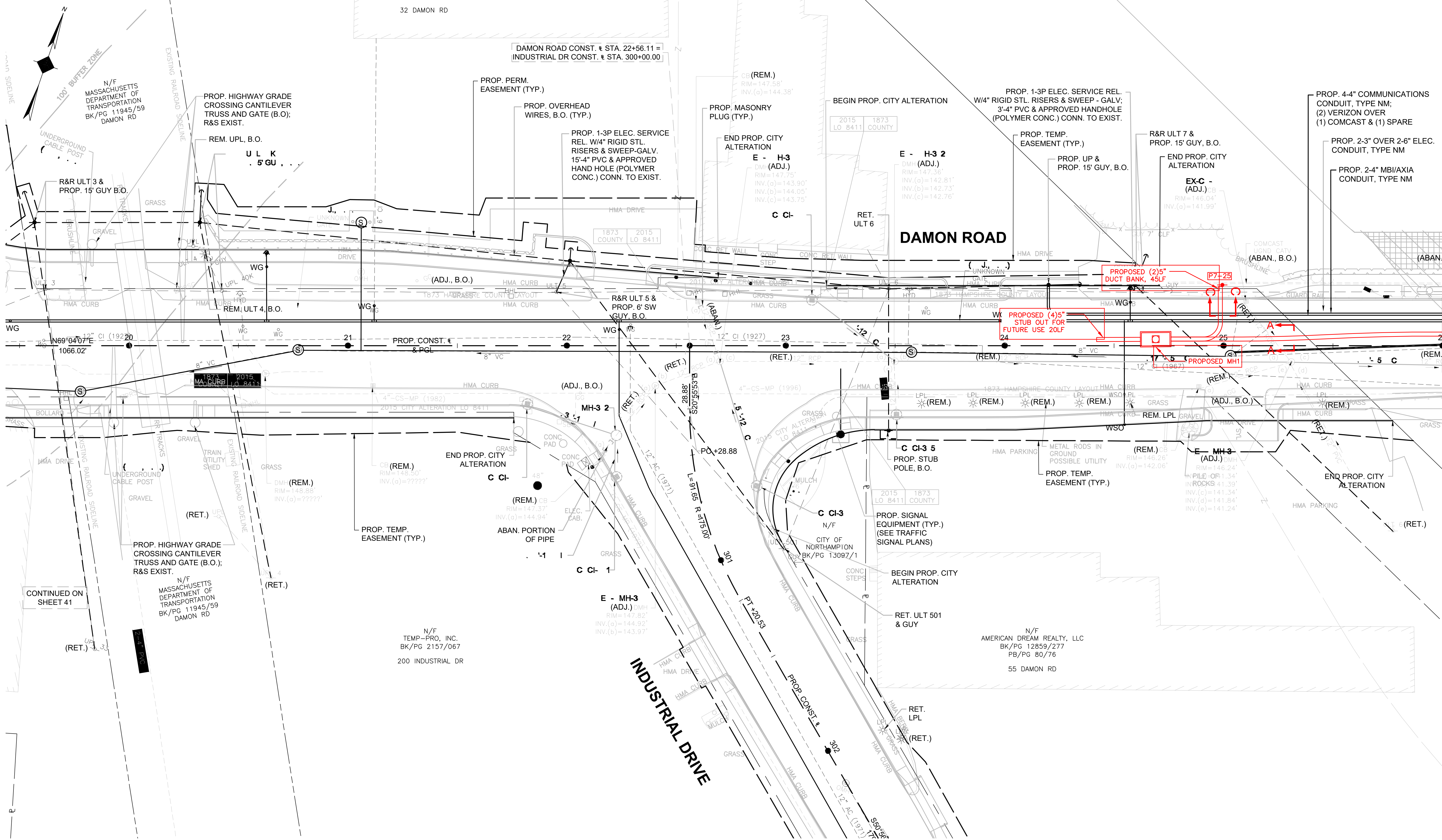

SEE PAGE PP-2

CONTINUED ON SHEET 41

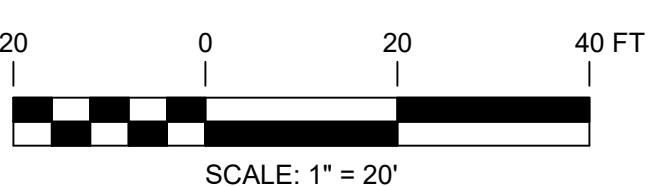

124 Grove St. Franklin, MA 02038		PROJECT NO: 270728			
DESIGNED	AS DRAWN	CHECKED	APPROVED	MASSDOT DAMON RD LAYOUT PLAN	
REV 1	3/24/21	DATE	AS NOTED	SCALE	PP-1
REV 2					WR#23303524

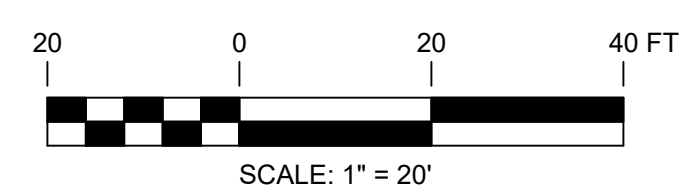
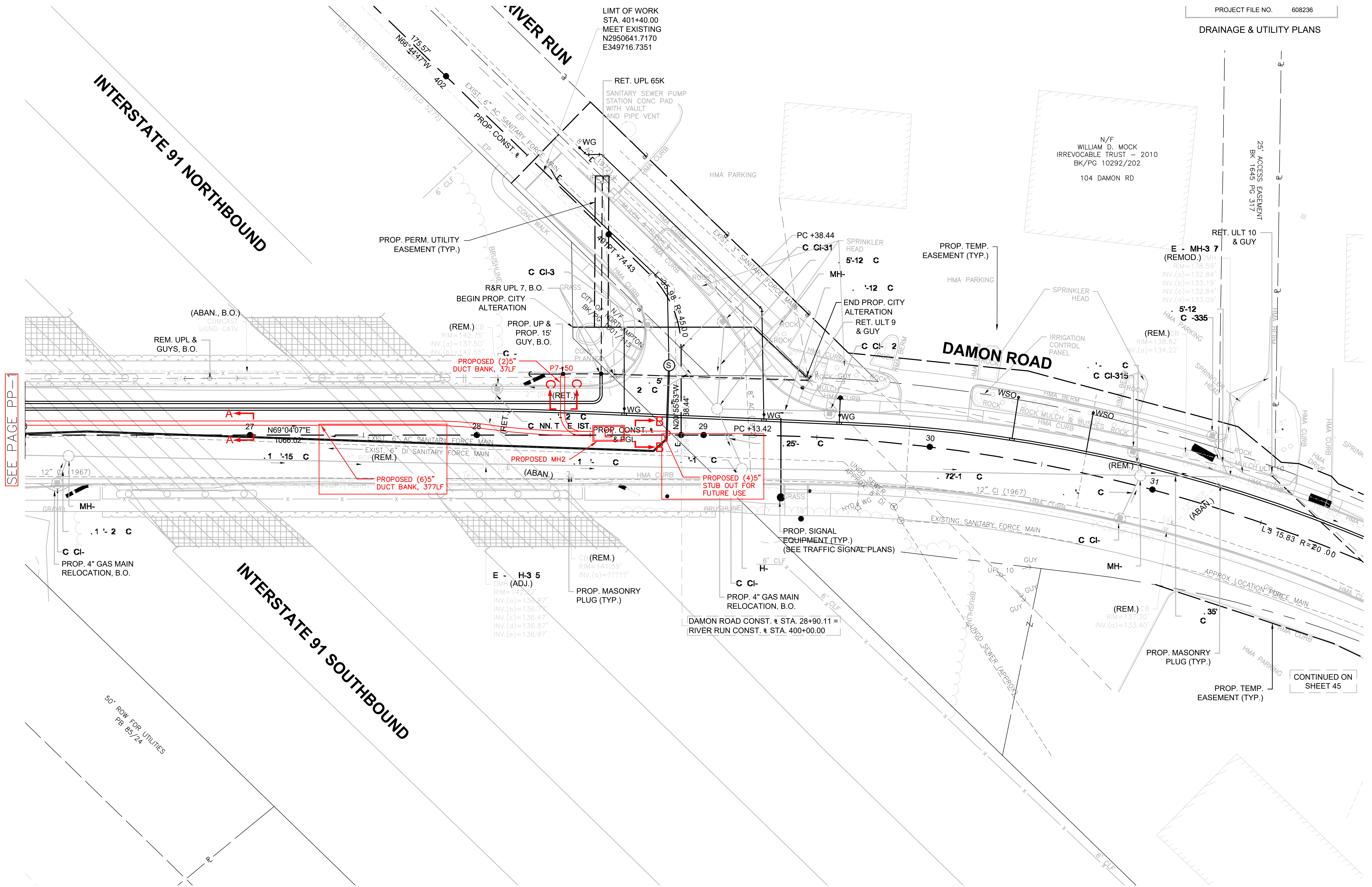
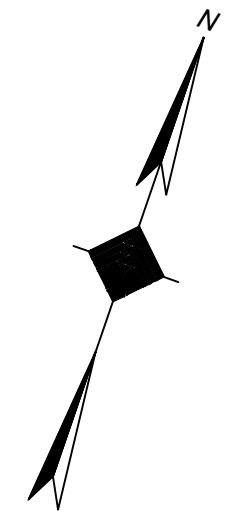

124 Grove St. Franklin, MA 02038		PROJECT NO. 270728																								
<table border="1"> <thead> <tr> <th>REV</th> <th>DESCRIPTION</th> <th>DATE</th> <th>DES</th> <th>CHK</th> <th>APP</th> </tr> </thead> <tbody> <tr> <td> </td> <td> </td> <td> </td> <td> </td> <td> </td> <td> </td> </tr> </tbody> </table>	REV	DESCRIPTION	DATE	DES	CHK	APP							<table border="1"> <tr> <td>DESIGNED</td> <td>AS</td> <td>CHECKED</td> <td>APPROVED</td> </tr> <tr> <td> </td> <td> </td> <td> </td> <td> </td> </tr> </table>				DESIGNED	AS	CHECKED	APPROVED					MASSDOT DAMON RD LAYOUT PLAN	
REV	DESCRIPTION	DATE	DES	CHK	APP																					
DESIGNED	AS	CHECKED	APPROVED																							
<table border="1"> <tr> <td>REVIEW 1</td> <td>3/24/21</td> <td>DATE</td> <td>PP-2</td> <td>REV.</td> </tr> <tr> <td>REVIEW 2</td> <td>AS NOTED</td> <td>SCALE</td> <td>WR#23303524</td> <td>0</td> </tr> </table>	REVIEW 1	3/24/21	DATE	PP-2	REV.	REVIEW 2	AS NOTED	SCALE	WR#23303524	0																
REVIEW 1	3/24/21	DATE	PP-2	REV.																						
REVIEW 2	AS NOTED	SCALE	WR#23303524	0																						

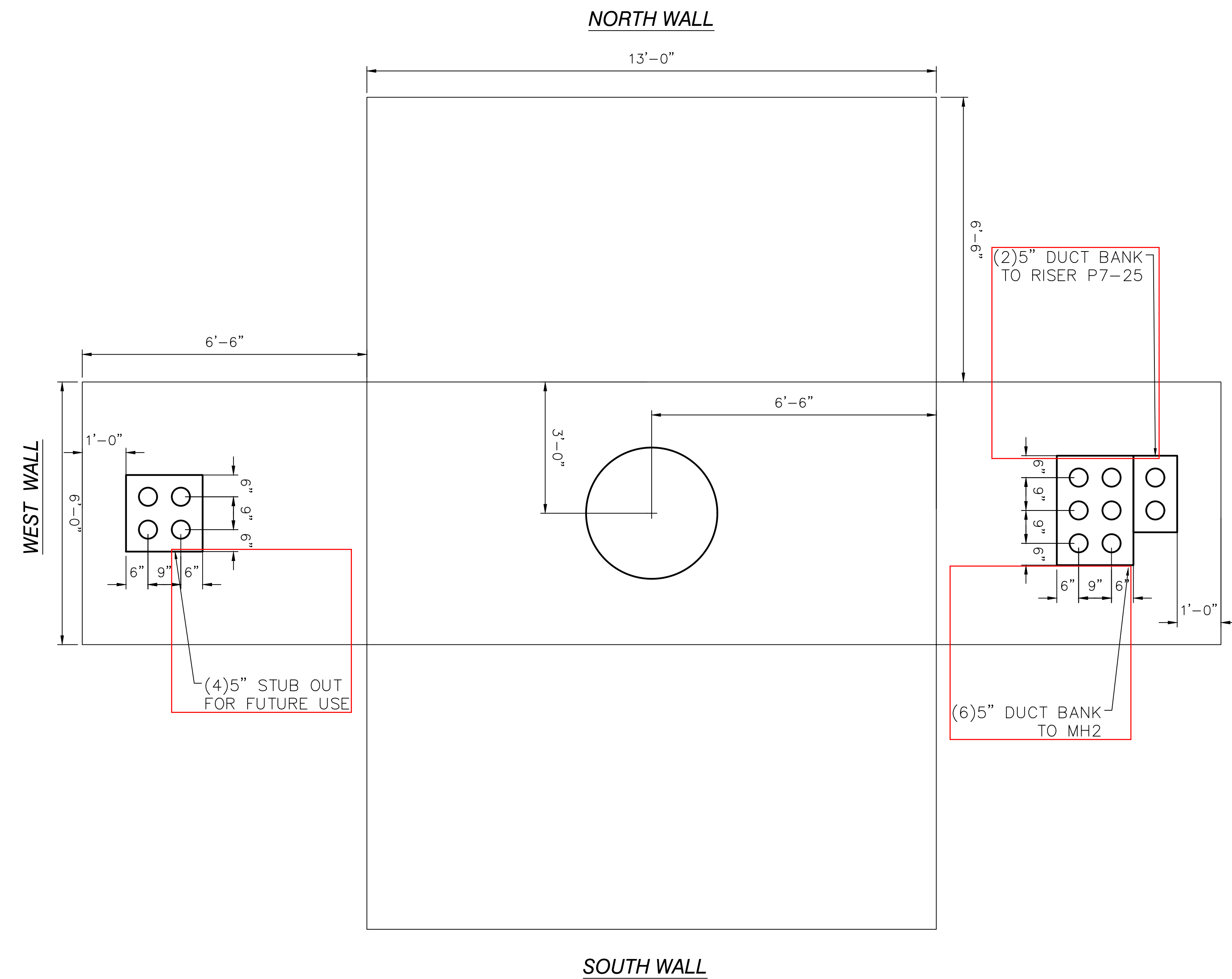

MANHOLE NUMBER: MH1

SIZE: L=13' W=6' H=6'-6"
 MANHOLE RING SIZE: 36"
 MANHOLE COVER SIZE: 26"
 CHIMNEY HEIGHT: 2'-0"

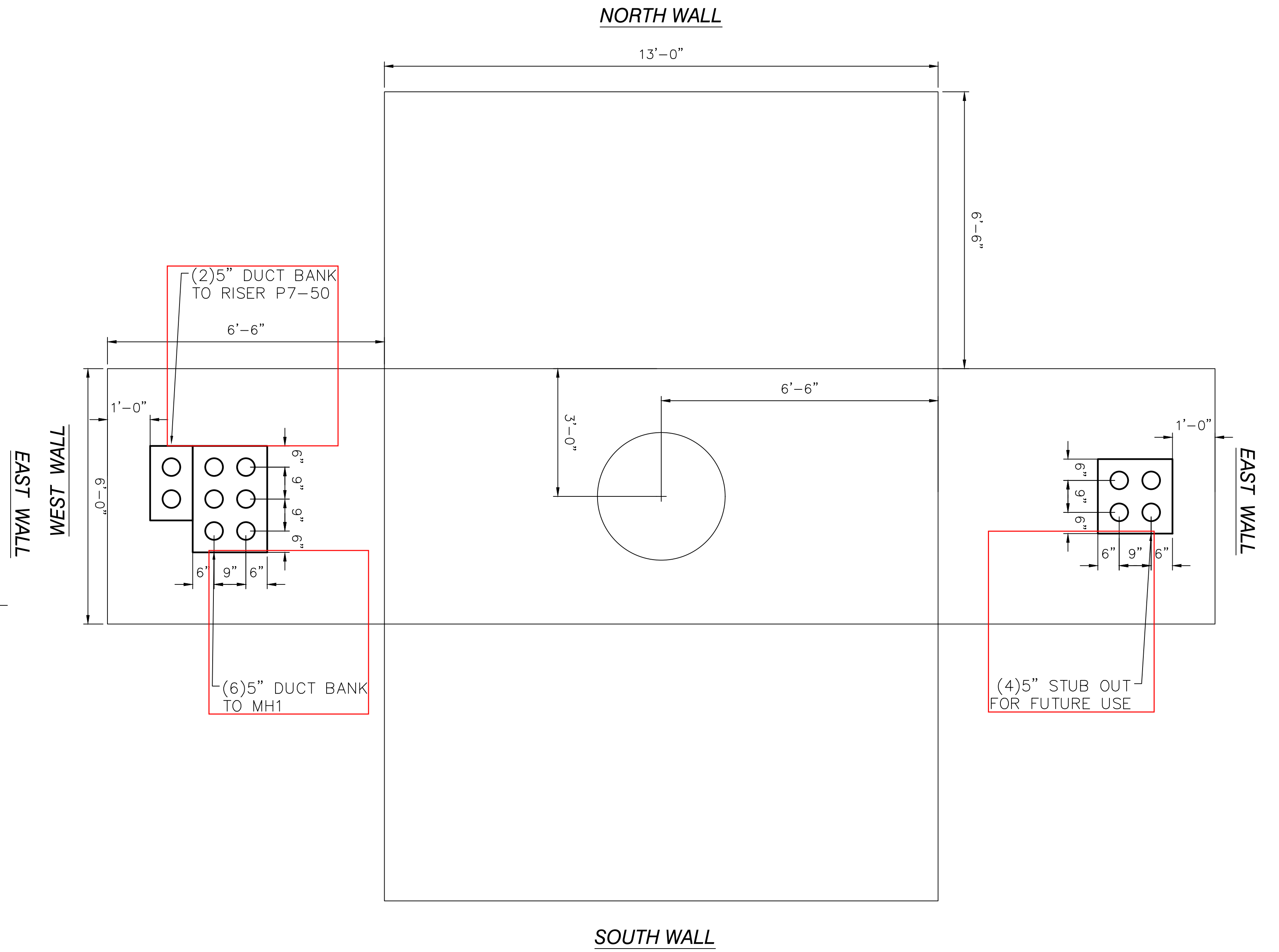

MANHOLE NUMBER: MH2

SIZE: L=13' W=6' H=6'-6"
 MANHOLE RING SIZE: 36"
 MANHOLE COVER SIZE: 26"
 CHIMNEY HEIGHT: 2'-0"

		124 Grove St. Franklin, MA 02038		PROJECT NO: 270728			
REV	DESCRIPTION	DATE	DES	CHK	APP		

DESIGNED		MASSDOT DAMON RD LAYOUT PLAN
DRAWN		
CHECKED		
APPROVED		
REVIEW 1	3/24/21	
REVIEW 2	NTS	
	SCALE	DET-1
		WR#23303524

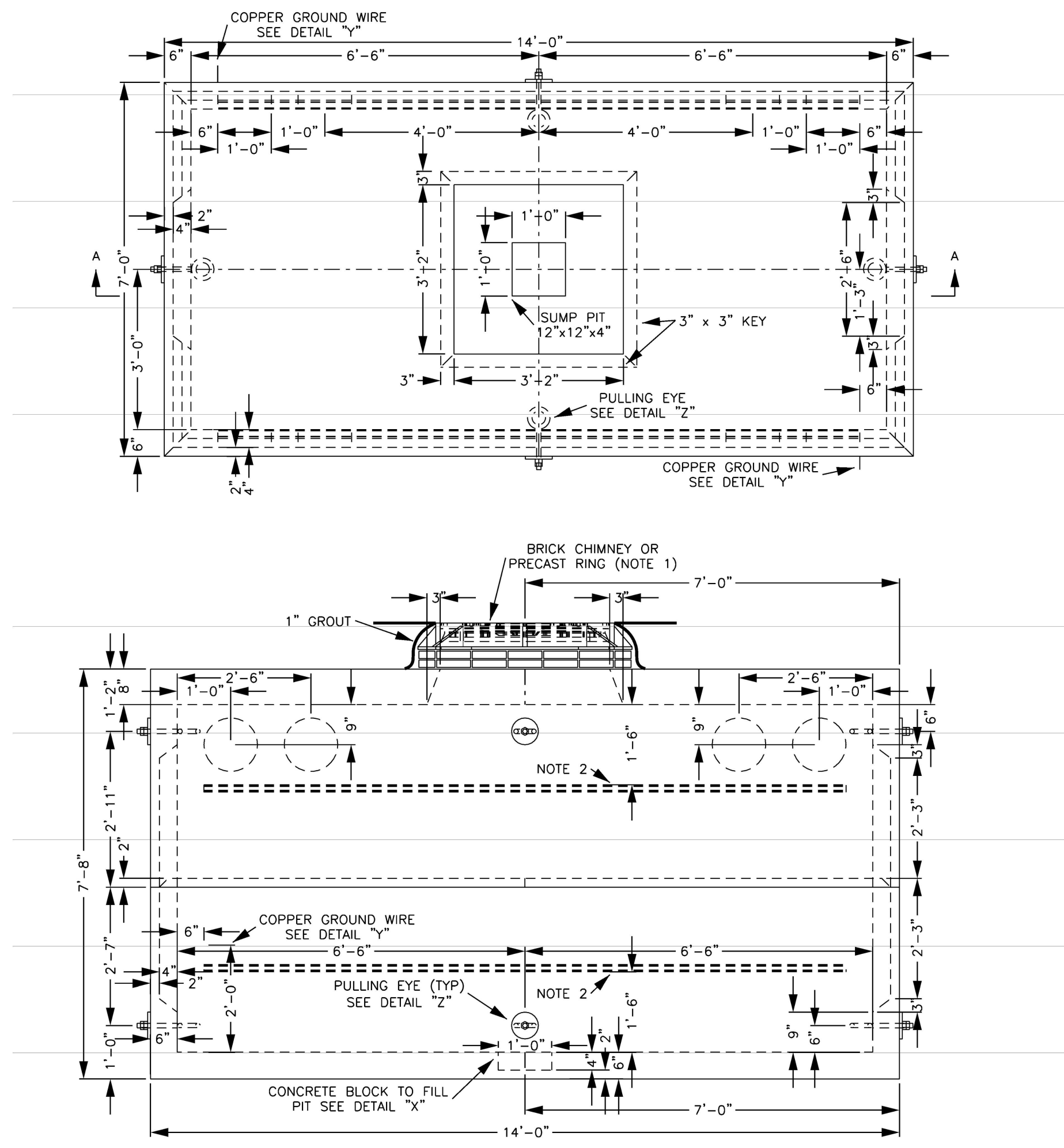
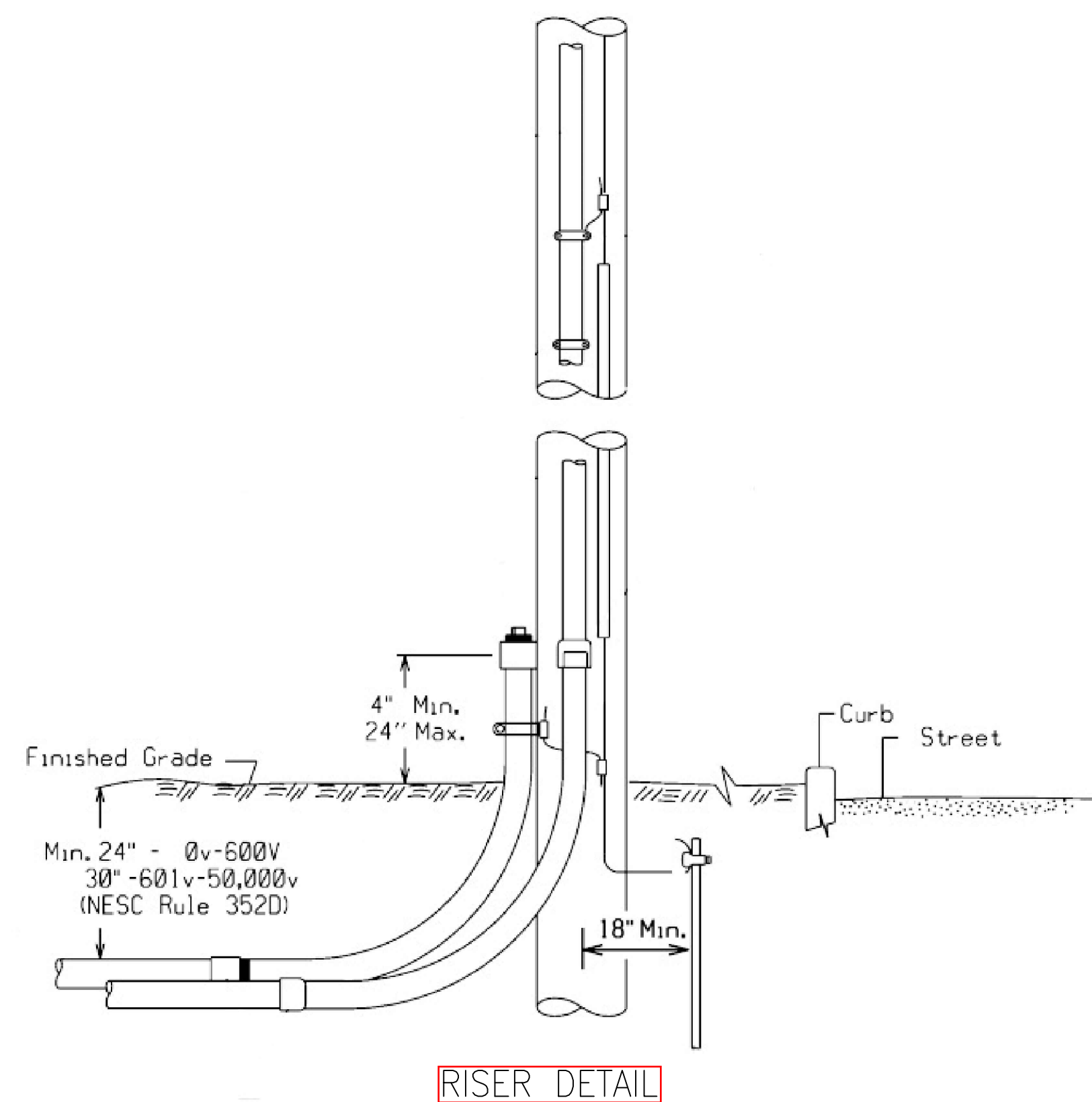
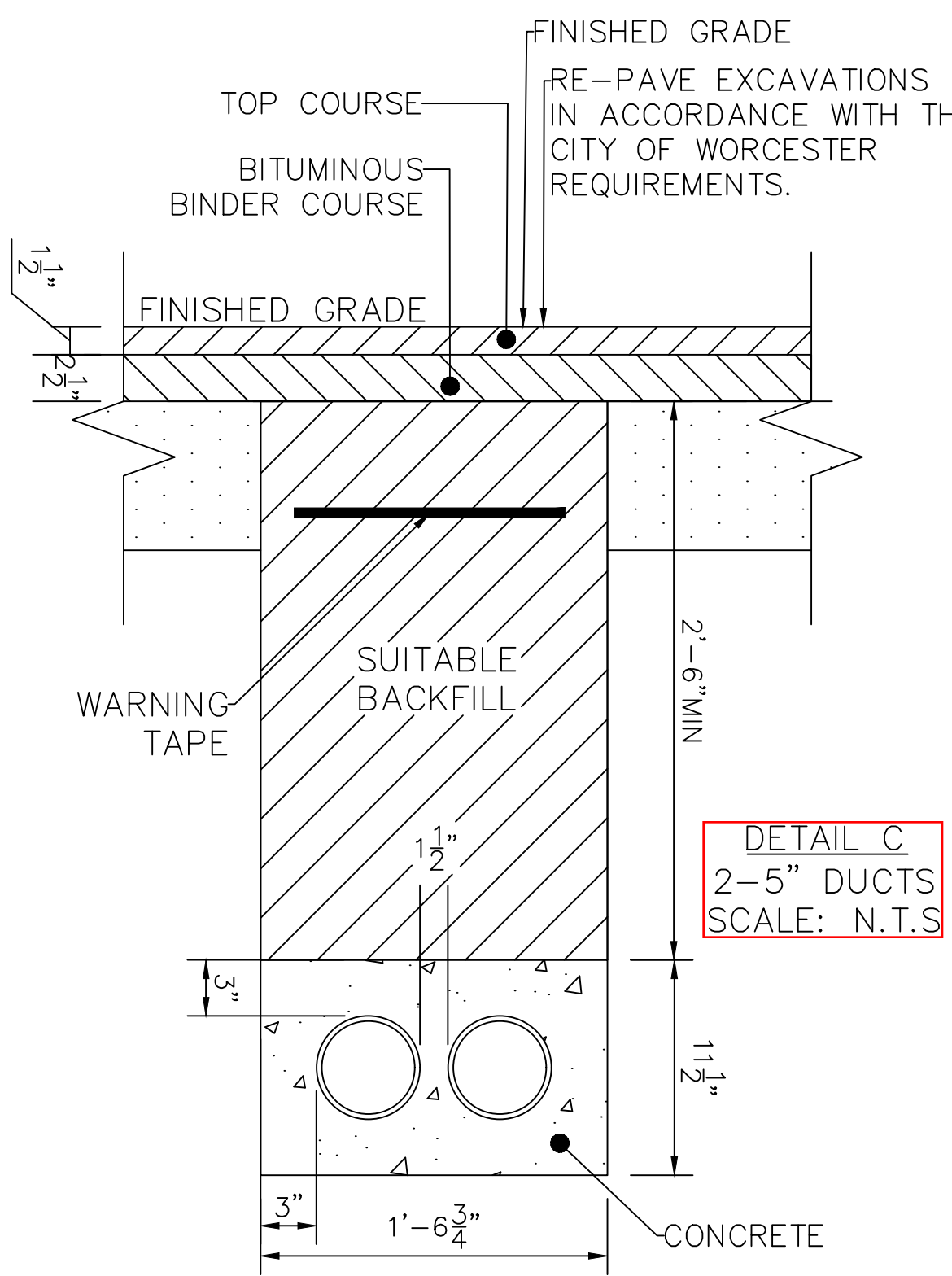
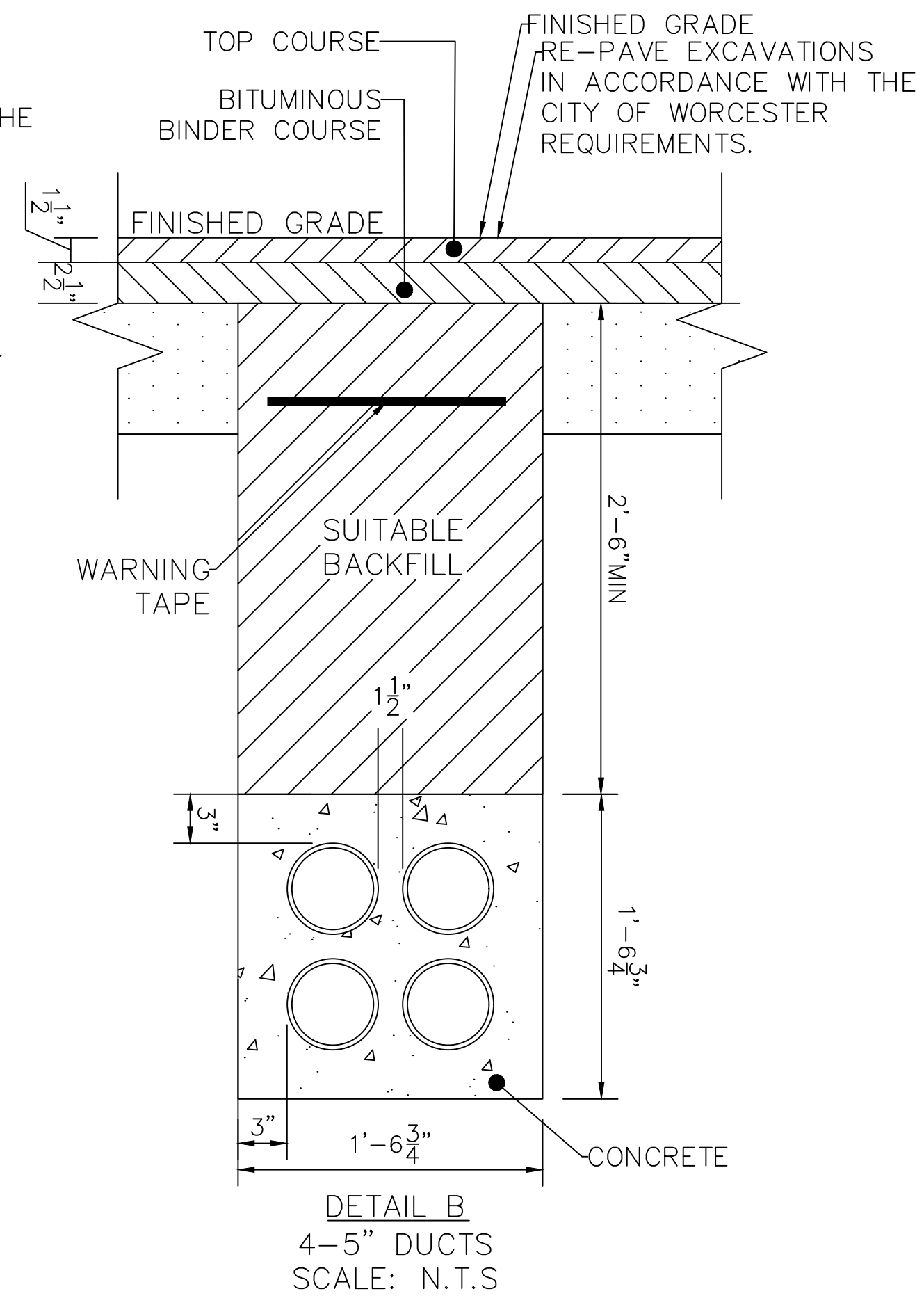
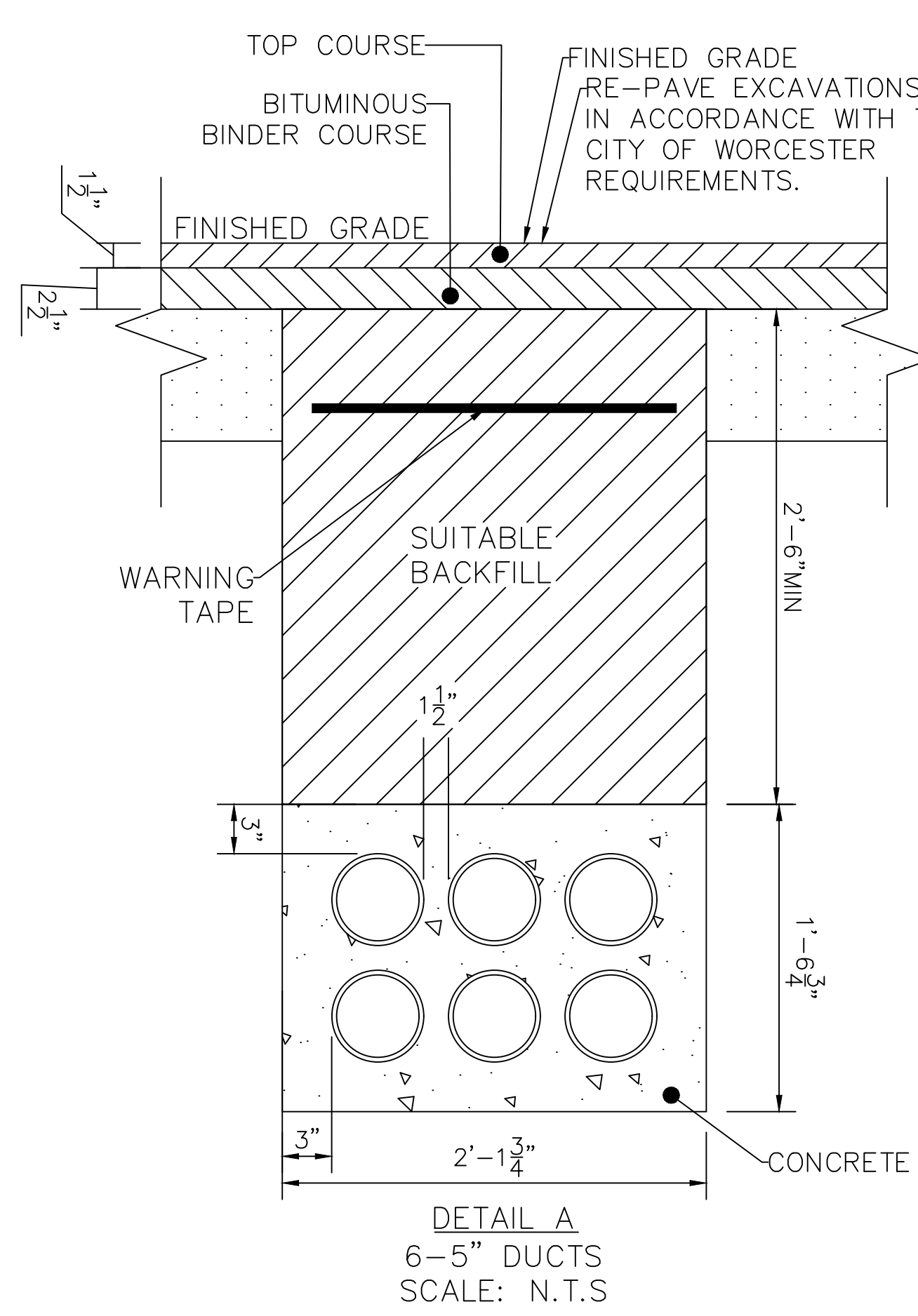

NOTE
 1. FOR MANHOLE CHIMNEY OR PRECAST RING SEE MS 3748, 3755 AND 3757. USE WITH UM14F(36" FRAME), UM14R(26"-36" RING) AND UM14C(26" COVER).
 2. INSTALL 1-3/8"x1-3/8" HEAVY DUTY GALVANIZED UNISTRUT AND CABLE POSITIONING BRACKETS. UNISTRUT NEEDS TO BE PROPERLY BONDED TO THE GROUND GRID WITH A TINNED CONNECTOR AND 4/0 CABLE.

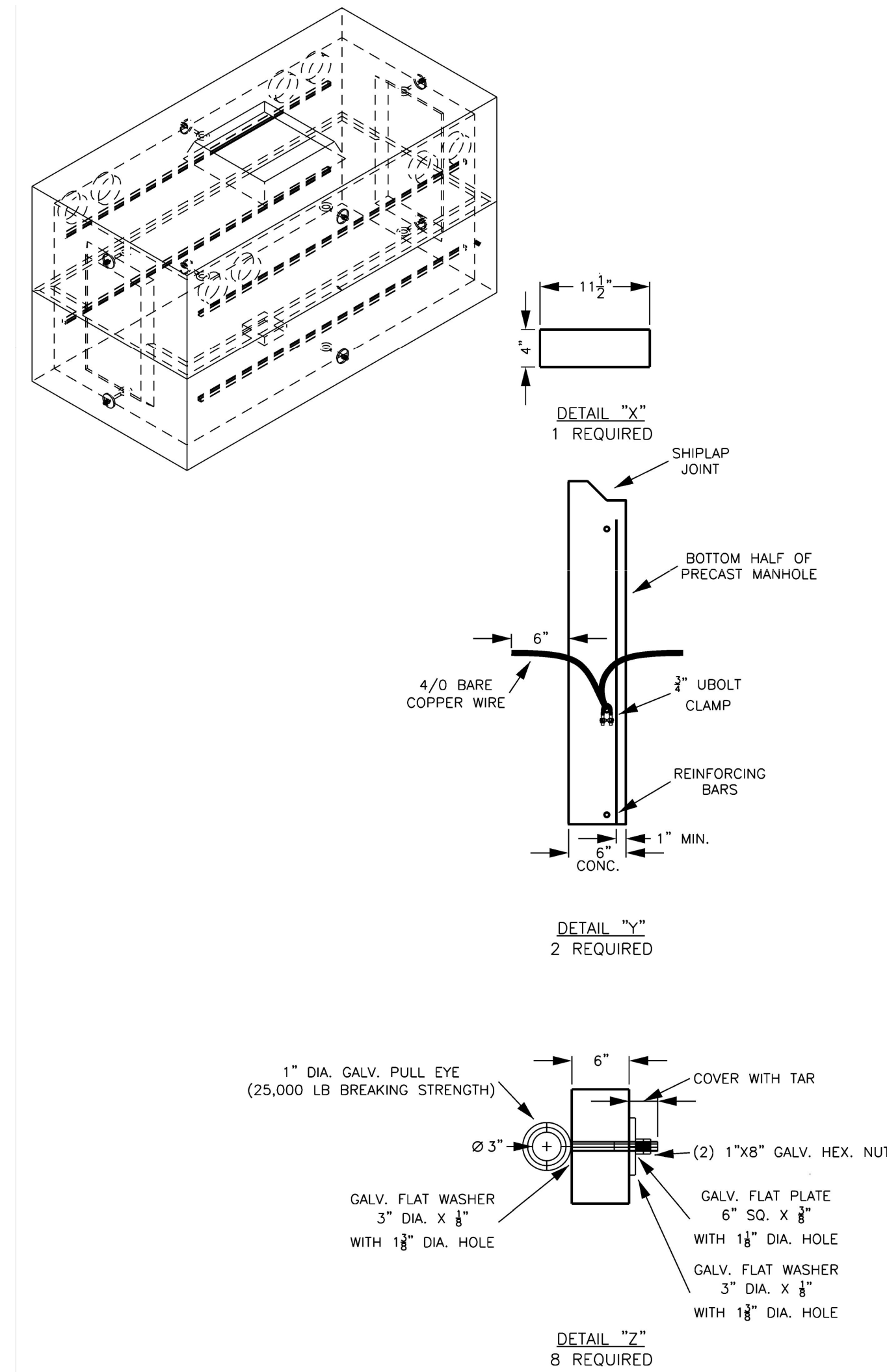

TYPICAL 2 WAY MANHOLE DETAIL

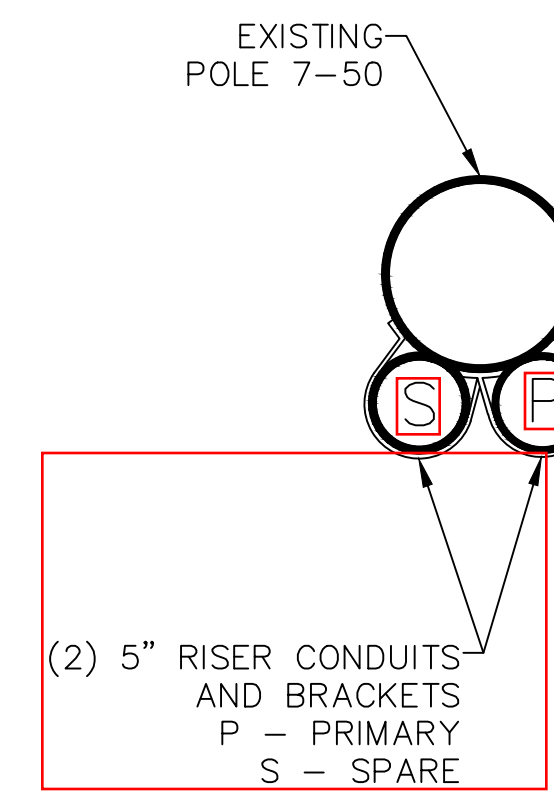
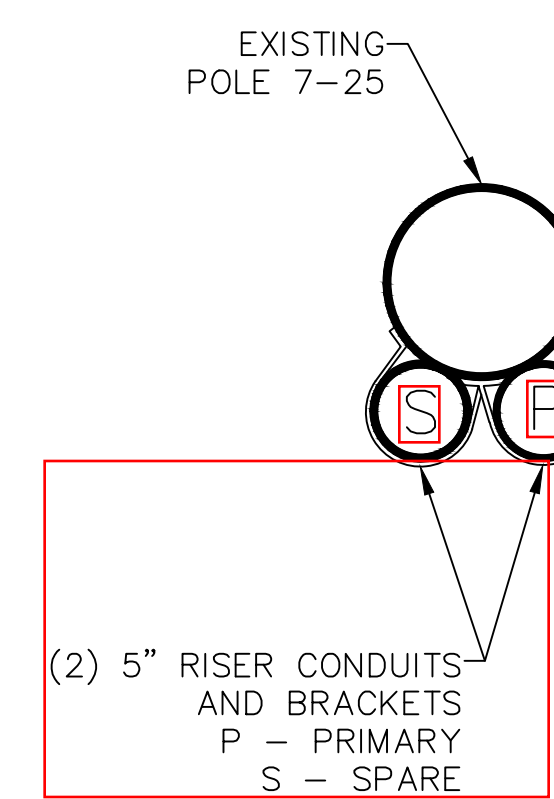

124 Grove St. Franklin, MA 02038		PROJECT NO: 270728				 MASSDOT DAMON RD LAYOUT PLAN	DESIGNED AS DRAWN CHECKED APPROVED	3/24/21 DATE NTS SCALE		DET-2	REV.
REV	DESCRIPTION	DATE	DES	CHK	APP					REVIEW 1	REVIEW 2

#48 DAMON RD

18D-035-001

OWNER: KERRYMAN PARTNERSHIP

P.O. BOX 60266, FLORENCE MA 01062

PATCH EAST OF LANE PLANT ROAD

18D-057-001

OWNER: CITY OF NORTHAMPTON

210 MAIN ST, NORTHAMPTON MA 01060

#55 DAMON RD

18D-065-001

OWNER: ROBERT S. THOMAS

55 DAMON RD, NORTHAMPTON MA 01060

#137 DAMON RD

18D-005-001

OWNER: EASTHAMPTON MAHADEV LLC

8 KINSBERRY WAY, EASTHAMPTON MA 01027



CITY OF NORTHAMPTON, MASSACHUSETTS
DEPARTMENT OF PUBLIC WORKS
125 Locust Street
Northampton, MA 01060

413-587-1570
Fax 413-587-1576

Donna LaScaleia
Director

Memorandum

To: Donna LaScaleia, Director of Public Works

From: David Veleta, City Engineer

Date: April 27, 2021

Re: Council Order 21.238 – Petition for Joint Ownership Pole Install No. 23303524 – Damon Road Reconstruction Project MassDOT No. 608236 – Damon Road

Approved 4-27-21 M

I have reviewed Department of Public Works (DPW) records and submittals including images, sketches and reconstruction plans for MassDOT Damon Road project No. 608236. This petition includes the proposed installation of one (1) joint ownership (JO) pole shared between National Grid and Verizon, referenced in City Council Order 21.238.

One (1) pole on Damon Road, numbered 9-50, is proposed. This pole is to be located at a point approximately 154 easterly of the intersection of River Run and Damon Road as shown in the application sketch and provides intermediate support for overhead wires spanning between existing poles.

The proposed pole is located within the existing roadway pavement and shall not be placed until the new, relocated curbing associated with the project is installed. The pole shall be placed with a minimum 1.5' horizontal offset between the face of the new curb and the face of the pole. A minimum 3' clearance between the back of the pole and the back of the new sidewalk is necessary to meet minimum ADA compliance. The sketch shows a proposed guy wire to the north, which must not interfere with the required ADA sidewalk clearance. The pole shall be placed with a minimum five-foot horizontal offset from the existing water service line for 104 Damon Road.

A valid trench permit approved by the DPW is required before work at this location commences.

nationalgrid

March 23, 2021

The City Council of Northampton, Massachusetts

To Whom It May Concern:

Enclosed please find a petition of NATIONAL GRID and VERIZON, covering joint NATIONAL GRID-VERIZON pole location(s)

If you have any questions regarding this permit, please contact:

Daniel Lopez-Velez 774-235-2603

Please notify National Grid's **Lisa Ayres** of the hearing date / time.

If this petition meets with your approval, please return an executed copy to each of the above-named Companies.

National Grid: Lisa Ayres; 1101 Turnpike Street; North Andover, MA 01845
978-725-1418

Very truly yours,

Jim Kehrer/lla

Jim Kehrer
Supervisor, Distribution Design

Enclosures

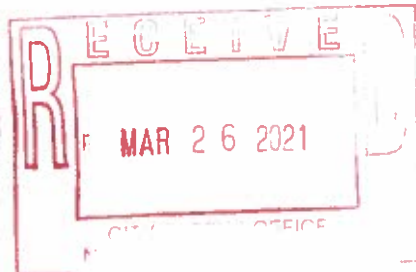

Questions contact - Daniel Lopez-Velez 774-235-2603
PETITION FOR JOINT OR IDENTICAL POLE LOCATIONS

North Andover, Massachusetts

To the City Council
Of Northampton, Massachusetts

Massachusetts Electric Company d/b/a NATIONAL GRID and Verizon New England, Inc. requests permission to locate poles, wires, and fixtures, including the necessary sustaining and protecting fixtures, along and across the following public way:

Damon Rd. - National Grid to install (1) JO pole 9-50 on Damon Rd. beginning at a point approximately 26 feet southeast of the centerline of the intersection of River Run and Damon Rd. and continuing approximately 154 feet in an east direction.

Location approximately as shown on plan attached.

Wherefore it prays that after due notice and hearing as provided by law, it be granted a location for and permission to erect and maintain poles and wires, together with such sustaining and protecting fixtures as it may find necessary, said poles to be erected substantially in accordance with the plan filed herewith marked – Damon Rd. - Northampton, Massachusetts.

23303524

Also, for permission to lay and maintain underground laterals, cables, and wires in the above or intersecting public ways for the purpose of making connections with such poles and buildings as each of said petitioners may desire for distributing purposes.

Your petitioner agrees to reserve space for one cross-arm at a suitable point on each of said poles for the fire, police, telephone, and telegraph signal wires belonging to the municipality and used by it exclusively for municipal purposes.

Massachusetts Electric Company d/b/a
NATIONAL GRID *Jim Kehrer/lla*
BY _____
Engineering Department

VERIZON NEW ENGLAND, INC.
BY *Albert F. Bessette*
Manager / Right of Way

Dated: March 19, 2021

Damon Rd. - Pole 9-50

Questions contact – Daniel Lopez-Velez 774-235-2603

ORDER FOR JOINT OR IDENTICAL POLE LOCATIONS

To the City Council - Northampton, Massachusetts

Notice having been given and public hearing held, as provided by law,
IT IS HEREBY ORDERED:

that Massachusetts Electric Company d/b/a NATIONAL GRID and VERIZON NEW ENGLAND INC. (formerly known as NEW ENGLAND TELEPHONE AND TELEGRAPH COMPANY) be and they are hereby granted joint or identical locations for and permission to erect and maintain poles and wires to be placed thereon, together with such sustaining and protecting fixtures as said Companies may deem necessary, in the public way or ways hereinafter referred to, as requested in petition of said Companies dated the 19th day of March 2021.

All construction under this order shall be in accordance with the following conditions:

Poles shall be of sound timber, and reasonable straight, and shall be set substantially at the points indicated upon the plan marked – Damon Rd. - Northampton, Massachusetts.

23303524 Filed with this order:

There may be attached to said poles by Massachusetts Electric Company d/b/a NATIONAL GRID and Verizon New England Inc. such wires, cables, and fixtures as needed in their business and all of said wires and cables shall be placed at a height of not less than twenty (20) feet from the ground.

The following are the public ways or part of ways along which the poles above referred to may be erected, and the number of poles which may be erected thereon under this order:

Damon Rd. - National Grid to install (1) JO pole 9-50 on Damon Rd. beginning at a point approximately 26 feet southeast of the centerline of the intersection of River Run and Damon Rd. and continuing approximately 154 feet in an east direction.

Also, for permission to lay and maintain underground laterals, cables, and wires in the above or intersecting public ways for the purpose of making connections with such poles and buildings as each of said petitioners may desire for distributing purposes.

I hereby certify that the foregoing order was adopted at a meeting of the
Of the City/Town of _____, Massachusetts held on the _____ day of _____ 20 .

Massachusetts

City/Town Clerk.
20 .

Damon Rd. - Pole 9-50

Received and entered in the records of location orders of the City/Town of
Book _____ Page _____

Attest:
City/Town Clerk

I hereby certify that on _____ 20____, at _____ o'clock, M
At _____ a public hearing was held on the petition of
Massachusetts Electric Company d/b/a NATIONAL GRID and VERIZON NEW ENGLAND,
INC. for permission to erect the poles, wires, and fixtures described in the order herewith recorded,
and that we mailed at least seven days before said hearing a written notice of the time and place of
said hearing to each of the owners of real estate (as determined by the last preceding assessment
for taxation) along the ways or parts of ways upon which the Company is permitted to erect
Poles, wires, and fixtures under said order. And that thereupon said order was duly adopted.

City/Town Clerk.

.....
.....
.....
.....

Board or Council of Town or City, Massachusetts

CERTIFICATE

I hereby certify that the foregoing is a true copy of the location order and certificate of
hearing with notice adopted by the _____ of the City of
Massachusetts, on the _____ day of 20____ and recorded with the records of location orders
of the said City, Book _____, and Page _____. This certified copy is made under the
provisions of Chapter 166 of General Laws and any additions thereto or amendments thereof.

Attest:
City/Town Clerk

JO POLES

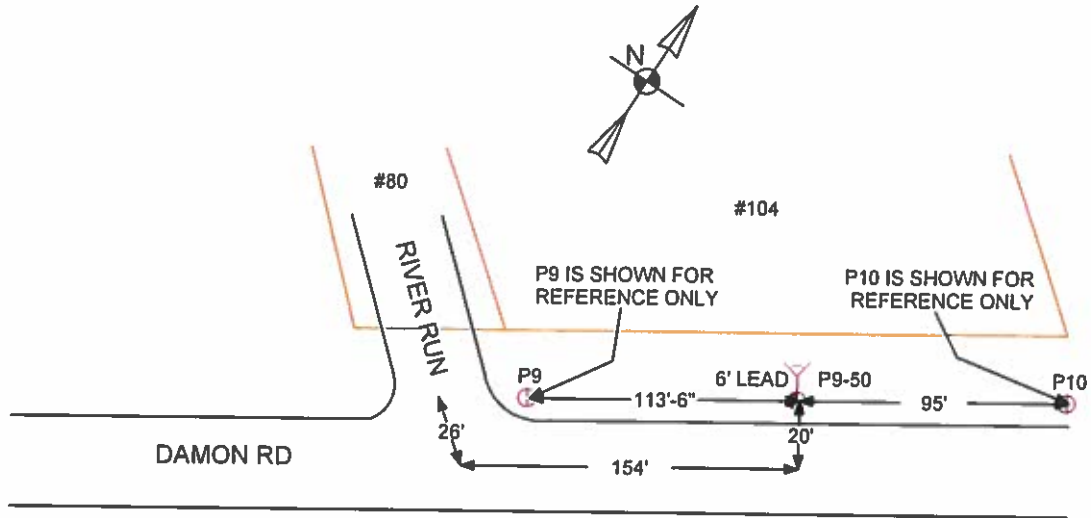

DANIEL LOPEZ
 TRC
 774-235-2603

JOINT OWNED POLE PETITION	nationalgrid And Verizon New England, Inc.
<input checked="" type="radio"/> Proposed NGRID Pole Locations	Date: 3/15/2021
<input type="radio"/> Existing NGRID Pole Locations	Plan Number: WR# 23303524
<input checked="" type="radio"/> Proposed J.O. Pole Locations	To Accompany Petition Dated: 3/15/2021
<input type="radio"/> Existing J.O. Pole Locations	To The: City Of Northampton
<input checked="" type="radio"/> Existing Telephone Co. Pole Locations	For Proposed: JO Pole: P9-50 Location: Damon Rd
<input type="radio"/> Existing NGRID Pole Location To Be Made J.O.	Date Of Original Grant: N/A
<input checked="" type="checkbox"/> Existing Pole Locations To Be Removed	
DISTANCES ARE APPROXIMATE	

JO POLES

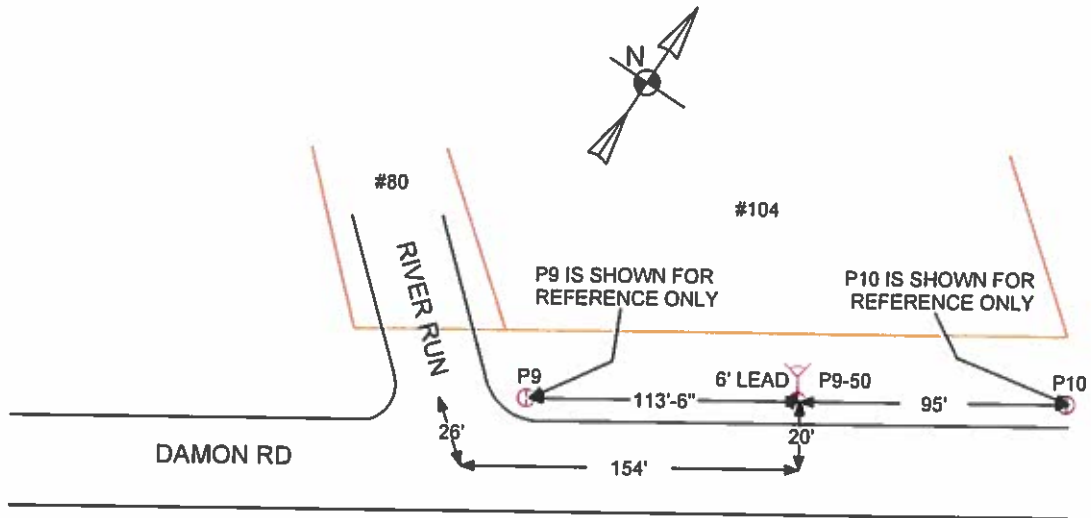

DANIEL LOPEZ
 TRC
 774-235-2603

JOINT OWNED POLE PETITION	nationalgrid And Verizon New England, Inc.
<input checked="" type="checkbox"/> Proposed NGRID Pole Locations	Date: 3/15/2021
<input type="checkbox"/> Existing NGRID Pole Locations	Plan Number: WR# 23303524
<input checked="" type="checkbox"/> Proposed J.O. Pole Locations	To Accompany Petition Dated: 3/15/2021
<input type="checkbox"/> Existing J.O. Pole Locations	To The: City Of Northampton
<input checked="" type="checkbox"/> Existing Telephone Co. Pole Locations	For Proposed: JO Pole: P9-50 Location: Damon Rd
<input type="checkbox"/> Existing NGRID Pole Location To Be Made J.O.	Date Of Original Grant: N/A
<input checked="" type="checkbox"/> Existing Pole Locations To Be Removed	
DISTANCES ARE APPROXIMATE	

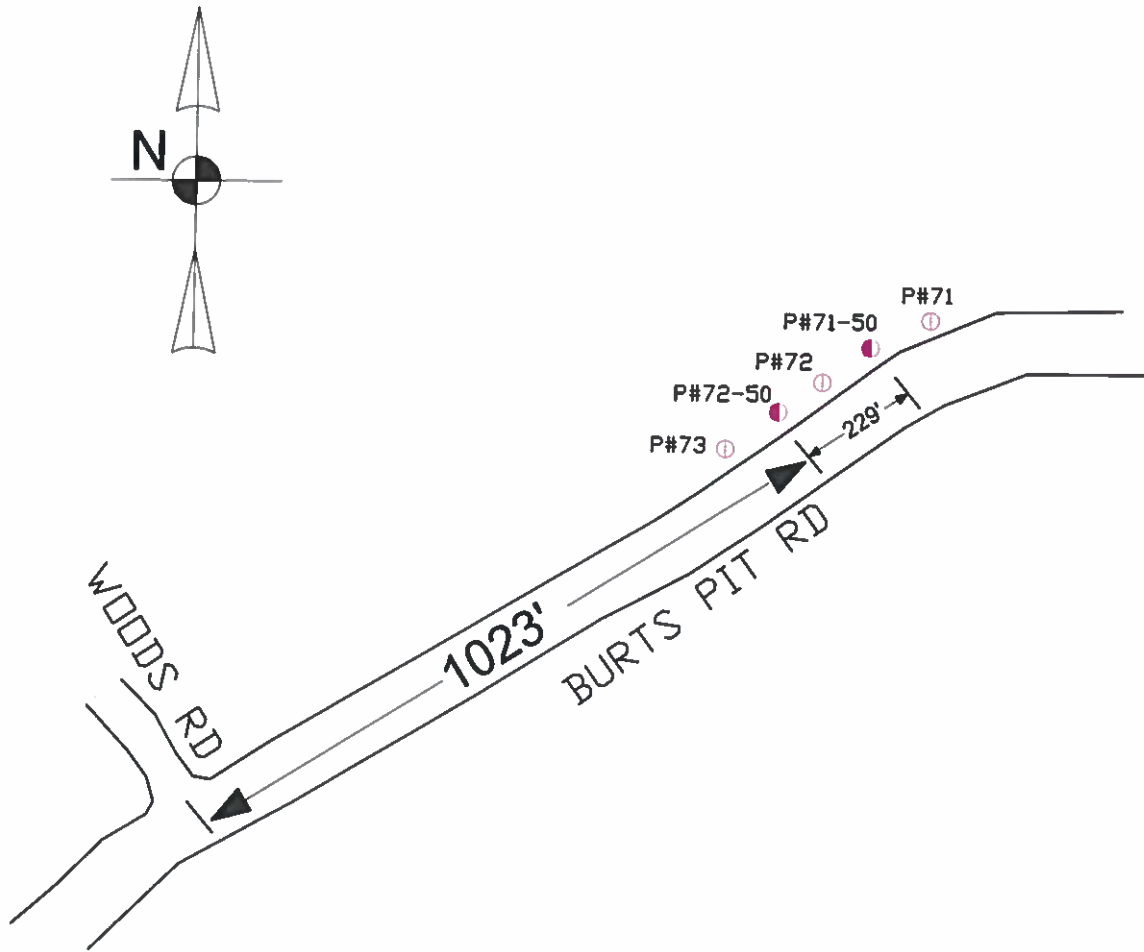

POLE PETITION

nationalgrid

- Proposed NGRID Pole Locations
- Existing NGRID Pole Locations
- Ⓜ Proposed J.O. Pole Locations
- Ⓜ Existing J.O. Pole Locations
- Ⓜ Existing Telephone Co. Pole Locations
- Ⓜ Existing NGRID Pole Location To Be Made J.O.
- Ⓜ Existing Pole Locations To Be Removed

Date: 2-5-21

Plan Number: WR#30025210

To Accompany Petition Dated:

To The: TOWN Of NORTHAMPTON

For Proposed: 2 Pole: JO Location: BURTS PIT RD

Date Of Original Grant:

DISTANCES ARE APPROXIMATE



CITY OF NORTHAMPTON, MASSACHUSETTS
DEPARTMENT OF PUBLIC WORKS
125 Locust Street
Northampton, MA 01060

413-587-1570
Fax 413-587-1576

Donna LaScaleia
Director

Memorandum

To: Donna LaScaleia, DPW Director *Approved 4-27-21* 
From: Kris Baker, P.E., Civil Engineer
Date: April 26, 2021
Re: Petition for Joint or Identical Pole Locations No. 30025210

National Grid is proposing to install two (2) Jointly Owned Poles on Burts Pit Road: one approximately 1,023 feet east from the centerline of the intersection with Woods Road, and one approximately 229 feet east from that pole, as staked. A site visit was conducted on April 26, 2021 with the developer and a National Grid representative to discuss the proposed work as well as to determine the field location of the proposed poles in relation to the existing water and sewer stubs to the properties. The existing water valves and sewer cleanouts were field located and marked by the Water Division and the Sewer & Drain Division, respectively.

The proposed location of pole #72-50 is six (6) feet from the existing water service line. The proposed location of pole #71-50 is five (5) feet from the existing water service line. The poles are located more than five (5) feet from existing sewer service lines and more than ten (10) feet from the existing water main, drain pipes, sewer main, and manhole structures. The poles should therefore be set at the staked locations and there will be no utility conflicts.

There are no trees in the vicinity of the proposed poles and no apparent interference of trees with proposed overhead wires.

A valid "Excavation/Trench Permit" issued by the DPW is required prior to construction.



City of Northampton
MASSACHUSETTS

In the City Council, May 6, 2021

Upon the Recommendation of: Councilor Karen Foster
 Councilor Marianne LaBarge
 Councilor Rachel Maiore
 Councilor Gina-Louise Sciarra

R-21.266 A RESOLUTION IN SUPPORT OF WORKERS OF THE HAMPSHIRE GAZETTE

WHEREAS: the *Daily Hampshire Gazette* has been an institution in our community for nearly 235 years; and

WHEREAS: the *Gazette* has tirelessly chronicled the triumphs, tragedies and history of the people of the Connecticut River Valley, keeping the public informed and proving itself invaluable in exposing injustice in Northampton and beyond; and

WHEREAS: local news is critical to a working democracy, ensuring communities have accurate information, uplifting marginalized voices, and providing crucial oversight over local governance; and

WHEREAS: Northampton's municipal government relies on the *Gazette* to communicate issues, events, projects and public notices to the public; and

WHEREAS: the *Gazette* is made by its workers and this Council appreciates how they have persevered through a global pandemic, despite losing over half their staff, to keep the Valley informed of vital information, and in the early stages of the pandemic making the important decision to provide coronavirus-related news to our community at no charge to readers; and

WHEREAS: the *Gazette's* unionized workers have been in contract negotiations with the *Gazette's* parent company, Newspapers of New England, for nearly two years; and

WHEREAS: the *Gazette's* workers deserve protections against the outsourcing of their work as well as a contract that provides for a fair wage with cost of living increases and remains intact no matter who owns the newspaper; and

WHEREAS: the *Gazette's* workers who were laid-off deserve the opportunity to be rehired if their positions return to the paper;

NOW, THEREFORE BE IT RESOLVED, that the Northampton City Council stands in solidarity with the workers of the *Daily Hampshire Gazette*, and asks Newspapers of New England to swiftly bargain a contract that improves the well-being of its workers, which will strengthen the newspaper and help it continue for years to come. We call on Newspapers of New England to invest in the *Gazette* and its workers, and to make a commitment to local ownership;

BE IT FURTHER RESOLVED that the Northampton City Council recognizes the importance of the *Daily Hampshire Gazette* to our region, and encourages our local community to support the *Gazette* to help maintain the financial viability of this critical source of local news;

BE IT FURTHER RESOLVED that the Administrative Assistant to the City Council shall send a copy of this Resolution to U.S. Senators Elizabeth Warren and Ed Markey, U.S. Representative Jim McGovern, Senator Jo Comerford, Representative Lindsay Sabadosa, Newspaper of New England President and CEO Aaron Julien, *Daily Hampshire Gazette* Publisher Shawn Palmer, Editor-in-Chief Joan Livingston and the Pioneer Valley News Guild.

In the City Council, May 6, 2021

Upon the Recommendation of: Councilor Rachel Maiore and Councilor Michael J. Quinlan, Jr

R-21.267

**A Resolution In Support of the Recommendations of the
Northampton Policing Review Commission**

WHEREAS, the Mayor and City Council of Northampton committed to “actions at the local level to combat public health crisis of systemic racism” by creating the Northampton Policing Review Commission and charging the Commission to study these complex issues and recommend reforms to the current organizational and oversight structures, municipal funding allocations, and policies and ordinances that together can transform how the city delivers policing services while ensuring community safety equitably and justly for all, and

WHEREAS, The Northampton Policing Review Commission met that charge through dedicated work, holding three public hearings, more than 70 meetings of the full commission and sub-committees, and countless hours of research, and

WHEREAS, The Northampton Policing Review Commission’s final report underscored the importance of building a new system that reflects Northampton’s values and is designed to promote the care, health, and well-being of everyone in our community at no one’s expense.

WHEREAS, The Northampton Policing Reviewing Commission in the Reimaging Safety report states, “the Department of Community Care be established and funded in FY 2022 and fully operational in FY 2023,” and

WHEREAS, The Northampton Policing Reviewing Commission in the Reimaging Safety report states, “the Commission recommends that this department be intentionally independent from the Northampton Police Department, but open to collaboration with all City departments. Given the nature of the responsibilities we are recommending this department take on, and the recognition of racism itself as a health crisis, we advocate that the department be situated underneath the Board of Health,”

NOW, THEREFORE BE IT RESOLVED, that the Northampton City Council supports the recommendations outlined in the Final Report of the Northampton Policing Review Commission.

BE IT FURTHER RESOLVED, that the Northampton City Council commends the members of the Northampton Policing Review Commission for their effort and dedication to Northampton.

BE IT FURTHER RESOLVED, that the Northampton City Council urges the Mayor to establish a Department of Community Care in this fiscal year and fund it by at least \$882,602 in the FY22 Budget.

BE IT FURTHER RESOLVED, that the City Council recommends that given the nature of the responsibilities that are recommended for this department to take on, and the recognition of racism itself as a health crisis, we advocate that the department be situated underneath the Board of Health.

BE IT FURTHER RESOLVED, that the Administrative Assistant to the City Council shall send a copy of this Resolution to Mayor David Narkewicz, Health Director Merridith O'Leary and The Commissioners of the Northampton Policing Review Commission.

City of Northampton

AFFIDAVIT OF WAGE COMPLIANCE

Name of Business: Cancer Connection Thrift Shop

Location of Business: 375 South Street

The Northampton City Council, in determining whether to issue, re-issue, modify, suspend or revoke a license. under G.L. c. 140, shall require that a potential or current licensee certify that they are not subject to a federal or state criminal or civil judgment, administrative citation, order or final administrative determination resulting from a violation of G.L. c. 149, c. 151, or the Fair Labor Standards Act. The City Council may require a wage bond or insurance be posted by any potential licensee who does not certify that they are not subject to a federal or state criminal or civil judgment, administrative citation, order or final administrative determination resulting from a violation of G.L. c. 149, c. 151, or the Fair Labor Standards Act. Licensees that are subject to a state or federal debarment for violation of the above laws, either voluntarily or involuntarily, or that have been prohibited from contracting with the Commonwealth or any of its agencies or subdivisions shall be prohibited from holding, or continuing to hold, licenses issued under G.L. c. 140, for the entire period of debarment or other stated time period.

Applicants must check box 1 or box 2 as applicable and must sign this Form, certifying compliance with the requirements set out in this Form. This Form must be included with the application.

AFFIDAVIT: (Choose 1 below)

This License applicant is not subject to a federal or state criminal or civil judgment, administrative citation, order or final administrative determination resulting from a violation of G.L. c. 149, c. 151, or the Fair Labor Standards Act within the last three years.

This License applicant is subject to a federal or state criminal or civil judgment, administrative citation, order or final administrative determination resulting from a violation of G.L. c. 149, c. 151, or the Fair Labor Standards Act within the last three years. This applicant will provide a wage bond or wage insurance for the period of the license.

Christine Quinn

(Typed or printed name of applicant)

Christine Quinn

(Signature)

City of Northampton
Application for Annual License

NORTHAMPTON, MASS., _____

To the Honorable City Council of the City of Northampton:

The undersigned respectfully petitions your honorable body for a License as follows:

Name of Business: **Cancer Connection Thrift Shop**

Type of License: **Secondhand Dealer**

Location of Business: **375 South Street**

Print Name of Applicant: (V) Christine Quinn

Signature of Applicant: (V) Christine Quinn

Address of Applicant: (V) No. 20 Street Zabek Dr. Easthampton MA
01027

In City Council, _____

Referred to Committee on Licenses.

ATTEST:

City Clerk

In Committee on Licenses, _____

Voted to recommend that Petition ___ be
granted, _____ not granted

ATTEST:

Clerk

In City Council, _____ (date)

Voted that Petition be _____ granted
_____ not granted

Attest: _____ Clerk to City Council

City of Northampton

STATEMENT OF ALL TAXES FILED AND PAID

Name of Business: Cancer Connection Thrift Shop

Location of Business: 375 South Street

The license (as a/for a) Secondhand Dealer will not be issued unless this certification clause is signed by the applicant listed on the license.

I, Christine Quinn (print name of owner or authorized agent of the business) certify under the penalties of perjury that I, to my best knowledge and belief, have filed all state tax returns and paid all state taxes as required under law.

Christine Quinn

Signature of Owner or Agent

_____ or 

Social Security Number

Federal Identification Number

Your social security number will be furnished to the Massachusetts Department of Revenue to determine whether you have met tax filing or tax payment obligations. Licenses who fail to correct their non-filing or delinquency will be subject to license suspension or revocation. This request is made under the authority of Massachusetts General Law, chapter 62C, section 49A.

City of Northampton
Treasurer/Collector's Office
Permit Denial Form

Revised 11-30-2018

REQUESTED BY: **Pamela L. Powers, City Clerk**

Name of Person, Corporation or Business: **Cancer Connection Thrift Shop**

Location of Property, Service or Address: **375 South Street, Northampton, MA 01060**

All permits denied for outstanding amounts must receive confirmation of good standing from the Treasurer/Collector's Office PRIOR to issuance of the permit.

For Tax Collector's/Treasurer's Office Use Only

Please list below any tax, assessed to your office that is unpaid for twelve (12) months or more after its due date, unless there is a pending abatement or appeal before the Appellate Tax Board, for the person, corporation, or business entity noted above.

This is a tax exempt entity for FY21 and no amounts are outstanding

Signed: Kristine Bissell

Dated: April 7, 2021

Adopted 5-21 1992 [Ch14 S.14-21 of the 1977 Code]
Denial/Revocation of License

City of Northampton

THANK YOU!
CITY CLERK
NORTHAMPTON
210 MAIN ST, ROOM 4
(413) 587-1224

City of Northampton
Application for Annual License

04-27-2021 15:55
REG 000013

BUSINESS CRT \$50.00
PED/TAXI CAB \$25.00
PED/TAXI CAB \$25.00
PED/TAXI CAB \$25.00
PED/TAXI CAB \$25.00
PED/TAXI CAB \$25.00
PED/TAXI CAB \$25.00
PED/TAXI CAB \$25.00
PED/TAXI CAB \$25.00
PED/TAXI DRI \$25.00
PED/TAXI DRI \$25.00
PED/TAXI DRI \$25.00
PED/TAXI DRI \$25.00
PED/TAXI DRI \$25.00
PED/TAXI DRI \$25.00
CHECK \$425.00

NORTHAMPTON, MASS., 4/20/21

v Council of the City of Northampton:

respectfully petitions your honorable body for a License as follows:

Business: Cosmic Cab

Type of License: Taxi Cab - 7

Address of Business: 23 Hooker Avenue

Print Name of Applicant: (v) Jeffrey Miller

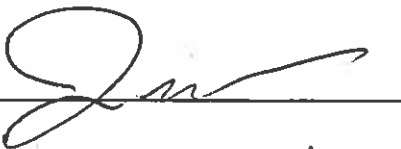
Signature of Applicant: (v) 

Address of Applicant: (v) No. 241 Street Haydenville Rd.

In City Council, _____

Referred to Committee on Licenses.

ATTEST:

City Clerk

In Committee on Licenses, _____

Voted to recommend that Petition ___ be granted, _____ not granted

ATTEST:

Clerk

In City Council, _____ (date)

Voted that Petition be _____ granted
_____ not granted

Attest: _____ Clerk to City Council



City of Northampton

Application for Vehicle Registration - Vehicle for Hire

PRINT ALL INFORMATION (except signature)

(Check one)

Taxi Vehicle

Livery Vehicle

Today's Date: 4/20/21

Name (First, Middle, Last) Jeffrey David Miller

Residential Address 241 Haydenville Rd. Leeds MA 01053
Number Street City/Town State Zip Code

Business Address 160 Main St. Northampton MA 01060
Number Street City/Town State Zip Code

Mailing Address _____
Number Street City/Town State Zip Code

Telephone Number 413-230-6119

Vehicle Information

Make Dodge

Model Grand Caravan

Year 2008

Color Gray

Registration Number TA 11GF

Vehicle Id Number 2D8HN44HX8R772469

Seating Capacity (exclusive of operator) 6

Number of Seat belts 7

Attach the following: Insurance Policy for this vehicle; child safety seat plan; copy of vehicle inspection; color photo of vehicle

*Liability Limits: \$100,000 / \$300,000 injury or death; \$50,000 property damage
Policy must show that the policy shall not be cancelled without giving the City clerk 10 days notice thereof.*

Sworn to this 20th day of April, 2021, before me.

Pamela L. Prouf
City Clerk

FOR LICENSING AUTHORITY USE

In City Council, _____, voted that this petition is _____ is not _____ granted.

Attest: _____
Clerk to the City Council



CERTIFICATE OF REGISTRATION

M.G.L. Chapter 90 Section 24B makes it a crime to alter this Certificate
MASSACHUSETTS DEPARTMENT OF TRANSPORTATION

24

EXTERNAL CODE TAN		REGISTRATION TYPE Taxi Normal		PLATE NUMBER 11GF	EFFECTIVE DATE 20-Apr-2021	TITLE NUMBER	EXPIRES ON 30-Nov-2021
MODEL YEAR 2008	MAKE DODG	MODEL GRAND CARAVAN	MODEL NUMBER	BODY STYLE VAN	COLOR GRAY	VEHICLE IDENTIFICATION NUMBER 2D8HN44HX8R772469	
RESIDENTIAL ADDRESS (IF DIFFERENT THAN MAILING)						TOTAL REGISTERED WEIGHT FOR A COMMERCIAL VEHICLE OR TRAILER	
GARAGE ADDRESS 160 MAIN ST STE 8 NORTHAMPTON MA 01060-3187						US DOT NUMBER FOR COMMERCIAL VEHICLE	
NAME(S) OF OWNER(S) AND MAILING ADDRESS JEFFREY D MILLER 160 MAIN ST STE 8 NORTHAMPTON MA 01060-3187						INSURANCE COMPANY ARBELLA PROTECTION INSURANCE COMPANY	
LESSEE/IN CUSTODY OF						MAXIMUM SEATING CAPACITY FOR VEHICLES FOR HIRE	
						<i>James J. Jeter</i> Registrar of Motor Vehicles	

SPECIAL MESSAGE If this vehicle is newly acquired, it must be inspected within 7 days of registration.	CHANGE OF ADDRESS <input type="checkbox"/> RESIDENTIAL <input type="checkbox"/> MAILING <input type="checkbox"/> GARAGE
--	--

CERTIFICATE OF REGISTRATION
 M.G.L. Chapter 90 Section 24B makes it a crime to alter this Certificate
 MASSACHUSETTS DEPARTMENT OF TRANSPORTATION

Important information for vehicle owners

- **Certificate of Registration:** Every person operating a motor vehicle shall have the Certificate of Registration for the motor vehicle and/or trailer, in the vehicle, in some easily accessible place. The records of the RMV constitute the official status of the vehicle registration.
- **Change of Address:** By law, you must report any change of address to the RMV within 30 days. Visit mass.gov/rmv to change your address. Once you have reported the address change to the RMV, please write corrected address in box provided above.
- **No Insurance Card Required:** Massachusetts law does not require an insurance card. M.G.L. Chapter 90, Section 34, and Chapter 175, Section 113A, requires the vehicle's owner to maintain a compulsory motor vehicle liability insurance policy or bond for bodily injury coverage and property damage insurance. The insurer is required by law to electronically notify the Registry of Motor Vehicles if coverage lapses. The vehicle owner is then notified by the RMV to obtain new insurance within 10 days or the registration will be revoked. Bonds are filed with the State Treasurer's Office.
- **Transferring Your Plates:** Massachusetts General Law (M.G.L. Chapter 90, Section 2) allows you to transfer valid registration plates from this vehicle to a newly acquired new or used motor vehicle or trailer while you obtain insurance and a new registration. See the Transferring a Registration Section on the RMV's website at mass.gov/rmv for more information.
- **Cancel the registration plates if:**
 - The vehicle has been sold or junked and the registration is not going to be transferred to another vehicle.
 - You move to another state and you register the vehicle in that state.
 - The insurance policy is not renewed or is cancelled and there is no plan to obtain a new policy.

Every motor vehicle shall have the Certificate of Registration for the motor vehicle and/or trailer, in the vehicle, in some easily accessible place.
 Skip the Line, Go Online! Visit Mass.Gov/RMV for list of available transactions.

Change of address to the RMV within 30 days. Visit mass.gov/rmv to change your address. Once you have reported the address change to the RMV, please write corrected address in box provided above.

Massachusetts law does not require an insurance card. M.G.L. Chapter 90, Section 34, and Chapter 175, Section 113A, requires the vehicle's owner to maintain a compulsory motor vehicle liability insurance policy or bond for bodily injury coverage and property damage insurance. The insurer is required by law to electronically notify the Registry of Motor Vehicles if coverage lapses. The vehicle owner is then notified by the RMV to obtain new insurance within 10 days or the registration will be revoked. Bonds are filed with the State Treasurer's Office.



Vehicle Inspection Report

Please Review This Important Information

Your vehicle has **PASSED** both its **SAFETY TEST** and its **EMISSIONS TEST**. The results are summarized in this report.

Questions? Visit www.mass.gov/vehiclecheck or call Customer Service at 1-844-358-0135. Customer Service is staffed from 7 a.m. to 5 p.m. Monday, Wednesday, Friday, and Saturday, and from 7 a.m. to 8 p.m. on Tuesday and Thursday.

Overall Result:	PASS	Vehicle Information		Station Information	
Safety Result	PASS	VIN	2D8HN44HX8R772469	ERNE'S GARAGE INC	
Emissions Result	PASS	License Plate	11GF	72 KING STREET	
Start Test Date/Time	4/26/2021 9:50 AM	Plate Type/State	TAN / MA	NORTHAMPTON	MA
End Test Date/Time	4/26/2021 9:58 AM	Vehicle Type	PASSENGER	(413) 584-0716	
Test Type	Regular	Year / Make	2008 Dodge	Station Number	PB100149
Sticker Number	221003751	Model	Grand Caravan	Workstation Number	MAW00000648
Inspection Type	Initial	Fuel Type	GASOLINE	Inspector Number	*****5128
Inspection Counter	1	Engine Cyl / Size	6 / 3L		
		GVWR	7000		
		Odometer	113398		
				Inspection Fee	\$35.00

Safety Inspection Results

License Plate Mounting and Condition	PASS	Service Brakes	PASS	Parking Brake	PASS
Horn	PASS	Stop Lights and Tail Lights	PASS	Headlight Aim and Operation	PASS
Lighting Devices and Reflectors	PASS	Directional Signals and 4-Ways	PASS	Front End	PASS
Steering and Suspension	PASS	Frame	PASS	Windshield Wipers and Cleaner	PASS
Safety Belts	PASS	Air Bags	N/A	Muffler and Exhaust System	PASS
Window Tint	PASS	Windshield	PASS	Rear View Mirror	PASS
Bumpers/Fenders/Exterior Sheet Metal	PASS	Fuel Tank Filler Cap	PASS	Fuel Tank Filler Neck and Components	PASS
Visible Smoke	PASS	Altered Vehicle Height	PASS	Tires	PASS
Other	PASS				

Inspection Comments

None

On-Board Diagnostic (OBD) Results	OBD Readiness Monitor Results	OBD Additional Data			
Tampering Check	PASS	Catalyst	READY	Miles Since Code Clearing	330
Connector Result	PASS	Catalyst Heater	UNSUPPORTED	Warm-Ups Since Code Clearing	11
RPM Result	PASS	Evaporative System	READY	Pin 16 Voltage	14.1
Key-On Bulb Check	N/A	Secondary Air System	UNSUPPORTED	OBD Diagnostic Trouble Codes	
Engine-Running Bulb Check	N/A	A/C System	UNSUPPORTED		
Scan Tool Check	N/A	Oxygen Sensor	READY		
Communication Result	PASS	Oxygen Sensor Heater	READY		
MIL Status Result	PASS	EGR and/or VVT System	READY	OBD Permanent Fault Codes	
Readiness Result	PASS			7F 0A 80	

Scan to visit website



VIR Number



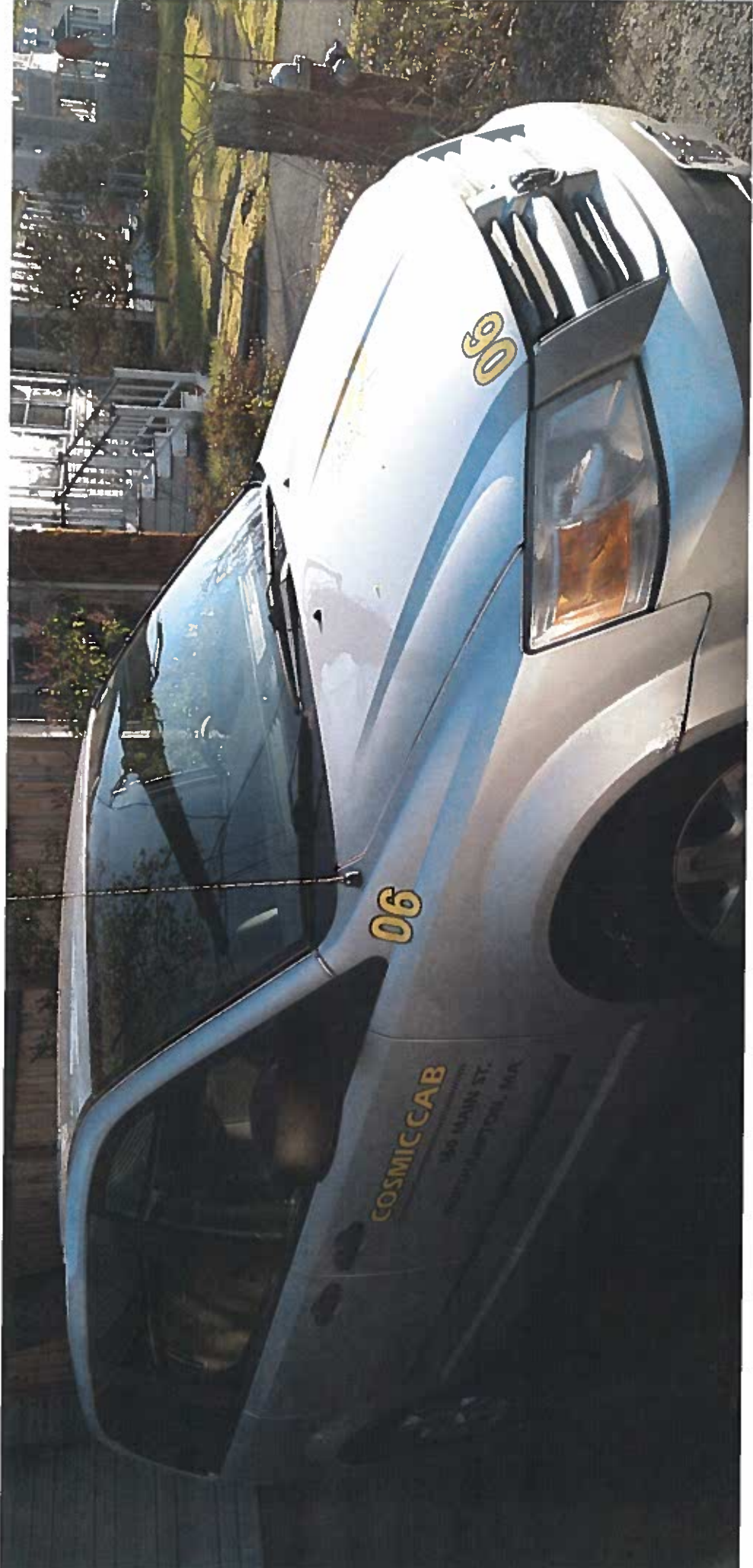

06

90

COSMICCAB
86 MAIN ST.
NEWTON, MA



COSMIC CAB (413) 230-6119

06

Massachusetts
11GF
TAXI

Dodge Journey

ARTIOLI



City of Northampton
Application for Vehicle Registration - Vehicle for Hire

PRINT ALL INFORMATION (except signature)

(Check one) [X] Taxi Vehicle [] Livery Vehicle Today's Date: 4/26/21

Name (First, Middle, Last) Jeffrey David Miller
Residential Address 241 Haysdenville Rd Leeds MA 01053
Business Address 160 Main St. STE 8 Northampton MA 01060
Mailing Address
Telephone Number 413-230-6119

Vehicle Information

Make Dodge Registration Number TA 26983
Model Magnum Vehicle Id Number 2D4G248VX5H511216
Year 2005 Seating Capacity 4
Color Gray Number of Seat belts 5

Attach the following: Insurance Policy for this vehicle; child safety seat plan; copy of vehicle inspection; color photo of vehicle

Liability Limits: \$100,000 / \$300,000 injury or death; \$50,000 property damage
Policy must show that the policy shall not be cancelled without giving the City clerk 10 days notice thereof.

Sworn to this 28th day of April, 2021, before me.

[Signature]
City Clerk

FOR LICENSING AUTHORITY USE

In City Council, _____, voted that this petition is _____
is not _____ granted.

Attest: _____
Clerk to the City Council



CERTIFICATE OF REGISTRATION

M.G.L. Chapter 90 section 24B makes it a crime to alter this certificate
MASSACHUSETTS DEPARTMENT OF TRANSPORTATION

Plate Type TAN	Registration Type TAXI NORMAL	Plate Number 26983	Effective Date 01-Dec-2020	Title Number BV096470	Expires On →	Month 11	Year 21
Model Year 2005	Make DODG	Model MGN	Body Style STWAG	Color(s) GRAY	Vehicle Identification Number 2D4GZ48VX5H511216		
Residential Address (If Different than Mailing)					Total Registered Weight for Commercial Vehicle or Trailer		
Garage Address 241 HAYDENVILLE RD LEEDS MA 010539768					US DOT Number for Commercial Vehicle		
Name(s) of Owner(s) and Mailing Address 003427 *****AUTO**5-DIGIT 01060 JEFFREY D MILLER 160 MAIN ST STE 8 NORTHAMPTON MA 01060-3187					Insurance Company ARBELLA PROTECTION INSURANCE COMPANY		
					Maximum Seating Capacity for Vehicles for Hire 5		
					Lessee/In Custody Of James J. Jelen		
Special Message					Change of Address <input type="checkbox"/> Residential <input type="checkbox"/> Mailing <input type="checkbox"/> Garage		

Information for Vehicle Owners

- Certificate of Registration:** Every person operating a motor vehicle shall have the Certificate of Registration for the motor vehicle and/or trailer, in the vehicle, in some easily accessible place. The records of the RMV constitute the official status of the vehicle registration.
- Change of Address:** By law, you must report any change of address to the RMV within 30 days. Visit Mass.Gov/RMV to change your address. Once you have reported the address change to the RMV, please write corrected address in box provided above.
- No Insurance Card Required:** Massachusetts law does not require an insurance card. M.G.L. Chapter 90, section 34, and Chapter 175, Section 113A, requires the vehicle's owner to maintain a compulsory motor vehicle liability insurance policy or bond for bodily injury coverage and property damage insurance. The insurer is required by law to electronically notify the Registry of Motor Vehicles if coverage lapses. The vehicle owner is then notified by the RMV to obtain new insurance within 10 days or the registration will be revoked. Bonds are filed with the State Treasurer's Office.
- Transferring Your Plates:** Massachusetts General Law (M.G.L. Chapter 90, Section 2) allows you to transfer valid registration plates from this vehicle to a newly acquired new or used motor vehicle or trailer while you obtain insurance and a new registration. See the Transferring a Registration Section on the RMV's website at www.mass.gov/rmv for more information.
- Cancel the registration plates if:**
 - The vehicle has been sold or junked and the registration is not going to be transferred to another vehicle.
 - You move to another state and you register the vehicle in that state.
 - The insurance policy is not renewed or is cancelled and there is no plan to obtain a new policy.



212-066395

Skip the Line, Go Online! Visit Mass.Gov/RMV for list of available transactions.



Vehicle Inspection Report

Please Review This Important Information

Your vehicle has **PASSED** its **SAFETY TEST**. The results are summarized in this report.

Questions? Visit www.mass.gov/vehiclecheck or call Customer Service at 1-844-358-0135. Customer Service is staffed from 7 a.m. to 5 p.m. Monday, Wednesday, Friday, and Saturday, and from 7 a.m. to 8 p.m. on Tuesday and Thursday.

Overall Result: PASS		Vehicle Information		Station Information	
Safety Result	PASS	VIN	2D4GZ48VX5H511216	ERNIES GARAGE, LLC	
Emissions Result	N/A	License Plate	TA26983	72 KING STREET	
Start Test Date/Time	5/6/2020 8:48 AM	Plate Type/State	TAN / MA	NORTHAMPTON	MA
End Test Date/Time	5/6/2020 8:56 AM	Vehicle Type	PASSENGER	(413) 584-0716	
Test Type	Regular	Year / Make	2005 Dodge	Station Number	PB005056
Sticker Number	210718353	Model	Magnum	Workstation Number	MAW00000648
Inspection Type	Initial	Fuel Type	GASOLINE	Inspector Number	*****0933
Inspection Counter	1	Engine Cyl / Size	6 / 3.5L		
		GVWR	6000		
		Odometer	226736		

Inspection Fee \$35.00

Safety Inspection Results

License Plate Mounting and Condition	PASS	Service Brakes	PASS	Parking Brake	PASS
Horn	PASS	Stop Lights and Tail Lights	PASS	Headlight Aim and Operation	PASS
Lighting Devices and Reflectors	PASS	Directional Signals and 4-Ways	PASS	Front End	PASS
Steering and Suspension	PASS	Frame	PASS	Windshield Wipers and Cleaner	PASS
Safety Belts	PASS	Air Bags	N/A	Muffler and Exhaust System	PASS
Window Tint	PASS	Windshield	PASS	Rear View Mirror	PASS
Bumpers/Fenders/Exterior Sheet Metal	PASS	Fuel Tank Filler Cap	PASS	Fuel Tank Filler Neck and Components	PASS
Visible Smoke	PASS	Altered Vehicle Height	PASS	Tires	PASS
Other	PASS				

Inspection Comments

None

VIR Number



Scan to visit website

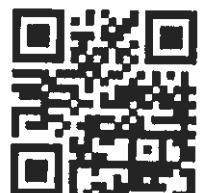



COSMIC CAB (413) 230-6119

04

Massachusetts 21
26983
TAXI

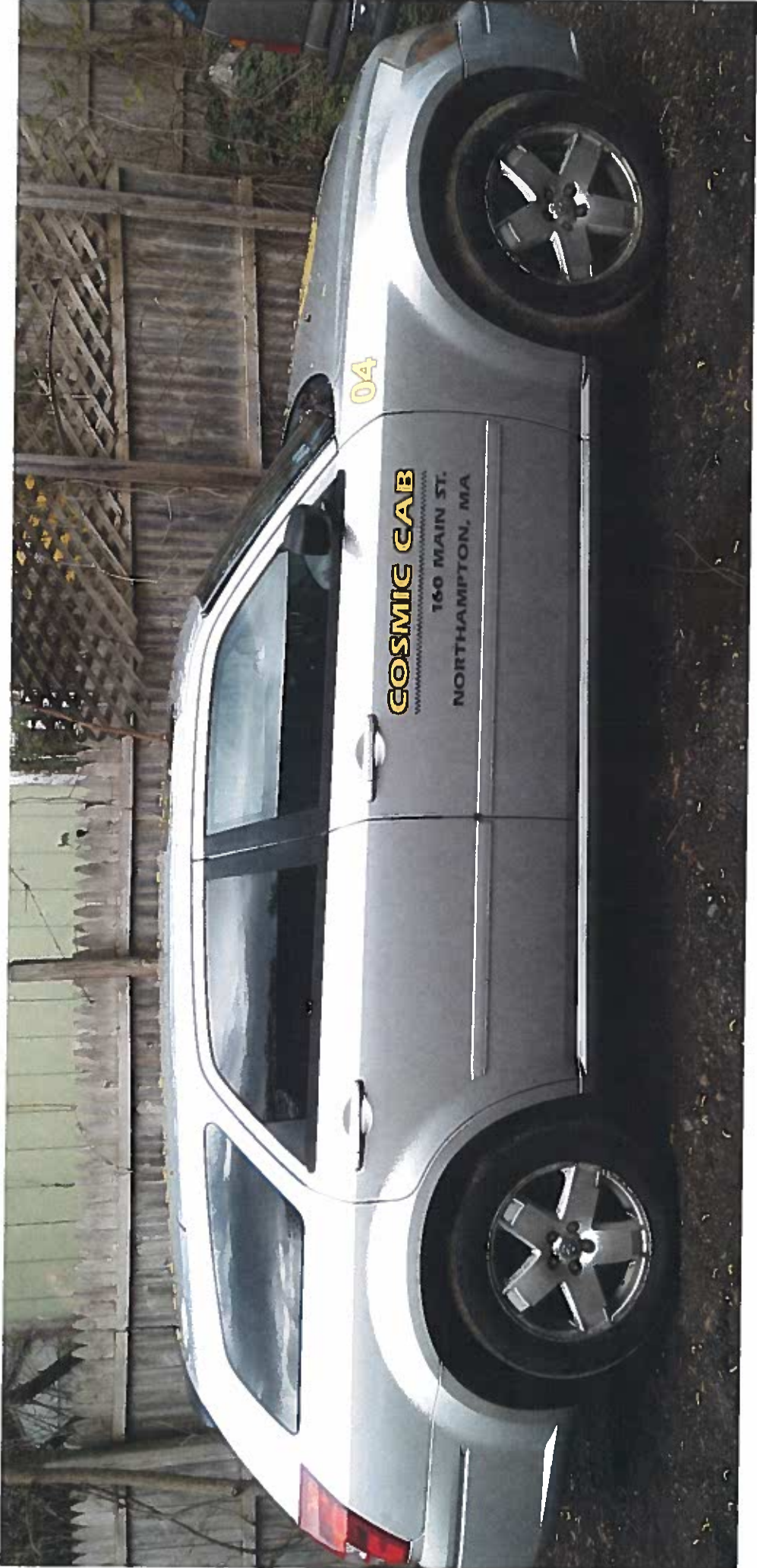

04

GOSMIC CAB

160 MAIN ST.
NORTHAMPTON, MA



City of Northampton Application for Vehicle Registration - Vehicle for Hire

PRINT ALL INFORMATION (except signature)

(Check one)

Taxi Vehicle

Livery Vehicle

Today's Date: 4/20/21

Name (First, Middle, Last) Jeffrey David Miller

Residential Address 241 Haydenville Rd. Leeds MA 01053
Number Street City/Town State Zip Code

Business Address 160 Main St. Northampton MA 01060
Number Street City/Town State Zip Code

Mailing Address _____
Number Street City/Town State Zip Code

Telephone Number 413-230-6119

Vehicle Information

Make Dodge

Model Grand Caravan

Year 2008

Color Brown

Registration Number TA 629 D

Vehicle Id Number 1D8HN44H1B B154 670

Seating Capacity (exclusive of operator) 6

Number of Seat belts 7

Attach the following: Insurance Policy for this vehicle; child safety seat plan; copy of vehicle inspection; color photo of vehicle

*Liability Limits: \$100,000 / \$300,000 injury or death; \$50,000 property damage
Policy must show that the policy shall not be cancelled without giving the City clerk 10 days notice thereof.*

Sworn to this 20th day of April, 2021, before me.

Pamela L. Powell
City Clerk

FOR LICENSING AUTHORITY USE

In City Council, _____, voted that this petition is _____ is not _____ granted.

Attest: _____
Clerk to the City Council



CERTIFICATE OF REGISTRATION

M.G.L. Chapter 90 section 24B makes it a crime to alter this certificate

MASSACHUSETTS DEPARTMENT OF TRANSPORTATION

Plate Type TAN	Registration Type TAXI NORMAL	Plate Number 629D	Effective Date 01-Dec-2020	Title Number BT474639	Expires On →	Month 11	Year 21
Model Year 2008	Make DODG	Model CARAVA	Body Style VAN	Color(s) BROWN	Vehicle Identification Number 1D8HN44H18B184670		
Residential Address (If Different than Mailing)					Total Registered Weight for Commercial Vehicle or Trailer		
Garage Address 241 HAYDENVILLE RD LEEDS MA 010539768					US DOT Number for Commercial Vehicle		
Name(s) of Owner(s) and Mailing Address 003446 *****AUTO**5-DIGIT 01060 JEFFREY D MILLER 160 MAIN ST STE 8 NORTHAMPTON MA 01060-3187					Insurance Company ARBELLA PROTECTION INSURANCE COMPANY		
					Maximum Seating Capacity for Vehicles for Hire 8		
					Signature of Registrar <i>James Zelen</i> Not-Valid-Without-Official Signature of Registrar		
Lessee/In Custody Of							
Special Message				Change of Address <input type="checkbox"/> Residential <input type="checkbox"/> Mailing <input type="checkbox"/> Garage			

Information for Vehicle Owners

- Certificate of Registration:** Every person operating a motor vehicle shall have the Certificate of Registration for the motor vehicle and/or trailer, in the vehicle, in some easily accessible place. The records of the RMV constitute the official status of the vehicle registration.
- Change of Address:** By law, you must report any change of address to the RMV within 30 days. Visit Mass.Gov/RMV to change your address. Once you have reported the address change to the RMV, please write corrected address in box provided above.
- No Insurance Card Required:** Massachusetts law does not require an insurance card. M.G.L. Chapter 90, section 34, and Chapter 175, Section 113A, requires the vehicle's owner to maintain a compulsory motor vehicle liability insurance policy or bond for bodily injury coverage and property damage insurance. The insurer is required by law to electronically notify the Registry of Motor Vehicles if coverage lapses. The vehicle owner is then notified by the RMV to obtain new insurance within 10 days or the registration will be revoked. Bonds are filed with the State Treasurer's Office.
- Transferring Your Plates: Massachusetts General Law** (M.G.L. Chapter 90, Section 2) allows you to transfer valid registration plates from this vehicle to a newly acquired new or used motor vehicle or trailer while you obtain insurance and a new registration. See the Transferring a Registration Section on the RMV's website at www.mass.gov/rmv for more information.
- Cancel the registration plates if:**
 - The vehicle has been sold or junked and the registration is not going to be transferred to another vehicle.
 - You move to another state and you register the vehicle in that state.
 - The insurance policy is not renewed or is cancelled and there is no plan to obtain a new policy.

212066414



Skip the Line, Go Online! Visit Mass.Gov/RMV for list of available transactions.

Vehicle Inspection Report

Please Review This Important Information

Your vehicle has **PASSED** both its **SAFETY TEST** and its **EMISSIONS TEST**. The results are summarized in this report.

Questions? Visit www.mass.gov/vehiclecheck or call Customer Service at 1-844-358-0135. Customer Service is staffed from 7 a.m. to 5 p.m. Monday, Wednesday, Friday, and Saturday, and from 7 a.m. to 8 p.m. on Tuesday and Thursday.

Overall Result:	PASS	Vehicle Information	Station Information
Safety Result	N/A	VIN	1D8HN44H18B184670
Emissions Result	PASS	License Plate	TA629D
Start Test Date/Time	3/23/2021 8:40 AM	Plate Type/State	TAN / MA
End Test Date/Time	3/23/2021 8:48 AM	Vehicle Type	PASSENGER
Test Type	Regular	Year / Make	2008 Dodge
Sticker Number	221003392	Model	Grand Caravan
Inspection Type	Retest	Fuel Type	GASOLINE
Inspection Counter	2	Engine Cyl / Size	6 / 3L
		GVWR	7000
		Odometer	311460
			ERNIE'S GARAGE INC 72 KING STREET NORTHAMPTON MA (413) 584-0716
			Station Number PB100149 Workstation Number MAW00000648 Inspector Number *****5128
			Inspection Fee \$0.00

Safety Inspection Results

Inspection Comments

None

On-Board Diagnostic (OBD) Results	OBD Readiness Monitor Results	OBD Additional Data
Tampering Check	PASS Catalyst	READY Miles Since Code Clearing 119
Connector Result	PASS Catalyst Heater	UNSUPPORTED Warm-Ups Since Code Clearing 0
RPM Result	PASS Evaporative System	READY Pin 16 Voltage 14.6
Key-On Bulb Check	N/A Secondary Air System	UNSUPPORTED
Engine-Running Bulb Check	N/A A/C System	UNSUPPORTED
Scan Tool Check	N/A Oxygen Sensor	READY
Communication Result	PASS Oxygen Sensor Heater	READY
MIL Status Result	PASS EGR and/or VVT System	READY
Readiness Result	PASS	OBD Diagnostic Trouble Codes
		OBD Permanent Fault Codes
		7F 0A 80

VIR Number



Scan to visit website

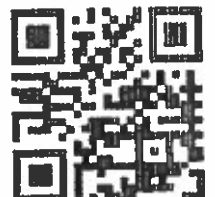



14

GOSMIC CAB

160 MAIN ST.
NORTHAMPTON, MA



COSMIC CAB (413) 230-6119

Massachusetts
629 D
TAXI

14



City of Northampton

Application for Vehicle Registration - Vehicle for Hire

PRINT ALL INFORMATION (except signature)

(Check one) Taxi Vehicle Livery Vehicle

Today's Date: 4/20/21

Name (First, Middle, Last) Jeffrey David Miller

Residential Address 241 Haydenville Rd. Leeds MA 01053
Number Street City/Town State Zip Code

Business Address 160 Main St. Northampton MA 01060
Number Street City/Town State Zip Code

Mailing Address _____
Number Street City/Town State Zip Code

Telephone Number 413-230-6119

Vehicle Information

Make Dodge

Model Grand Caravan

Year 2010

Color Gray

Registration Number TA 27569

Vehicle Id Number 2D4RN4DE8AR207297

Seating Capacity (exclusive of operator) 6

Number of Seat belts 7

Attach the following: Insurance Policy for this vehicle; child safety seat plan; copy of vehicle inspection; color photo of vehicle

*Liability Limits: \$100,000 / \$300,000 injury or death; \$50,000 property damage
 Policy must show that the policy shall not be cancelled without giving the City clerk 10 days notice thereof.*

Sworn to this 18th day of April, 2021, before me.

[Signature]

 City Clerk

FOR LICENSING AUTHORITY USE

In City Council, _____, voted that this petition is _____
 is not _____ granted.

Attest: _____
 Clerk to the City Council



CERTIFICATE OF REGISTRATION

LB

M.G.L. Chapter 90 Section 24B makes it a crime to alter this Certificate
MASSACHUSETTS DEPARTMENT OF TRANSPORTATION

EXTERNAL CODE TAN		REGISTRATION TYPE Taxi Normal		PLATE NUMBER 27569	EFFECTIVE DATE 10-Mar-2021	TITLE NUMBER	EXPIRES ON 30-Nov-2021
MODEL YEAR 2010	MAKE DODG	MODEL CARAVA	MODEL NUMBER	BODY STYLE VAN	COLOR GRAY	VEHICLE IDENTIFICATION NUMBER 2D4RN4DE8AR207297	
RESIDENTIAL ADDRESS (IF DIFFERENT THAN MAILING)						TOTAL REGISTERED WEIGHT FOR A COMMERCIAL VEHICLE OR TRAILER	
GARAGE ADDRESS 24B HAYDENVILLE RD LEEDS MA 01053-9713						US DOT NUMBER FOR COMMERCIAL VEHICLE	
NAME(S) OF OWNER(S) AND MAILING ADDRESS JEFFREY D MILLER 24B HAYDENVILLE RD LEEDS MA 01053-9713						INSURANCE COMPANY ARBELLA PROTECTION INSURANCE COMPANY	
						MAXIMUM SEATING CAPACITY FOR VEHICLES FOR HIRE	
LESSEE/IN CUSTODY OF						<i>James Zerk</i> Registrar of Motor Vehicles	
SPECIAL MESSAGE If this vehicle is newly acquired, it must be inspected within 7 days of registration.					CHANGE OF ADDRESS <input type="checkbox"/> RESIDENTIAL <input type="checkbox"/> MAILING <input type="checkbox"/> GARAGE		

Important information for vehicle owners

- **Certificate of Registration:** Every person operating a motor vehicle shall have the Certificate of Registration for the motor vehicle and/or trailer, in the vehicle, in some easily accessible place. The records of the RMV constitute the official status of the vehicle registration.
- **Change of Address:** By law, you must report any change of address to the RMV within 30 days. Visit mass.gov/rmv to change your address. Once you have reported the address change to the RMV, please write corrected address in box provided above.
- **No Insurance Card Required:** Massachusetts law does not require an insurance card. M.G.L. Chapter 90, Section 34, and Chapter 175, Section 113A, requires the vehicle's owner to maintain a compulsory motor vehicle liability insurance policy or bond for bodily injury coverage and property damage insurance. The insurer is required by law to electronically notify the Registry of Motor Vehicles if coverage lapses. The vehicle owner is then notified by the RMV to obtain new insurance within 10 days or the registration will be revoked. Bonds are filed with the State Treasurer's Office.
- **Transferring Your Plates:** Massachusetts General Law (M.G.L. Chapter 90, Section 2) allows you to transfer valid registration plates from this vehicle to a newly acquired new or used motor vehicle or trailer while you obtain insurance and a new registration. See the Transferring a Registration Section on the RMV's website at mass.gov/rmv for more information.
- **Cancel the registration plates if:**
 - The vehicle has been sold or junked and the registration is not going to be transferred to another vehicle.
 - You move to another state and you register the vehicle in that state.
 - The insurance policy is not renewed or is cancelled and there is no plan to obtain a new policy.

Skip the Line, Go Online! Visit Mass.Gov/RMV for list of available transactions.

Vehicle Inspection Report

Please Review This Important Information

Your vehicle has **PASSED** both its **SAFETY TEST** and its **EMISSIONS TEST**. The results are summarized in this report.

Questions? Visit www.mass.gov/vehiclecheck or call Customer Service at 1-844-358-0135. Customer Service is staffed from 7 a.m. to 5 p.m. Monday, Wednesday, Friday, and Saturday, and from 7 a.m. to 8 p.m. on Tuesday and Thursday.

Overall Result:	PASS	Vehicle Information		Station Information	
Safety Result	PASS	VIN	2D4RN4DE8AR207297	ERNIE'S GARAGE INC	
Emissions Result	PASS	License Plate	27569	72 KING STREET	
Start Test Date/Time	3/15/2021 9:31 AM	Plate Type/State	TAN / MA	NORTHAMPTON	MA
End Test Date/Time	3/15/2021 9:40 AM	Vehicle Type	PASSENGER	(413) 584-0716	
Test Type	Regular	Year / Make	2010 Dodge		
Sticker Number	221003255	Model	Grand Caravan	Station Number	PB100149
Inspection Type	Initial	Fuel Type	GASOLINE	Workstation Number	MAW00000548
Inspection Counter	1	Engine Cyl / Size	6 / 3L	Inspector Number	*****5128
		GVWR	7000		
		Odometer	131150		

Inspection Fee \$35.00

Safety Inspection Results

License Plate Mounting and Condition	PASS	Service Brakes	PASS	Parking Brake	PASS
Horn	PASS	Stop Lights and Tail Lights	PASS	Headlight Aim and Operation	PASS
Lighting Devices and Reflectors	PASS	Directional Signals and 4-Ways	PASS	Front End	PASS
Steering and Suspension	PASS	Frame	PASS	Windshield Wipers and Cleaner	PASS
Safety Belts	PASS	Air Bags	N/A	Muffler and Exhaust System	PASS
Window Tint	PASS	Windshield	PASS	Rear View Mirror	PASS
Bumpers/Fenders/Exterior Sheet Metal	PASS	Fuel Tank Filler Cap	PASS	Fuel Tank Filler Neck and Components	PASS
Visible Smoke	PASS	Altered Vehicle Height	PASS	Tires	PASS
Other	PASS				

Inspection Comments

None

On-Board Diagnostic (OBD) Results	OBD Readiness Monitor Results	OBD Additional Data			
Tampering Check	PASS	Catalyst	READY	Miles Since Code Clearing	14776
Connector Result	PASS	Catalyst Heater	UNSUPPORTED	Warm-Ups Since Code Clearing	255
RPM Result	PASS	Evaporative System	READY	Pin 16 Vcltage	14.5
Key-On BulbCheck	N/A	Secondary Air System	UNSUPPORTED	OBD Diagnostic Trouble Codes	
Engine-Running Bulb Check	N/A	A/C System	UNSUPPORTED		
Scan Tool Check	N/A	Oxygen Sensor	READY		
Communication Result	PASS	Oxygen Sensor Heater	READY		
MIL Status Result	PASS	EGR and/or VVT System	READY	OBD Permanent Fault Codes	
Readiness Result	PASS				

Scan to visit website

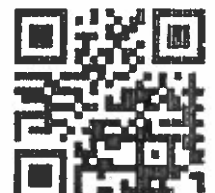

VIR Number









City of Northampton Application for Vehicle Registration - Vehicle for Hire

PRINT ALL INFORMATION (except signature)

(Check one)

Taxi Vehicle

Livery Vehicle

Today's Date: 4/20/21

Name (First, Middle, Last) Jeffrey David Miller

Residential Address 241 Haydenville Rd. Leeds MA 01053
Number Street City/Town State Zip Code

Business Address 160 Main St Northampton MA 01060
Number Street City/Town State Zip Code

Mailing Address _____
Number Street City/Town State Zip Code

Telephone Number 413-230-6119

Vehicle Information

Make Dodge

Model Grand Caravan

Year 2009

Color Blue

Registration Number TA 603C

Vehicle Id Number 2D8HN44E59R576432

Seating Capacity (exclusive of operator) 6

Number of Seat belts 7

Attach the following: Insurance Policy for this vehicle; child safety seat plan; copy of vehicle inspection; color photo of vehicle

*Liability Limits: \$100,000 / \$300,000 injury or death; \$50,000 property damage
Policy must show that the policy shall not be cancelled without giving the City clerk 10 days notice thereof.*

Sworn to this 20th day of April, 2021, before me

[Signature]
City Clerk

FOR LICENSING AUTHORITY USE

In City Council, _____, voted that this petition is _____
is not _____ granted.

Attest: _____
Clerk to the City Council



CERTIFICATE OF REGISTRATION

M.G.L. Chapter 90 section 24B makes it a crime to alter this certificate
MASSACHUSETTS DEPARTMENT OF TRANSPORTATION

Plate Type TAN	Registration Type TAXI NORMAL	Plate Number 603C	Effective Date 01-Dec-2020	Title Number CB535233	Expires On →	Month 11	Year 21
Model Year 2009	Make DODG	Model GRANDC	Body Style VAN	Color(s) BLUE	Vehicle Identification Number 2D8HN44E59R576432		
Residential Address (If Different than Mailing)					Total Registered Weight for Commercial Vehicle or Trailer		
Garage Address 241 HAYDENVILLE RD LEEDS MA 010539768					US DOT Number for Commercial Vehicle		
Name(s) of Owner(s) and Mailing Address 003431 *****AUTO**5-DIGIT 01060 JEFFREY D MILLER 160 MAIN ST STE 8 NORTHAMPTON MA 01060-3187					Insurance Company ARBELLA MUTUAL INSURANCE COMPANY		
					Maximum Seating Capacity for Vehicles for Hire 7		
					Signature of Registrar <i>James J. Jelen</i> Not Valid Without Official Signature of Registrar		
Lessee/In Custody Of							
Special Message				Change of Address <input type="checkbox"/> Residential <input type="checkbox"/> Mailing <input type="checkbox"/> Garage			

Information for Vehicle Owners

- **Certificate of Registration:** Every person operating a motor vehicle shall have the Certificate of Registration for the motor vehicle and/or trailer, in the vehicle, in some easily accessible place. The records of the RMV constitute the official status of the vehicle registration.
- **Change of Address:** By law, you must report any change of address to the RMV within 30 days. Visit Mass.Gov/RMV to change your address. Once you have reported the address change to the RMV, please write corrected address in box provided above.
- **No Insurance Card Required:** Massachusetts law does not require an insurance card. M.G.L. Chapter 90, section 34, and Chapter 175, Section 113A, requires the vehicle's owner to maintain a compulsory motor vehicle liability insurance policy or bond for bodily injury coverage and property damage insurance. The insurer is required by law to electronically notify the Registry of Motor Vehicles if coverage lapses. The vehicle owner is then notified by the RMV to obtain new insurance within 10 days or the registration will be revoked. Bonds are filed with the State Treasurer's Office.
- **Transferring Your Plates:** Massachusetts General Law (M.G.L. Chapter 90, Section 2) allows you to transfer valid registration plates from this vehicle to a newly acquired new or used motor vehicle or trailer while you obtain insurance and a new registration. See the Transferring a Registration Section on the RMV's website at www.mass.gov/rmv for more information.
- **Cancel the registration plates if:**
 - The vehicle has been sold or junked and the registration is not going to be transferred to another vehicle.
 - You move to another state and you register the vehicle in that state.
 - The insurance policy is not renewed or is cancelled and there is no plan to obtain a new policy.



212066399

Skip the Line, Go Online! Visit Mass.Gov/RMV for list of available transactions.



Vehicle Inspection Report

Please Review This Important Information

Your vehicle has **PASSED** both its **SAFETY TEST** and its **EMISSIONS TEST**. The results are summarized in this report.

Questions? Visit www.mass.gov/vehiclecheck or call Customer Service at 1-844-358-0135. Customer Service is staffed from 7 a.m. to 5 p.m. Monday, Wednesday, Friday, and Saturday, and from 7 a.m. to 8 p.m. on Tuesday and Thursday.

Overall Result:	PASS	Vehicle Information	Station Information
Safety Result	PASS	VIN	2D8HN44E59R576432
Emissions Result	PASS	License Plate	603C
Start Test Date/Time	9/9/2020 3:18 PM	Plate Type/State	TAN / MA
End Test Date/Time	9/9/2020 3:25 PM	Vehicle Type	TRUCK
Test Type	Regular	Year / Make	2009 Dodge
Sticker Number	214989126	Model	Grand Caravan
Inspection Type	Initial	Fuel Type	GASOLINE
Inspection Counter	1	Engine Cyl / Size	6 / 3.3L
		GVWR	6000
		Odometer	137924
		Station Number	PB100149
		Workstation Number	MAW00000648
		Inspector Number	*****0933

Inspection Fee \$35.00

Safety Inspection Results

License Plate Mounting and Condition	PASS	Service Brakes	PASS	Parking Brake	PASS
Horn	PASS	Stop Lights and Tail Lights	PASS	Headlight Aim and Operation	PASS
Lighting Devices and Reflectors	PASS	Directional Signals and 4-Ways	PASS	Front End	PASS
Steering and Suspension	PASS	Frame	PASS	Windshield Wipers and Cleaner	PASS
Safety Belts	PASS	Air Bags	N/A	Muffler and Exhaust System	PASS
Window Tint	PASS	Windshield	PASS	Rear View Mirror	PASS
Bumpers/Fenders/Exterior Sheet Metal	PASS	Fuel Tank Filler Cap	PASS	Fuel Tank Filler Neck and Components	PASS
Visible Smoke	PASS	Altered Vehicle Height	PASS	Tires	PASS
Other	PASS				

Inspection Comments

None

On-Board Diagnostic (OBD) Results	OBD Readiness Monitor Results	OBD Additional Data			
Tampering Check	PASS	Catalyst	READY	Miles Since Code Clearing	14505
Connector Result	PASS	Catalyst Heater	UNSUPPORTED	Warm-Ups Since Code Clearing	255
RPM Result	PASS	Evaporative System	READY	Pin 16 Voltage	14.2
Key-On Bulb Check	N/A	Secondary Air System	UNSUPPORTED	OBD Diagnostic Trouble Codes	
Engine-Running Bulb Check	N/A	A/C System	UNSUPPORTED		
Scan Tool Check	PASS	Oxygen Sensor	READY	OBD Permanent Fault Codes	
Communication Result	PASS	Oxygen Sensor Heater	READY		
MIL Status Result	PASS	EGR and/or VVT System	READY		
Readiness Result	PASS			7F 0A 80	

Scan to visit website

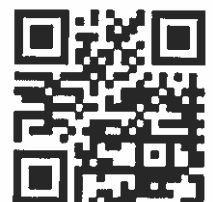

VIR Number



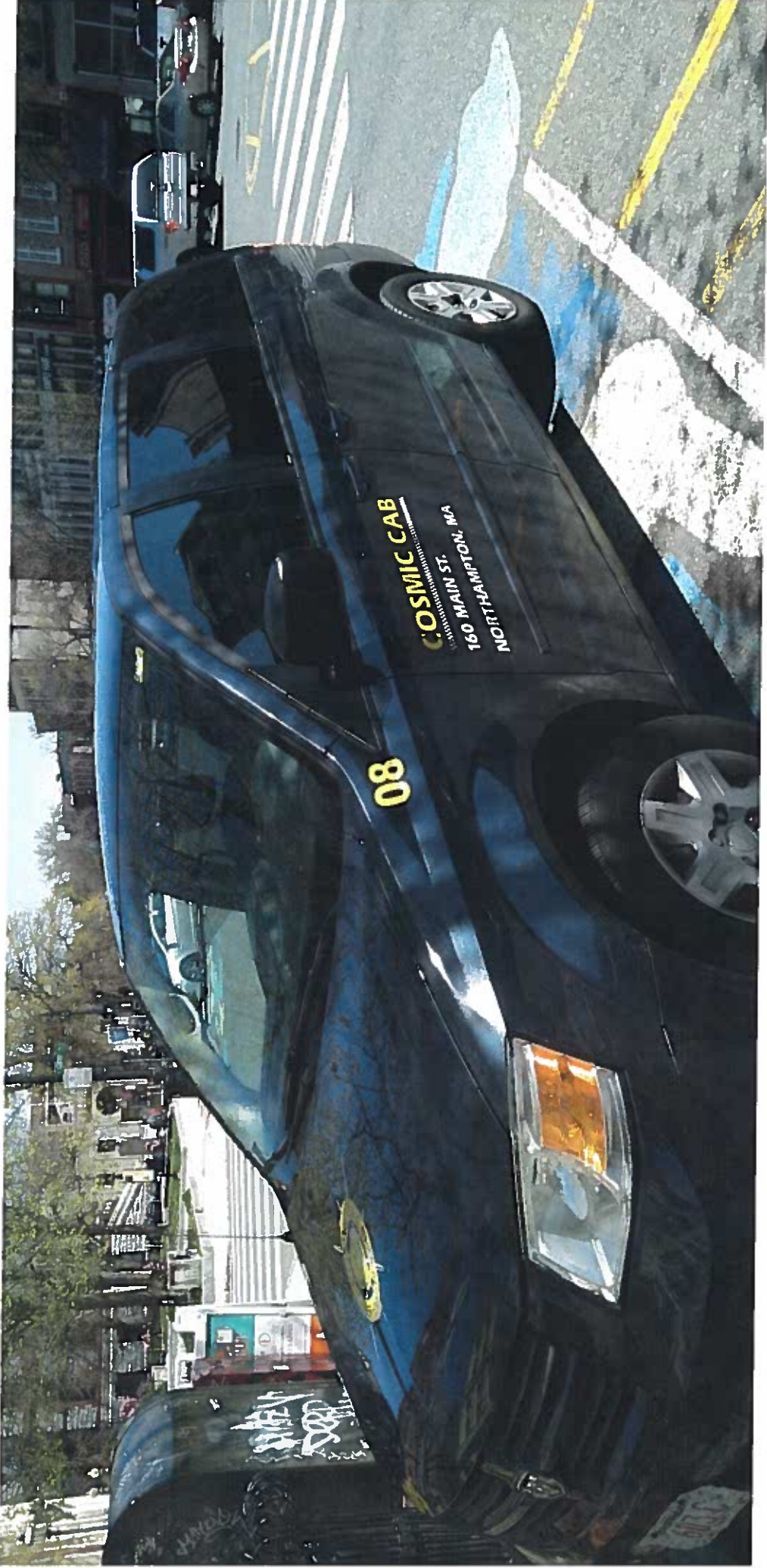

08

COSMIC CAB
160 MAIN ST.
NORTHAMPTON, MA



COSMIC CAB (413) 230-6119

603 C
TAXI

08

BISCI

BOOKS jewelry

NO PARKING
TAXI



City of Northampton Application for Vehicle Registration - Vehicle for Hire

PRINT ALL INFORMATION (except signature)

(Check one)

Taxi Vehicle

Livery Vehicle

Today's Date: 4/20/21

Name (First, Middle, Last) Jeffrey David Miller

Residential Address 241 Haydenville Rd. Leeds MA 01053
Number Street City/Town State Zip Code

Business Address 160 Main St Northampton MA 01060
Number Street City/Town State Zip Code

Mailing Address _____
Number Street City/Town State Zip Code

Telephone Number 413-230-6119

Vehicle Information

Make Dodge

Model Grand Caravan

Year 2008

Color Black

Registration Number TA 26981

Vehicle Id Number 1D8HN44H0B8162479

Seating Capacity (exclusive of operator) 6

Number of Seat belts 7

Attach the following: Insurance Policy for this vehicle; child safety seat plan; copy of vehicle inspection; color photo of vehicle

*Liability Limits: \$100,000 / \$300,000 injury or death; \$50,000 property damage
Policy must show that the policy shall not be cancelled without giving the City clerk 10 days notice thereof.*

Sworn to this 28th day of April, 2021, before me.

[Signature]
City Clerk

FOR LICENSING AUTHORITY USE

In City Council, _____, voted that this petition is _____ is not _____ granted.

Attest: _____
Clerk to the City Council

Vehicle Inspection Report



Please Review This Important Information

Your vehicle has PASSED both its SAFETY TEST and its EMISSIONS TEST. The results are summarized in this report.

Questions? Visit www.mass.gov/vehiclecheck or call Customer Service at 1-844-358-0135. Customer Service is staffed from 7 a.m. to 5 p.m. Monday, Wednesday, Friday, and Saturday, and from 7 a.m. to 8 p.m. on Tuesday and Thursday.

Overall Result: PASS		Vehicle Information		Station Information	
Safety Result	PASS	VIN	1D8HN44H08B162479	ERIE'S GARAGE INC	
Emissions Result	PASS	License Plate	TA26981	72 KING STREET	
Start Test Date/Time	2/27/2021 8:39 AM	Plate Type/State	TAN / MA	NORTHAMPTON	MA
End Test Date/Time	2/27/2021 8:44 AM	Vehicle Type	TRUCK	(413) 584-0716	
Test Type	Regular	Year / Make	2008 Dodge	Station Number	PB100149
Sticker Number	220999340	Model	Grand Caravan	Workstation Number	MAW00000648
Inspection Type	Initial	Fuel Type	GASOLINE	Inspector Number	*****0933
Inspection Counter	1	Engine Cyl / Size	6 / 3L		
		GVWR	7000		
		Odometer	323240		

Inspection Fee \$35.00

Safety Inspection Results

License Plate Mounting and Condition	PASS	Service Brakes	PASS	Parking Brake	PASS
Horn	PASS	Stop Lights and Tail Lights	PASS	Headlight Aim and Operation	PASS
Lighting Devices and Reflectors	PASS	Directional Signals and 4-Ways	PASS	Front End	PASS
Steering and Suspension	PASS	Frame	PASS	Windshield Wipers and Cleaner	PASS
Safety Belts	PASS	Air Bags	N/A	Muffler and Exhaust System	PASS
Window Tint	PASS	Windshield	PASS	Rear View Mirror	PASS
Bumpers/Fenders/Exterior Sheet Metal	PASS	Fuel Tank Filler Cap	PASS	Fuel Tank Filler Neck and Components	PASS
Visible Smoke	PASS	Altered Vehicle Height	PASS	Tires	PASS
Other	PASS				

Inspection Comments

None

On-Board Diagnostic (OBD) Results

On-Board Diagnostic (OBD) Results	OBDR Readiness Monitor Results	OBDR Additional Data
Tampering Check	PASS	Catalyst
Connector Result	PASS	Catalyst Heater
RPM Result	PASS	Evaporative System
Key-On Bulb Check	N/A	Secondary Air System
Engine-Running Bulb Check	N/A	A/C System
Scan Tool Check	N/A	Oxygen Sensor
Communication Result	PASS	Oxygen Sensor Heater
MIL Status Result	PASS	EGR and/or VVT System
Readiness Result	PASS	

OBDR Additional Data

Miles Since Code Clearing	34201
Warm-Ups Since Code Clearing	255
Pin 16 Voltage	13.4

OBDR Diagnostic Trouble Codes

OBDR Permanent Fault Codes
7F 0A 80

VIR Number



Scan to visit website





CERTIFICATE OF REGISTRATION

M.G.L. Chapter 90 section 24B makes it a crime to alter this certificate
MASSACHUSETTS DEPARTMENT OF TRANSPORTATION

Plate Type TAN	Registration Type TAXI NORMAL	Plate Number 26981	Effective Date 01-Dec-2020	Title Number BS088668	Expires On →	Month 11	Year 21
Model Year 2008	Make DODG	Model CARAVA	Body Style VAN	Color(s) BLACK	Vehicle Identification Number 1D8HN44H08B162479		
Residential Address (If Different than Mailing)				Total Registered Weight for Commercial Vehicle or Trailer			
Garage Address 241 HAYDENVILLE RD LEEDS MA 010539768				US DOT Number for Commercial Vehicle			
Name(s) of Owner(s) and Mailing Address 003444 *****AUTO**5-DIGIT 01060 JEFFREY D MILLER 160 MAIN ST STE 8 NORTHAMPTON MA 01060-3187				Insurance Company ARBELLA PROTECTION INSURANCE COMPANY			
				Maximum Seating Capacity for Vehicles for Hire 7			
				<i>Jeffrey Miller</i> Not Valid Without Official Signature of Registrar			
Lessee/In Custody Of							
Special Message				Change of Address <input type="checkbox"/> Residential <input type="checkbox"/> Mailing <input type="checkbox"/> Garage			

Information for Vehicle Owners

- **Certificate of Registration:** Every person operating a motor vehicle shall have the Certificate of Registration for the motor vehicle and/or trailer, in the vehicle, in some easily accessible place. The records of the RMV constitute the official status of the vehicle registration.
- **Change of Address:** By law, you must report any change of address to the RMV within 30 days. Visit Mass.Gov/RMV to change your address. Once you have reported the address change to the RMV, please write corrected address in box provided above.
- **No Insurance Card Required:** Massachusetts law does not require an insurance card. M.G.L. Chapter 90, section 34, and Chapter 175, Section 113A, requires the vehicle's owner to maintain a compulsory motor vehicle liability insurance policy or bond for bodily injury coverage and property damage insurance. The insurer is required by law to electronically notify the Registry of Motor Vehicles if coverage lapses. The vehicle owner is then notified by the RMV to obtain new insurance within 10 days or the registration will be revoked. Bonds are filed with the State Treasurer's Office.
- **Transferring Your Plates:** Massachusetts General Law (M.G.L. Chapter 90, Section 2) allows you to transfer valid registration plates from this vehicle to a newly acquired new or used motor vehicle or trailer while you obtain insurance and a new registration. See the Transferring a Registration Section on the RMV's website at www.mass.gov/rmv for more information.
- **Cancel the registration plates if:**
 - The vehicle has been sold or junked and the registration is not going to be transferred to another vehicle.
 - You move to another state and you register the vehicle in that state.
 - The insurance policy is not renewed or is cancelled and there is no plan to obtain a new policy.



212066412

Skip the Line, Go Online! Visit Mass.Gov/RMV for list of available transactions.

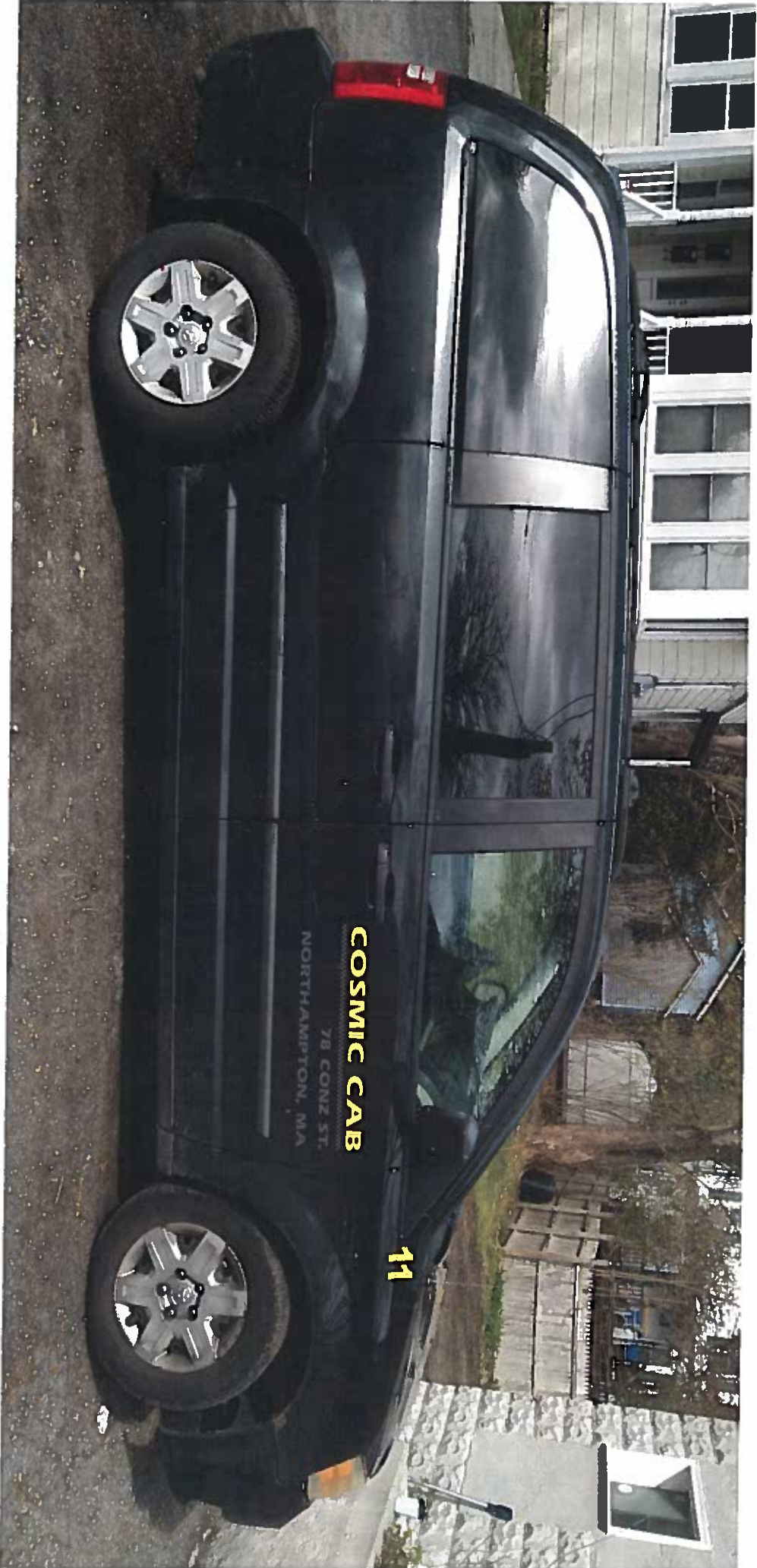

COSMIC CAB

78 CONZ ST.
NORTHAMPTON, MA

11

A.R. CONZ, INC.
MECHANICAL
CONTRACTORS
NORTHAMPTON MASSACHUSETTS
584-4698

COSMIC CAB (413) 230-6119

Massachusetts
26981
TAXI

11



City of Northampton
Application for Vehicle Registration - Vehicle for Hire

PRINT ALL INFORMATION (except signature)

(Check one) Taxi Vehicle Livery Vehicle Today's Date: 4/20/21

Name (First, Middle, Last) Jeffrey David Miller

Residential Address 241 Hunderville Rd. Leeds MA 01053
Number Street City/Town State Zip Code

Business Address 160 Main St. #8 Northampton MA 01060
Number Street City/Town State Zip Code

Mailing Address _____
Number Street City/Town State Zip Code

Telephone Number 413-687-8865

Vehicle Information

Make Chevrolet

Registration Number TA 26977

Model Suburban

Vehicle Id Number 3GNFK16367G155614

Year 2007

Seating Capacity (exclusive of operator) 6

Color Brown

Number of Seat belts 7

Attach the following: Insurance Policy for this vehicle; child safety seat plan; copy of vehicle inspection; color photo of vehicle

Liability Limits: \$100,000 / \$300,000 injury or death; \$50,000 property damage
Policy must show that the policy shall not be cancelled without giving the City clerk 10 days notice thereof.

Sworn to this 28th day of April, 2021, before me.

[Signature]
City Clerk

FOR LICENSING AUTHORITY USE

In City Council, _____, voted that this petition is _____
is not _____ granted.

Attest: _____
Clerk to the City Council



Vehicle Inspection Report

Please Review This Important Information

Your vehicle has **PASSED** both its **SAFETY TEST** and its **EMISSIONS TEST**. The results are summarized in this report.

Questions? Visit www.mass.gov/vehiclecheck or call Customer Service at 1-844-358-0135. Customer Service is staffed from 7 a.m. to 5 p.m. Monday, Wednesday, Friday, and Saturday, and from 7 a.m. to 8 p.m. on Tuesday and Thursday.

Overall Result:	PASS	Vehicle Information		Station Information	
Safety Result	PASS	VIN	3GNFK16367G155614	ERNIE'S GARAGE INC	
Emissions Result	PASS	License Plate	TA26977	72 KING STREET	
Start Test Date/Time	3/20/2021 8:16 AM	Plate Type/State	TAN / MA	NORTHAMPTON	MA
End Test Date/Time	3/20/2021 8:23 AM	Vehicle Type	TRUCK	(413) 584-0716	
Test Type	Regular	Year / Make	2007 Chevrolet	Station Number	PB100149
Slicker Number	221003358	Model	Suburban	Workstation Number	MAW00000648
Inspection Type	Initial	Fuel Type	FLEXIBLE	Inspector Number	*****0933
Inspection Counter	1	Engine Cyl / Size	8 / 5L		
		GVWR	8000		
		Odometer			

Inspection Fee	\$35.00
-----------------------	----------------

Safety Inspection Results

License Plate-Mounting and Condition	PASS	Service Brakes	PASS	Parking Brake	PASS
Horn	PASS	Stop Lights and Tail Lights	PASS	Headlight Aim and Operation	PASS
Lighting Devices and Reflectors	PASS	Directional Signals and 4-Ways	PASS	Front End	PASS
Steering and Suspension	PASS	Frame	PASS	Windshield Wipers and Cleaner	PASS
Safety Belts	PASS	Air Bags	N/A	Muffler and Exhaust System	PASS
Window Tint	PASS	Windshield	PASS	Rear View Mirror	PASS
Bumpers/Fenders/Exterior Sheet Metal	PASS	Fuel Tank Filler Cap	PASS	Fuel Tank Filler Neck and Components	PASS
Visible Smoke	PASS	Altered Vehicle Height	PASS	Tires	PASS
Other	PASS				

Inspection Comments

None

On-Board Diagnostic (OBD) Results	OBD Readiness Monitor Results	OBD Additional Data			
Tampering Check	PASS	Catalyst	READY	Miles Since Code Clearing	76
Connector Result	PASS	Catalyst Heater	UNSUPPORTED	Warm-Ups Since Code Clearing	6
RPM Result	PASS	Evaporative System	NOT READY	Pin 16 Voltage	14.9
Key-On Bulb Check	N/A	Secondary Air System	UNSUPPORTED	OBD Diagnostic Trouble Codes	
Engine-Running Bulb Check	N/A	A/C System	UNSUPPORTED		
Scan Tool Check	N/A	Oxygen Sensor	READY	OBD Permanent Fault Codes	
Communication Result	PASS	Oxygen Sensor Heater	READY		
MIL Status Result	PASS	EGR and/or VVT System	UNSUPPORTED		
Readiness Result	PASS				

Scan to visit website



VIR Number





CERTIFICATE OF REGISTRATION

M.G.L. Chapter 90 section 24B makes it a crime to alter this certificate
MASSACHUSETTS DEPARTMENT OF TRANSPORTATION

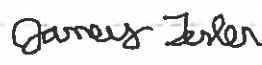
Plate Type TAN	Registration Type TAXI NORMAL	Plate Number 26977	Effective Date 01-Dec-2020	Title Number BV081520	Expires On →	Month 11	Year 21
Model Year 2007	Make CHEV	Model K15BLA	Body Style SUV	Color(s) BROWN	Vehicle Identification Number 3GNFK16367G155614		
Residential Address (if Different than Mailing)					Total Registered Weight for Commercial Vehicle or Trailer		
Garage Address 241 HAYDENVILLE RD LEEDS MA 010539768					US DOT Number for Commercial Vehicle		
Name(s) of Owner(s) and Mailing Address  003445 *****AUTO**5-DIGIT 01060 JEFFREY D MILLER 160 MAIN ST STE 8 NORTHAMPTON MA 01060-3187					Insurance Company ARBELLA PROTECTION INSURANCE COMPANY		
					Maximum Seating Capacity for Vehicles for Hire 7		
					 Not Valid Without Official Signature of Registrar		
Lessee/In Custody Of							
Special Message				Change of Address <input type="checkbox"/> Residential <input type="checkbox"/> Mailing <input type="checkbox"/> Garage			

Information for Vehicle Owners

- **Certificate of Registration:** Every person operating a motor vehicle shall have the Certificate of Registration for the motor vehicle and/or trailer, in the vehicle, in some easily accessible place. The records of the RMV constitute the official status of the vehicle registration.
- **Change of Address:** By law, you must report any change of address to the RMV within 30 days. Visit Mass.Gov/RMV to change your address. Once you have reported the address change to the RMV, please write corrected address in box provided above.
- **No Insurance Card Required:** Massachusetts law does not require an insurance card. M.G.L. Chapter 90, section 34, and Chapter 175, Section 113A, requires the vehicle's owner to maintain a compulsory motor vehicle liability insurance policy or bond for bodily injury coverage and property damage insurance. The insurer is required by law to electronically notify the Registry of Motor Vehicles if coverage lapses. The vehicle owner is then notified by the RMV to obtain new insurance within 10 days or the registration will be revoked. Bonds are filed with the State Treasurer's Office.
- **Transferring Your Plates:** Massachusetts General Law (M.G.L. Chapter 90, Section 2) allows you to transfer valid registration plates from this vehicle to a newly acquired new or used motor vehicle or trailer while you obtain insurance and a new registration. See the Transferring a Registration Section on the RMV's website at www.mass.gov/rmv for more information.
- **Cancel the registration plates if:**
 - The vehicle has been sold or junked and the registration is not going to be transferred to another vehicle.
 - You move to another state and you register the vehicle in that state.
 - The insurance policy is not renewed or is cancelled and there is no plan to obtain a new policy.

212066413



Skip the Line, Go Online! Visit Mass.Gov/RMV for list of available transactions.

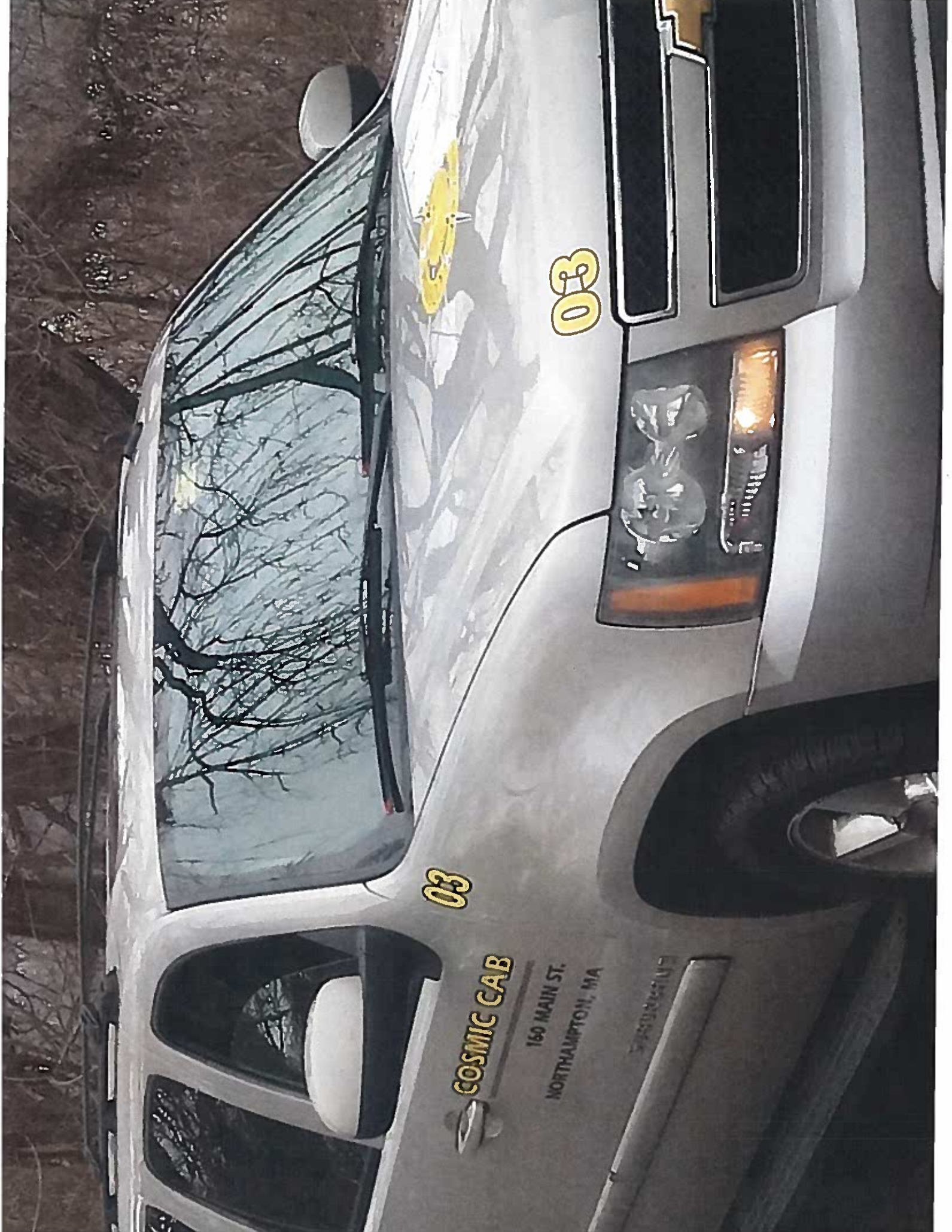

03

03

COSMIC CAB

160 MAIN ST.
NORTHAMPTON, MA

1500



COSMIC CAB
100 W. MAIN ST.
NORTHAMPTON, MA

03

COSMIC CAB (413)230-6119

269777



April 26, 2021

Child Safety Seat Plan 2021/22.

As per the order of the City of Northampton 319-19-4

Cosmic Cab will provide a front or rear facing Child Safety Seat or Booster Seat upon the request of any customer. The customer will need to schedule at least 1 hour in advance to ensure the availability of the safety restraint required.

Best Regards,

A handwritten signature in black ink, appearing to read 'Jeffrey D. Miller', with a long horizontal flourish extending to the right.

Jeffrey D. Miller

Owner

Cosmic Cab Company 160 Main St. #8, Northampton, MA 01060

(413) 230-6119

Office / Agent: 46-0028
 Tax I.D. No.:
 Policy Number: 1020093350 02

**DECLARATIONS - MASSACHUSETTS
 BUSINESS AUTO COVERAGE FORM
 MM 00 97 09 98**



ITEM ONE - NAMED INSURED AND ADDRESS
 JEFF MILLER
 DBA COSMIC CAB
 160 MAIN ST STE B
 NORTHAMPTON, MA 01060

Producer Name and Address 46-0028
 LIGHTHOUSE INS AGCY LTD
 540 GALLIVAN BLVD
 SUITE 211
 DORCHESTER, MA 02124

POLICY PERIOD: Policy Covers FROM 01/18/2021 TO 01/18/2022 12:01 A.M. Standard Time at the Named Insured's Address stated above
Reason for Declaration: VC ENDORSEMENT
Named Insured's Business: INDIVIDUAL DIRECT BILL
Effective Date: 04/20/2021

IN RETURN FOR THE PAYMENT OF THE PREMIUM, AND SUBJECT TO ALL TERMS OF THIS POLICY, WE AGREE WITH YOU TO PROVIDE THE INSURANCE AS STATED IN THIS POLICY.

ITEM TWO - SCHEDULE OF COVERAGES AND COVERED AUTOS

This policy provides only those coverages where a charge is shown in the premium column below. Each of these coverages will apply only to those "Autos" shown as covered "Autos" for a particular coverage by the entry of one or more of the symbols from the COVERED AUTOS Section of the Business Auto Coverage Form next to the name of the coverage.

LIABILITY INSURANCE

COVERAGES	COVERED AUTOS (Entry of one or more of the symbols from the COVERED AUTOS Section of the Business Auto Coverage Form show which autos are covered autos.)	LIMIT The most we will pay for any one accident or loss	PREMIUM
Compulsory Bodily Injury	7	20,000 Each Person 40,000 Each Accident	11,081
Personal Injury Protection	7	8,000 Each Person	4,354
Optional Bodily Injury	7	100,000 Each Person 300,000 Each Accident	13,279
Property Damage (COMPULSORY LIMIT \$5,000)	7	50,000 Each Accident	10,598
Auto Medical Payments Insurance		Each Person	
Uninsured Motorists (COMPULSORY LIMITS \$20,000/\$40,000)	7	SEE SCHEDULE Each Person SEE SCHEDULE Each Accident	308
Underinsured Motorists	7	SEE SCHEDULE Each Person SEE SCHEDULE Each Accident	INCL

PHYSICAL DAMAGE INSURANCE

Actual Cash Value or cost of repair, whichever is less, minus the deductible for each Covered Auto.

Comprehensive Coverage		Deductible	
Specified Perils Coverage		Deductible	
Collision Coverage		Deductible	
Limited Collision Coverage		Deductible	

Loss of Use-Rental Reimbursement		For each disablement of a private passenger auto.	
Towing and Labor			

Forms and Endorsements attached to this Coverage Form:

26 AP 1056 (01/10) CA 00 01 (10/01) IL 00 21 (04/98)
 26 AP 1057 (01/10) CA 23 86 (01/06) MM 99 11 (10/11)
 26 AP 1092 (01/10) CA 24 02 (12/93) MM 99 18 (09/98)
 26 AP 1102 (04/11) CA 99 17 (07/97) MM 99 23 (09/98)
 26 AP 1109 (07/16) IL 00 17 (11/85) MM 99 54 (09/98)

PREMIUM FOR ENDORSEMENTS	
ADDITIONAL OR RETURN PREMIUM	
*ESTIMATED TOTAL PREMIUM	39,620

* This policy may be subject to final audit.

includes copyrighted material of Insurance Services Office with its permission

Countersigned by

Authorized Representative

INSURED COPY
 04/23/2021

Office / Agent: 46-0028
 Tax I.D. No.:
 Policy Number: 1020093350 02

DECLARATIONS - MASSACHUSETTS
 BUSINESS AUTO COVERAGE FORM
 SCHEDULE - MM 00 97 09 98



ITEM THREE - SCHEDULE OF COVERED AUTOS YOU OWN

VEHICLE INFORMATION

DESCRIPTION				
Auto No.	Year, Make, Model, Body Vehicle Identification No. (VIN)	Original Cost New	Size GVW, GCW or Seating Capacity	Territory, City & State where the covered auto will be garaged
001	2008 DODGE GRAND CARAVAN SE EXTENDED 1D8HN44H08B162479	21,740		MA LEEDS
002	2008 DODGE GRAND CARAVAN SE EXTENDED 1D8HN44H18B184670	21,740		MA LEEDS
003	2007 CHEVROLET SUBURBAN K1500 WAGON 4 3GNFK16367G155614	39,665		MA LEEDS
004	2005 DODGE MAGNUM SXT WAGON 4 DR. 2D4GZ48VX5H511216	27,900		MA LEEDS

CLASSIFICATION

Auto No.	Business use - Service Retail, Commercial	Symbol	Age Group	Class	Radius of Operation	Mobile Equip	Inspect Code	Loss of Use Am/Days
001		07	9	41890	LOCAL			/
002		07	9	41890	LOCAL			/
003		08	9	41890	LOCAL			/
004		08	9	41890	LOCAL			/

LIABILITY LIMITS (* Limit(s) in Thousands)

Auto No.	Compulsory Bodily Injury (\$20,000/\$40,000) each pers./each acc.		Personal Injury Protection \$8,000 Ea Person		Optional Bodily Injury		Property Damage (Compulsory Limit \$5,000)		Auto Medical Payments		Uninsured Motorists Compulsory Limits (\$20,000/\$40,000)		Underinsured Motorists	
	Premium	Premium	*Limit	Premium	*Limit	Ded.	Premium	Limit	Premium	*Limit	Premium	*Limit	Premium	
001	1,583	622	100 300	1,897	50		1,514			20 40	44	20 40	INCL	
002	1,583	622	100 300	1,897	50		1,514			20 40	44	20 40	INCL	
003	1,583	622	100 300	1,897	50		1,514			20 40	44	20 40	INCL	
004	1,583	622	100 300	1,897	50		1,514			20 40	44	20 40	INCL	

PHYSICAL DAMAGE

Auto No.	@ Value Type and Limit	** Specified Perils			Comprehensive		Collision		Limited Collision	
		Cov	Ded.	Premium	Ded.	Premium	Ded.	Premium	Ded.	Premium
001	ACV									
002	ACV									
003	ACV									
004	ACV									

** F - Fire Coverage, T - Theft Coverage, F&T - Fire and Theft, CAC - Combined Additional Coverage.
 *** YES - Designates Waiver of Deductible.
 ## Designates Policy Level Additional Insured - Lessor applies.
 @ Designates whether Actual Cash Value, Stated Amount or Agreed Value and, except for ACV, the limit of Liability.

Auto No. Except for towing all physical damage loss is payable to you and the loss payee named below as interests may appear at the time of loss.

Includes copyrighted material of Insurance Services Office with its permission.

INSURED COPY
 04/21/2021

Office / Agent: 46-0028

Tax I.D. No.:

Policy Number: 1020093350 02

**DECLARATIONS - MASSACHUSETTS
BUSINESS AUTO COVERAGE FORM
SCHEDULE - MM 00 97 09 98**



ITEM THREE - SCHEDULE OF COVERED AUTOS YOU OWN

VEHICLE INFORMATION

DESCRIPTION				
Auto No.	Year, Make, Model, Body Vehicle Identification No. (VIN)	Original Cost New	Size GVW, GCW or Seating Capacity	Territory, City & State where the covered auto will be garaged
006	2009 DODGE GRAND CARAVAN SE SPORT VAN 2D8HN44E59R576432	23,530		LEEDS MA
009	2010 DODGE GRAND CARAVAN SE SPORT VAN 2D4RN4DE8AR207297	23,175		LEEDS MA
010	2008 DODGE GRAND CARAVAN SE EXTENDED 2D8HN44HX8R772469	21,740		LEEDS MA

CLASSIFICATION								
Auto No.	Business use - Service Retail, Commercial	Symbol	Age Group	Class	Radius of Operation	Mobile Equip	Inspect Code	Loss of Use Amt/Days
006		07	9	41890	LOCAL			/
009		07	9	41890	LOCAL			/
010		07	9	41890	LOCAL			/

LIABILITY LIMITS (* Limits) in Thousands															
Auto No.	Compulsory Bodily Injury (\$20,000/\$10,000) each pers./each acc.		Personal Injury Protection \$8,000 Ea Person		Optional Bodily Injury		Property Damage (Compulsory Limit \$5,000)			Auto Medical Payments		Uninsured Motorists Compulsory Limits (\$20,000/\$40,000)		Underinsured Motorists	
	Premium	Premium	*Limit	Premium	*Limit	Ded.	Premium	Limit	Premium	*Limit	Premium	*Limit	Premium	*Limit	Premium
006	1,583	622	100	1,897	50		1514			20	44	20		20	INCL
009	1,583	622	100	1,897	50		1,514			20	44	20		20	INCL
010	1,583	622	100	1,897	50		1,514			20	44	20		20	INCL

PHYSICAL DAMAGE										
Auto No.	Value Type and Limit	Specified Perils			Comprehensive		Collision		Limited Collision	
		Cov.	Ded.	Premium	Ded.	Premium	Ded.	Premium	Ded.	Premium
006	ACV									
009	ACV									
010	ACV									

Auto No.	Passive Rest.	ATD	Waiver of Ded.	Loss of Use	Towing and Labor	Notes
						** F - Fire Coverage, T - Theft Coverage, F&T - Fire and Theft, CAC - Combined Additional Coverage. *** YES-Designates Waiver of Deductible. # Designates Policy Level Additional Insured - Lessor applies. @ Designates whether Actual Cash Value, Stated Amount or Agreed Value and, except for ACV, the limit of Liability.

Auto No. Except for towing all physical damage loss is payable to you and the loss payee named below as interests may appear at the time of loss.

Includes copyrighted material of Insurance Services Office with its permission.

INSURED COPY
04/23/2021

Office / Agent: 46-0028
 Tax I.D. No.:
 Policy Number: 1020093350 02

DECLARATIONS - MASSACHUSETTS
 BUSINESS AUTO COVERAGE FORM
 (Continued) - MM 00 97 09 98



ITEM FOUR- SCHEDULE OF HIRED OR BORROWED COVERED AUTO COVERAGE AND PREMIUMS
 LIABILITY COVERAGE - RATING BASIS, COST OF HIRE

State	Estimated Cost of Hire for each State	Rate per each \$100 Cost of Hire		Factor (if liab. cov. is Primary)	Premium	
		Bod. Injury	Prop. Damage		Bod. Injury	Prop. Damage
Total Premium						

Cost of Hire means the total amount you incur for the hire of "autos" you don't own (not including "autos" you borrow or rent from your partners or employees or their family members). Cost of Hire does not include charges for services performed by motor cameras of property or passengers.

PHYSICAL DAMAGE COVERAGE

Coverages	Limit of Insurance The most we will pay, Deductible	Estimated Annual Cost of Hire	Rate per each \$100 Annual Cost of Hire	Premium
Comprehensive	Actual Cash Value, Cost of Repairs or Collision Whichever is less, minus \$ deductible for each covered auto, but no deductible applies to loss caused by fire or lightning			
Specific causes of Loss	Whichever is less, minus \$25.00 deductible for each covered auto for loss caused by mischief or vandalism			
	Whichever is less, minus \$ deductible for each covered auto			
Total Premium				

ITEM FIVE- SCHEDULE FOR NON-OWNERSHIP LIABILITY

Named Insured's Business	Rating Basis	Number	Premium	
			Bodily Injury	Prop. Damage
Other than a Social Services Agency	No. of Employees			
Social Services Agency	No. of Partners			
	No. of Employees			
	No. of Volunteers			
Total Premium				

ITEM SIX- SCHEDULE FOR GROSS RECEIPTS OR MILEAGE BASIS-
 LIABILITY COVERAGE-PUBLIC AUTO LEASING RENTAL CONCERNS

Estimated Yearly	Rates		Premiums	
	Liability Coverage	Auto Medical Payments	Liability Coverage	Auto Medical Payments
<input type="checkbox"/> Gross Receipts	<input type="checkbox"/> Per \$100 of Gross Receipts			
<input type="checkbox"/> Mileage	<input type="checkbox"/> Per mile			
Total Premiums				
Minimum Premiums				

When used as a premium basis FOR PUBLIC AUTOS

Gross Receipts means the total amount to which you are entitled for transporting passengers, mail or merchandise during the policy period regardless of whether you or any other carrier originate the transportation. Gross receipts does not include:
 A. Amount you pay to railroads, steamship lines, airlines and other motor carriers operating under their own ICC or PUC permits.
 B. Taxes which you collect as a separate item and remit directly to a governmental division.
 C. C.O.D. collections for cost of mail or merchandise including collections fees.
 D. Advertising Revenue.

Mileage means the total live and dead mileage of all revenue producing units operated during the policy period.

FOR RENTAL OR LEASING CONCERNS

Gross receipts means the total amount to which you are entitled for the leasing or rental of "autos" during the policy period and includes taxes except those taxes which you collect as a separate item and remit directly to a governmental division.

Mileage means the total of all live and dead mileage developed by all the "autos" you leased or rented to others during the policy period.

Driver Information:

Drv. No.	Driver Name	Date of Birth	License Number	State

Includes copyrighted material of Insurance Services Office with its permission.

INSURED COPY
 04/23/2021

THIS ENDORSEMENT CHANGES THE POLICY. PLEASE READ IT CAREFULLY.

DESCRIPTION OF POLICY CHANGES

POLICY NUMBER 1020093350 02	POLICY CHANGES EFFECTIVE 04/20/2021	COMPANY ARBELLA PROTECTION
NAMED INSURED JEFF MILLER		AUTHORIZED REPRESENTATIVE
<p style="text-align: center;">CHANGES</p> TRANSFER 2010 DODGE VIN 4867 TO 2008 DODGE VIN 2469		



MAYOR DAVID J. NARKEWICZ

City of Northampton

Office of the Mayor

210 Main Street Room 12

Northampton, MA 01060-3199

(413) 587-1249 Fax: (413) 587-1275

mayor@northamptonma.gov

DATE: May 6, 2021

TO: City Council

FROM: Mayor David J. Narkewicz

SUBJECT: Reappointments to Boards, Committees, and Commissions

Please find the attached reappointments to City Boards, Committees, and Commissions:

Agricultural Commission

John J. Bobala, 25 Old Ferry Road, Northampton

Term: July 2021-June 2024

Reappointment

Richard E. Jaescke, 774 Bridge Road, Northampton

Term: July 2021-June 2024

Reappointment

Robert Vollinger, 460 North Farms Road, Florence

Term: July 2021-June 2023

Reappointment

Earle "Chip" Parsons, 137 Mill Valley Road, Hadley

Term: July 2021-June 2023

Reappointment

Central Business Architecture Committee

Joseph Blumenthal, 39 Chapel St., Northampton

Term: July 2021-June 2024

Reappointment

Urban Forestry Commission

Susan Lofthouse, 15 Stoddard Street, Northampton

Term: July 2021-June 2024

Reappointment

Council on Aging

Robert Dionne, 87 Vernon Street, Northampton

Term: July 2021-June 2024

Reappointment

Jeanne Hoose, 36 South Park Terrace, Northampton

Term: July 2021-June 2024

Reappointment

Historical Commission

Dylan Gafney, 23 Marshall Street, Northampton

Term: July 2019-June 2022

Reappointment

Barbara Blumenthal, 39 Chapel Street, Northampton

Term: July 2021-June 2024

Reappointment

Housing Partnership

Julio Alves, 35 Fort Hill Terrace, Northampton

Term: July 2021- June 2024

Reappointment

James Reis, 108 Coles Meadow Road, Northampton

Term: July 2021-June 2024

Reappointment

Parks and Recreation Commission

Julia Chevan, 8 Cosmian Avenue, Florence

Term: July 2020-June 2023

Reappointment

Planning Board

George Kohout, Full Member, 234 State Street, Northampton

Term: July 2021-June 2024

Reappointment

Zoning Board of Appeals

Maureen Scanlon, 197 Nonotuck Street, Florence

Term: July 2021-June 2024

Reappointment



City of Northampton Application for Appointment to Boards, Committees and Commissions

Name: John J Bobala
 Address: 25 Old Ferry Rd Northampton MA 01060
 Email: J Bobala@yahoo.com
 Home Phone: 413 586 2704 Work: RETIRED Cell: 413-335-8970
 Occupation: Vocational Instructor Years lived in Northampton: 70 yrs
 Northampton Resident: Yes No

Please indicate the Committee(s) you have interest serving on: *(Appointment subject to vacancies)*

<input checked="" type="checkbox"/> Agricultural Commission	<input type="checkbox"/> License Commission
<input type="checkbox"/> Almoners, Board of	<input type="checkbox"/> Municipal Affordable Housing Trust Fund Board of Trustees
<input type="checkbox"/> Arts Council	<input type="checkbox"/> Parks and Recreation Commission
<input type="checkbox"/> Assessors, Board of	<input type="checkbox"/> Planning Board
<input type="checkbox"/> Central Business Architecture Committee	<input type="checkbox"/> Public Shade Tree Commission
<input type="checkbox"/> Community Preservation Committee	<input type="checkbox"/> Public Works Commission
<input type="checkbox"/> Conservation Commission	<input type="checkbox"/> Redevelopment Authority
<input type="checkbox"/> Council on Aging	<input type="checkbox"/> Registrars, Board of
<input type="checkbox"/> Disability Commission	<input type="checkbox"/> Transportation & Parking Commission
<input type="checkbox"/> Energy & Sustainability Commission	<input type="checkbox"/> Trust Fund Committee
<input type="checkbox"/> Health, Board of	<input type="checkbox"/> Youth Commission
<input type="checkbox"/> Historical Commission	<input type="checkbox"/> Zoning Board of Appeals
<input type="checkbox"/> Housing Partnership	
<input type="checkbox"/> Human Rights Commission	

What skills and experience will you bring to this Committee assignment:

(attach additional sheet or resume if necessary)

RETIRED DAIRY FARMER

Are you currently serving or have you served on any City committee: _____ No Yes*

*(*If yes please state what committee)* _____

Required: Please read the following, by signing below you state that you understand and agree:

The filing of this form does not guarantee my appointment. An application is kept on file for two (2) years; after that I must file a new application. Being appointed to a committee, board, or commission means that I am considered a Municipal Employee under MGL Chapter 268A and thereby subject to Conflict of Interest Law MGL Chapter 268A, Financial Disclosure Law MGL Chapter 268B, as well as Open Meeting Law MGL Chapter 39: Section 23B. I understand that I will take the conflict of interest test AFTER being appointed and that I also must be sworn in by the City Clerk. I will contact the appointing authority with any questions about my service. **IMPORTANT: Once this form is submitted it becomes a public document, if there is information you do not want open to the public please do not include it on this form!**

SIGNATURE

John J. Bobala

DATE

20 APR 21

Please Return Form To: Mayor@northamptonma.gov or
 David J. Narkewicz, Mayor, 210 Main Street, Northampton, MA 01060



City of Northampton

Application for Appointment to Boards, Committees and Commissions

Name: Richard E. Jaescke
 Address: 774 Bridge Road
 Email: RCWlandscapes@AOL.COM
 Home Phone: 584 7898 Work: _____ Cell: 413 535 0775
 Occupation: Landscape Const/Farming Years lived in Northampton: 71
 Northampton Resident: Yes No

Please indicate the Committee(s) you have interest serving on: *(Appointment subject to vacancies)*

Agricultural Commission <input checked="" type="checkbox"/>	License Commission
Almoners, Board of	Municipal Affordable Housing Trust Fund Board of Trustees
Arts Council	Parks and Recreation Commission
Assessors, Board of	Planning Board
Central Business Architecture Committee	Public Shade Tree Commission
Community Preservation Committee	Public Works Commission
Conservation Commission	Redevelopment Authority
Council on Aging	Registrars, Board of
Disability Commission	Transportation & Parking Commission
Energy & Sustainability Commission	Trust Fund Committee
Health, Board of	Youth Commission
Historical Commission	Zoning Board of Appeals
Housing Partnership	
Human Rights Commission	

What skills and experience will you bring to this Committee assignment:

(attach additional sheet or resume if necessary)

Farmer in Northampton for 50 yrs

Are you currently serving or have you served on any City committee: _____ No Yes*
 (*If yes please state what committee) Ag - Commission

Required: Please read the following, by signing below you state that you understand and agree:
 The filing of this form does not guarantee my appointment. An application is kept on file for two (2) years; after that I must file a new application. Being appointed to a committee, board, or commission means that I am considered a Municipal Employee under MGL Chapter 268A and thereby subject to Conflict of Interest Law MGL Chapter 268A, Financial Disclosure Law MGL Chapter 268B, as well as Open Meeting Law MGL Chapter 39: Section 23B. I understand that I will take the conflict of interest test AFTER being appointed and that I also must be sworn in by the City Clerk. I will contact the appointing authority with any questions about my service. **IMPORTANT: Once this form is submitted it becomes a public document, if there is information you do not want open to the public please do not include it on this form!**

SIGNATURE Richard Jaescke DATE 4/20/2021

Please Return Form To: Mayor@northamptonma.gov or
 David J. Narkewicz, Mayor, 210 Main Street, Northampton, MA 01060



City of Northampton Application for Appointment to Boards, Committees and Commissions

Name: Robert Vollinger
 Address: 460 North Farms Rd. Florence MA.
 Email: RVollinger@gmail.com
 Home Phone: 413-268-3556 Work: _____ Cell: 413-626-4571
 Occupation: Farmer Years lived in Northampton: 30
 Northampton Resident: Yes No Farm in Northampton

Please indicate the Committee(s) you have interest serving on: *(Appointment subject to vacancies)*

Agricultural Commission <input checked="" type="checkbox"/>	License Commission
Almoners, Board of	Municipal Affordable Housing Trust Fund Board of Trustees
Arts Council	Parks and Recreation Commission
Assessors, Board of	Planning Board
Central Business Architecture Committee	Public Shade Tree Commission
Community Preservation Committee	Public Works Commission
Conservation Commission	Redevelopment Authority
Council on Aging	Registrars, Board of
Disability Commission	Transportation & Parking Commission
Energy & Sustainability Commission	Trust Fund Committee
Health, Board of	Youth Commission
Historical Commission	Zoning Board of Appeals
Housing Partnership	
Human Rights Commission	

What skills and experience will you bring to this Committee assignment:
(attach additional sheet or resume if necessary)

Farmer for over 30 years

Are you currently serving or have you served on any City committee: _____ No Yes*
*(*If yes please state what committee)* Ag.

Required: Please read the following, by signing below you state that you understand and agree:
 The filing of this form does not guarantee my appointment. An application is kept on file for two (2) years; after that I must file a new application. Being appointed to a committee, board, or commission means that I am considered a Municipal Employee under MGL Chapter 268A and thereby subject to Conflict of Interest Law MGL Chapter 268A, Financial Disclosure Law MGL Chapter 268B, as well as Open Meeting Law MGL Chapter 39: Section 23B. I understand that I will take the conflict of interest test AFTER being appointed and that I also must be sworn in by the City Clerk. I will contact the appointing authority with any questions about my service. **IMPORTANT: Once this form is submitted it becomes a public document, if there is information you do not want open to the public please do not include it on this form!**

SIGNATURE Robert Vollinger DATE 4/20/21

Please Return Form To: Mayor@northamptonma.gov or
 David J. Narkewicz, Mayor, 210 Main Street, Northampton, MA 01060



City of Northampton

Application for Appointment to Boards, Committees and Commissions

Name: Earle m. PARSONS
 Address: 137 mill valley Rd Hadley
 Email: ChipJDe@aol.com
 Home Phone: 584-8251 Work: _____ Cell: 413-219-7819
 Occupation: Farmer Years lived in Northampton: 14
 Northampton Resident: Yes No

Please indicate the Committee(s) you have interest serving on: *(Appointment subject to vacancies)*

<input checked="" type="checkbox"/> Agricultural Commission	License Commission
Almoners, Board of	Municipal Affordable Housing Trust Fund Board of Trustees
Arts Council	Parks and Recreation Commission
Assessors, Board of	Planning Board
Central Business Architecture Committee	Public Shade Tree Commission
Community Preservation Committee	Public Works Commission
Conservation Commission	Redevelopment Authority
Council on Aging	Registrars, Board of
Disability Commission	Transportation & Parking Commission
Energy & Sustainability Commission	Trust Fund Committee
Health, Board of	Youth Commission
Historical Commission	Zoning Board of Appeals
Housing Partnership	
Human Rights Commission	

What skills and experience will you bring to this Committee assignment:

(attach additional sheet or resume if necessary)

Have farmed with my family for many years
in the meadows. INVOLVED in ag organizations include
the Three County Fair

Are you currently serving or have you served on any City committee: _____ No _____ Yes*

*(*If yes please state what committee)* Ag Commission

Required: Please read the following, by signing below you state that you understand and agree:

The filing of this form does not guarantee my appointment. An application is kept on file for two (2) years; after that I must file a new application. Being appointed to a committee, board, or commission means that I am considered a Municipal Employee under MGL Chapter 268A and thereby subject to Conflict of Interest Law MGL Chapter 268A, Financial Disclosure Law MGL Chapter 268B, as well as Open Meeting Law MGL Chapter 39: Section 23B. I understand that I will take the conflict of interest test AFTER being appointed and that I also must be sworn in by the City Clerk. I will contact the appointing authority with any questions about my service. **IMPORTANT: Once this form is submitted it becomes a public document, if there is information you do not want open to the public please do not include it on this form!**

SIGNATURE Earle m. Par DATE 4/20/21

Please Return Form To: Mayor@northamptonma.gov or
 David J. Narkewicz, Mayor, 210 Main Street, Northampton, MA 01060



Online Form Submittal: Application for Appointment to Boards, Committees and Commissions

noreply@civicplus.com <noreply@civicplus.com>

Mon, May 3, 2021 at 10:24 AM

To: mayor@northamptonma.gov

Application for Appointment to Boards, Committees and Commissions

City of Northampton Application for Appointment to Boards, Committees, and Commissions

Please return the completed form to: Mayor@northamptonma.gov or David J. Narkewicz, Mayor 210 Main Street, Northampton, MA 01060

First Name	Joseph
Last Name	Blumenthal
Title, if applicable	<i>Field not completed.</i>
Address1	39 Chapel St.
Address2	<i>Field not completed.</i>
City	Northampton
State	MA
Zip	01060
Home Phone	413-586-0492
Work Phone	<i>Field not completed.</i>
Cell Phone	413-210-1654
Occupation & Place of Employment	retired
Email	<i>Field not completed.</i>
Are you a Northampton resident?	Yes
Years Lived in Northampton	47
Age	70 plus

Sex	<i>Field not completed.</i>
Racial / Ethnic Background	<i>Field not completed.</i>
Boards and Committees	Central Business Architecture Committee
Please list "other" board or committee of interest	<i>Field not completed.</i>
What skills and experience will you bring to this committee assignment?	long experience on the board and as owner of commercial real estate
Are you currently serving or have you served on any city committee?	Yes
Please list other city committees you have served on	CBAC

Required: Please read the following, by signing below you state that you understand and agree.

The filing of this form does not guarantee my appointment. An application is kept on file for two (2) years; after that I must file a new application. Being appointed to a committee, board, or commission means that I am considered a Municipal Employee under MGL Chapter 268A and thereby subject to Conflict of Interest Law MGL Chapter 268A, Financial Disclosure Law MGL Chapter 268B, as well as Open Meeting Law MGL Chapter 39: Section 23B. I understand that I will take the conflict of interest test after being appointed and that I also must be sworn in by the City Clerk. I will contact the appointing authority with any questions about my service. Important: Once this form is submitted it becomes a public document, if there is information you do not want open to the public please do not include it on this form.

Signature	Joseph Blumenthal
Date	5/3/2021

Email not displaying correctly? [View it in your browser.](#)



Online Form Submittal: Application for Appointment to Boards, Committees and Commissions

noreply@civicplus.com <noreply@civicplus.com>

Mon, May 3, 2021 at 4:27 PM

To: mayor@northamptonma.gov

Application for Appointment to Boards, Committees and Commissions

City of Northampton Application for Appointment to Boards, Committees, and Commissions

Please return the completed form to: Mayor@northamptonma.gov or David J. Narkewicz, Mayor 210 Main Street, Northampton, MA 01060

First Name	Susan
Last Name	Lofthouse
Title, if applicable	<i>Field not completed.</i>
Address1	15 Stoddard St.
Address2	<i>Field not completed.</i>
City	Northampton
State	MA
Zip	01060
Home Phone	<i>Field not completed.</i>
Work Phone	413-258-8645
Cell Phone	413-588-4083
Occupation & Place of Employment	New England Public Media Mid-Level Giving Manager
Email	slofthouse1@verizon.net
Are you a Northampton resident?	Yes
Years Lived in Northampton	32
Age	50 - 59

Sex	<i>Field not completed.</i>
Racial / Ethnic Background	white
Boards and Committees	Public Shade Tree Commission
Please list "other" board or committee of interest	<i>Field not completed.</i>
What skills and experience will you bring to this committee assignment?	Background in organizing, education, committee work, administration and communications. Founding member Tree Northampton. Experience attending meetings of UFC before and during service. Extensive volunteer participation in tree program.
Are you currently serving or have you served on any city committee?	Yes
Please list other city committees you have served on	Northampton

Required: Please read the following, by signing below you state that you understand and agree.

The filing of this form does not guarantee my appointment. An application is kept on file for two (2) years; after that I must file a new application. Being appointed to a committee, board, or commission means that I am considered a Municipal Employee under MGL Chapter 268A and thereby subject to Conflict of Interest Law MGL Chapter 268A, Financial Disclosure Law MGL Chapter 268B, as well as Open Meeting Law MGL Chapter 39: Section 23B. I understand that I will take the conflict of interest test after being appointed and that I also must be sworn in by the City Clerk. I will contact the appointing authority with any questions about my service. Important: Once this form is submitted it becomes a public document, if there is information you do not want open to the public please do not include it on this form.

Signature	Susan Lofthouse
Date	5/3/2021

[Quoted text hidden]



Online Form Submittal: Application for Appointment to Boards, Committees and Commissions

noreply@civicplus.com <noreply@civicplus.com>

Sun, Apr 25, 2021 at 6:36 PM

To: mayor@northamptonma.gov

Application for Appointment to Boards, Committees and Commissions

City of Northampton Application for Appointment to Boards, Committees, and Commissions

Please return the completed form to: Mayor@northamptonma.gov or David J. Narkewicz, Mayor 210 Main Street, Northampton, MA 01060

First Name	Robert
Last Name	Dionne
Title, if applicable	<i>Field not completed.</i>
Address1	87 Vernon Street
Address2	<i>Field not completed.</i>
City	NORTHAMPTON
State	MA
Zip	01060
Home Phone	14135844115
Work Phone	<i>Field not completed.</i>
Cell Phone	4133363404
Occupation & Place of Employment	Retired
Email	Parda@comcast.net
Are you a Northampton resident?	Yes
Years Lived in Northampton	50+
Age	70 plus

Sex	Male
Racial / Ethnic Background	Caucasian
Boards and Committees	Council on Aging
Please list "other" board or committee of interest	non at present
What skills and experience will you bring to this committee assignment?	Currently vice chair council on aging
Are you currently serving or have you served on any city committee?	No, Yes
Please list other city committees you have served on	Non at present

Required: Please read the following, by signing below you state that you understand and agree.

The filing of this form does not guarantee my appointment. An application is kept on file for two (2) years; after that I must file a new application. Being appointed to a committee, board, or commission means that I am considered a Municipal Employee under MGL Chapter 268A and thereby subject to Conflict of Interest Law MGL Chapter 268A, Financial Disclosure Law MGL Chapter 268B, as well as Open Meeting Law MGL Chapter 39: Section 23B. I understand that I will take the conflict of interest test after being appointed and that I also must be sworn in by the City Clerk. I will contact the appointing authority with any questions about my service. Important: Once this form is submitted it becomes a public document, if there is information you do not want open to the public please do not include it on this form.

Signature	Robert R. Dionne
Date	4/24/2021

[Quoted text hidden]



Online Form Submittal: Application for Appointment to Boards, Committees and Commissions

1 message

noreply@civicplus.com <noreply@civicplus.com>
To: mayor@northamptonma.gov

Fri, Apr 23, 2021 at 4:50 PM

Application for Appointment to Boards, Committees and Commissions

City of Northampton Application for Appointment to Boards, Committees, and Commissions

Please return the completed form to: Mayor@northamptonma.gov or David J. Narkewicz, Mayor 210 Main Street, Northampton, MA 01060

First Name	Jeanne Henry
Last Name	Hoose
Title, if applicable	<i>Field not completed.</i>
Address1	36 South Park Terrace
Address2	<i>Field not completed.</i>
City	Northampton
State	MA
Zip	01060
Home Phone	4136956438
Work Phone	<i>Field not completed.</i>
Cell Phone	<i>Field not completed.</i>
Occupation & Place of Employment	<i>Field not completed.</i>
Email	jeannehoose@gmail.com
Are you a Northampton resident?	Yes
Years Lived in Northampton	28
Age	60 - 69

Sex	Female
Racial / Ethnic Background	<i>Field not completed.</i>
Boards and Committees	Council on Aging
Please list "other" board or committee of interest	<i>Field not completed.</i>
What skills and experience will you bring to this committee assignment?	Past experience on council, serving as volunteer for senior center
Are you currently serving or have you served on any city committee?	No
Please list other city committees you have served on	Police building and skatepark

Required: Please read the following, by signing below you state that you understand and agree.

The filing of this form does not guarantee my appointment. An application is kept on file for two (2) years; after that I must file a new application. Being appointed to a committee, board, or commission means that I am considered a Municipal Employee under MGL Chapter 268A and thereby subject to Conflict of Interest Law MGL Chapter 268A, Financial Disclosure Law MGL Chapter 268B, as well as Open Meeting Law MGL Chapter 39: Section 23B. I understand that I will take the conflict of interest test after being appointed and that I also must be sworn in by the City Clerk. I will contact the appointing authority with any questions about my service. Important: Once this form is submitted it becomes a public document, if there is information you do not want open to the public please do not include it on this form.

Signature	Jeanne Henry Hoose
Date	4/23/2021

Email not displaying correctly? [View it in your browser.](#)



Online Form Submittal: Application for Appointment to Boards, Committees and Commissions

1 message

noreply@civicplus.com <noreply@civicplus.com>
To: mayor@northamptonma.gov

Fri, Apr 16, 2021 at 9:08 AM

Application for Appointment to Boards, Committees and Commissions

City of Northampton Application for Appointment to Boards, Committees, and Commissions

Please return the completed form to: Mayor@northamptonma.gov or David J. Narkewicz, Mayor 210 Main Street, Northampton, MA 01060

First Name	Dylan
Last Name	Gaffney
Title, if applicable	<i>Field not completed.</i>
Address1	23 Marshall St.
Address2	<i>Field not completed.</i>
City	Northampton
State	MA
Zip	01060
Home Phone	<i>Field not completed.</i>
Work Phone	<i>Field not completed.</i>
Cell Phone	4133205823
Occupation & Place of Employment	Forbes Library
Email	Dgaffney@forbeslibrary.org
Are you a Northampton resident?	Yes
Years Lived in Northampton	51
Age	50 - 59

Sex	Male
Racial / Ethnic Background	<i>Field not completed.</i>
Boards and Committees	Historical Commission
Please list "other" board or committee of interest	<i>Field not completed.</i>
What skills and experience will you bring to this committee assignment?	Years of experience on this board and historical knowledge about the city and its houses.
Are you currently serving or have you served on any city committee?	Yes
Please list other city committees you have served on	Historical Commission, Charter Review Committee
<p>Required: Please read the following, by signing below you state that you understand and agree.</p> <p><i>The filing of this form does not guarantee my appointment. An application is kept on file for two (2) years; after that I must file a new application. Being appointed to a committee, board, or commission means that I am considered a Municipal Employee under MGL Chapter 268A and thereby subject to Conflict of Interest Law MGL Chapter 268A, Financial Disclosure Law MGL Chapter 268B, as well as Open Meeting Law MGL Chapter 39: Section 23B. I understand that I will take the conflict of interest test after being appointed and that I also must be sworn in by the City Clerk. I will contact the appointing authority with any questions about my service. Important: Once this form is submitted it becomes a public document, if there is information you do not want open to the public please do not include it on this form.</i></p>	
Signature	Dylan Gaffney
Date	4/16/2021

Email not displaying correctly? [View it in your browser.](#)



Online Form Submittal: Application for Appointment to Boards, Committees and Commissions

2 messages

noreply@civicplus.com <noreply@civicplus.com>
To: mayor@northamptonma.gov

Sun, Apr 25, 2021 at 6:03 PM

Application for Appointment to Boards, Committees and Commissions

City of Northampton Application for Appointment to Boards, Committees, and Commissions

Please return the completed form to: Mayor@northamptonma.gov or David J. Narkewicz, Mayor 210 Main Street, Northampton, MA 01060

First Name	Barbara
Last Name	Blumenthal
Title, if applicable	<i>Field not completed.</i>
Address1	39 chapel street
Address2	<i>Field not completed.</i>
City	Northampton
State	Massachusetts
Zip	01060
Home Phone	4135860492
Work Phone	<i>Field not completed.</i>
Cell Phone	4132705464
Occupation & Place of Employment	<i>Field not completed.</i>
Email	bblument@smith.edu
Are you a Northampton resident?	Yes
Years Lived in Northampton	50
Age	60 - 69

Sex	Female
Racial / Ethnic Background	<i>Field not completed.</i>
Boards and Committees	Historical Commission
Please list "other" board or committee of interest	<i>Field not completed.</i>
What skills and experience will you bring to this committee assignment?	Knowledge of local history and experience while serving on NHC and as volunteer and docent at Historic Northampton. I'm requesting reappointment to NHC.
Are you currently serving or have you served on any city committee?	Yes
Please list other city committees you have served on	<i>Field not completed.</i>

Required: Please read the following, by signing below you state that you understand and agree.

The filing of this form does not guarantee my appointment. An application is kept on file for two (2) years; after that I must file a new application. Being appointed to a committee, board, or commission means that I am considered a Municipal Employee under MGL Chapter 268A and thereby subject to Conflict of Interest Law MGL Chapter 268A, Financial Disclosure Law MGL Chapter 268B, as well as Open Meeting Law MGL Chapter 39: Section 23B. I understand that I will take the conflict of interest test after being appointed and that I also must be sworn in by the City Clerk. I will contact the appointing authority with any questions about my service. Important: Once this form is submitted it becomes a public document, if there is information you do not want open to the public please do not include it on this form.

Signature	Barbara Blumenthal
Date	4/25/2021

Email not displaying correctly? [View it in your browser.](#)

noreply@civicplus.com <noreply@civicplus.com>
To: mayor@northamptonma.gov

Sun, Apr 25, 2021 at 6:36 PM

Application for Appointment to Boards, Committees and Commissions

City of Northampton Application for Appointment to Boards, Committees, and Commissions



Online Form Submittal: Application for Appointment to Boards, Committees and Commissions

1 message

noreply@civicplus.com <noreply@civicplus.com>
To: mayor@northamptonma.gov

Mon, May 3, 2021 at 12:28 PM

Application for Appointment to Boards, Committees and Commissions

City of Northampton Application for Appointment to Boards, Committees, and Commissions

Please return the completed form to: Mayor@northamptonma.gov or David J. Narkewicz, Mayor 210 Main Street, Northampton, MA 01060

First Name	Julio
Last Name	Alves
Title, if applicable	<i>Field not completed.</i>
Address1	35 Fort Hill Terrace
Address2	<i>Field not completed.</i>
City	Northampton
State	MA
Zip	01060
Home Phone	<i>Field not completed.</i>
Work Phone	413-585-3033
Cell Phone	413-824-8559
Occupation & Place of Employment	Director, Smith College
Email	jalves750@gmail.com
Are you a Northampton resident?	Yes
Years Lived in Northampton	11
Age	<i>Field not completed.</i>

Sex	<i>Field not completed.</i>
Racial / Ethnic Background	<i>Field not completed.</i>
Boards and Committees	Housing Partnership
Please list "other" board or committee of interest	<i>Field not completed.</i>
What skills and experience will you bring to this committee assignment?	I have been on the Housing Partnership for three years.
Are you currently serving or have you served on any city committee?	Yes
Please list other city committees you have served on	Housing Partnership
<p>Required: Please read the following, by signing below you state that you understand and agree.</p> <p><i>The filing of this form does not guarantee my appointment. An application is kept on file for two (2) years; after that I must file a new application. Being appointed to a committee, board, or commission means that I am considered a Municipal Employee under MGL Chapter 268A and thereby subject to Conflict of Interest Law MGL Chapter 268A, Financial Disclosure Law MGL Chapter 268B, as well as Open Meeting Law MGL Chapter 39: Section 23B. I understand that I will take the conflict of interest test after being appointed and that I also must be sworn in by the City Clerk. I will contact the appointing authority with any questions about my service. Important: Once this form is submitted it becomes a public document, if there is information you do not want open to the public please do not include it on this form.</i></p>	
Signature	Julio Alves
Date	5/3/2021

Email not displaying correctly? [View it in your browser.](#)



Online Form Submittal: Application for Appointment to Boards, Committees and Commissions

noreply@civicplus.com <noreply@civicplus.com>

Mon, May 3, 2021 at 12:39 PM

To: mayor@northamptonma.gov

Application for Appointment to Boards, Committees and Commissions

City of Northampton Application for Appointment to Boards, Committees, and Commissions

Please return the completed form to: Mayor@northamptonma.gov or David J. Narkewicz, Mayor 210 Main Street, Northampton, MA 01060

First Name	James
Last Name	Reis
Title, if applicable	<i>Field not completed.</i>
Address1	108 Coles Meadow Rd.
Address2	<i>Field not completed.</i>
City	Northampton
State	Massachusetts
Zip	01060
Home Phone	413-586-0567
Work Phone	<i>Field not completed.</i>
Cell Phone	413-588-2535
Occupation & Place of Employment	Retired from Way Finders
Email	reis13@comcast.net
Are you a Northampton resident?	Yes
Years Lived in Northampton	42 yrs.
Age	70 plus

Sex	Male
Racial / Ethnic Background	White
Boards and Committees	Housing Partnership
Please list "other" board or committee of interest	<i>Field not completed.</i>
What skills and experience will you bring to this committee assignment?	I retired from Way Finders after 15 yrs as the Associate Ex. Dir., and before that worked at the Franklin/Hampshire Community Mental Health Center in Northampton for 20 yrs. So I have housing development, homelessness, mental health, and community agency experience in Northampton.
Are you currently serving or have you served on any city committee?	Yes
Please list other city committees you have served on	Housing Partnership
<p>Required: Please read the following, by signing below you state that you understand and agree.</p> <p><i>The filing of this form does not guarantee my appointment. An application is kept on file for two (2) years; after that I must file a new application. Being appointed to a committee, board, or commission means that I am considered a Municipal Employee under MGL Chapter 268A and thereby subject to Conflict of Interest Law MGL Chapter 268A, Financial Disclosure Law MGL Chapter 268B, as well as Open Meeting Law MGL Chapter 39: Section 23B. I understand that I will take the conflict of interest test after being appointed and that I also must be sworn in by the City Clerk. I will contact the appointing authority with any questions about my service. Important: Once this form is submitted it becomes a public document, if there is information you do not want open to the public please do not include it on this form.</i></p>	
Signature	James Reis
Date	5/3/2021

[Quoted text hidden]



Online Form Submittal: Application for Appointment to Boards, Committees and Commissions

noreply@civicplus.com <noreply@civicplus.com>

Mon, May 3, 2021 at 1:44 PM

To: mayor@northamptonma.gov

Application for Appointment to Boards, Committees and Commissions

City of Northampton Application for Appointment to Boards, Committees, and Commissions

Please return the completed form to: Mayor@northamptonma.gov or David J. Narkewicz, Mayor 210 Main Street, Northampton, MA 01060

First Name	Julia
Last Name	Chevan
Title, if applicable	<i>Field not completed.</i>
Address1	8 Cosmian Avenue
Address2	<i>Field not completed.</i>
City	Florence
State	MA
Zip	01062
Home Phone	4136877141
Work Phone	4137483590
Cell Phone	4136877141
Occupation & Place of Employment	Professor and Chair, Department of Physical Therapy, Springfield College, Springfield MA
Email	jchevan@comcast.net
Are you a Northampton resident?	Yes
Years Lived in Northampton	31
Age	50 - 59

Sex	Female
Racial / Ethnic Background	<i>Field not completed.</i>
Boards and Committees	Parks and Recreation Commission
Please list "other" board or committee of interest	<i>Field not completed.</i>
What skills and experience will you bring to this committee assignment?	Careful and critical thinking. Knowledge of budgeting process and principles
Are you currently serving or have you served on any city committee?	Yes
Please list other city committees you have served on	Parks and Recreation, Community Preservation Committee

Required: Please read the following, by signing below you state that you understand and agree.

The filing of this form does not guarantee my appointment. An application is kept on file for two (2) years; after that I must file a new application. Being appointed to a committee, board, or commission means that I am considered a Municipal Employee under MGL Chapter 268A and thereby subject to Conflict of Interest Law MGL Chapter 268A, Financial Disclosure Law MGL Chapter 268B, as well as Open Meeting Law MGL Chapter 39: Section 23B. I understand that I will take the conflict of interest test after being appointed and that I also must be sworn in by the City Clerk. I will contact the appointing authority with any questions about my service. Important: Once this form is submitted it becomes a public document, if there is information you do not want open to the public please do not include it on this form.

Signature	Julia Chevan
Date	5/3/2021

[Quoted text hidden]



Online Form Submittal: Application for Appointment to Boards, Committees and Commissions

noreply@civicplus.com <noreply@civicplus.com>

Mon, May 3, 2021 at 2:44 PM

To: mayor@northamptonma.gov

Application for Appointment to Boards, Committees and Commissions

City of Northampton Application for Appointment to Boards, Committees, and Commissions

Please return the completed form to: Mayor@northamptonma.gov or David J. Narkewicz, Mayor 210 Main Street, Northampton, MA 01060

First Name	George
Last Name	Kohout
Title, if applicable	<i>Field not completed.</i>
Address1	234 State St
Address2	<i>Field not completed.</i>
City	N'ton
State	MA
Zip	01060
Home Phone	<i>Field not completed.</i>
Work Phone	<i>Field not completed.</i>
Cell Phone	413 320 2226
Occupation & Place of Employment	retired
Email	geokohout@gmail.com
Are you a Northampton resident?	Yes
Years Lived in Northampton	35
Age	60 - 69

Sex	Male
Racial / Ethnic Background	White
Boards and Committees	Planning Board
Please list "other" board or committee of interest	<i>Field not completed.</i>
What skills and experience will you bring to this committee assignment?	I Served on the Planning Board from 2000 - 2009, took a few years off and was reappointed to the Board in July 2018. This application is for a reappointment to the Board
Are you currently serving or have you served on any city committee?	Yes
Please list other city committees you have served on	Community Preservation Committee, Capital Improvements Program

Required: Please read the following, by signing below you state that you understand and agree.

The filing of this form does not guarantee my appointment. An application is kept on file for two (2) years; after that I must file a new application. Being appointed to a committee, board, or commission means that I am considered a Municipal Employee under MGL Chapter 268A and thereby subject to Conflict of Interest Law MGL Chapter 268A, Financial Disclosure Law MGL Chapter 268B, as well as Open Meeting Law MGL Chapter 39: Section 23B. I understand that I will take the conflict of interest test after being appointed and that I also must be sworn in by the City Clerk. I will contact the appointing authority with any questions about my service. Important: Once this form is submitted it becomes a public document, if there is information you do not want open to the public please do not include it on this form.

Signature	George Kohout
Date	5/3/2021

[Quoted text hidden]



Online Form Submittal: Application for Appointment to Boards, Committees and Commissions

noreply@civicplus.com <noreply@civicplus.com>

Tue, May 4, 2021 at 9:24 AM

To: mayor@northamptonma.gov

Application for Appointment to Boards, Committees and Commissions

City of Northampton Application for Appointment to Boards, Committees, and Commissions

Please return the completed form to: Mayor@northamptonma.gov or David J. Narkewicz, Mayor 210 Main Street, Northampton, MA 01060

First Name	Maureen
Last Name	Scanlon
Title, if applicable	Field not completed.
Address1	197 NONOTUCK ST
Address2	Field not completed.
City	FLORENCE
State	MA
Zip	01062-1907
Home Phone	4135888071
Work Phone	Field not completed.
Cell Phone	Field not completed.
Occupation & Place of Employment	Self employed graphic designer: Sole proprietor, Murre Creative, 221 Pine Street, Florence
Email	maureen@maureenscanlon.com
Are you a Northampton resident?	Yes
Years Lived in Northampton	40
Age	60 - 69

Sex	Female
Racial / Ethnic Background	White
Boards and Committees	Zoning Board of Appeals
Please list "other" board or committee of interest	<i>Field not completed.</i>
What skills and experience will you bring to this committee assignment?	Served one term on ZBA to date. Previous relevant experience: Served on the Design Review Committee for the city of Winooski, VT before moving to Northampton in 1981
Are you currently serving or have you served on any city committee?	Yes
Please list other city committees you have served on	ZBA as noted above

Required: Please read the following, by signing below you state that you understand and agree.

The filing of this form does not guarantee my appointment. An application is kept on file for two (2) years; after that I must file a new application. Being appointed to a committee, board, or commission means that I am considered a Municipal Employee under MGL Chapter 268A and thereby subject to Conflict of Interest Law MGL Chapter 268A, Financial Disclosure Law MGL Chapter 268B, as well as Open Meeting Law MGL Chapter 39: Section 23B. I understand that I will take the conflict of interest test after being appointed and that I also must be sworn in by the City Clerk. I will contact the appointing authority with any questions about my service. Important: Once this form is submitted it becomes a public document, if there is information you do not want open to the public please do not include it on this form.

Signature	Maureen Scanlon
Date	5/4/2021

Email not displaying correctly? [View it in your browser.](#)

City of Northampton
MASSACHUSETTS

In City Council

May 6, 2021

Upon recommendation of the Mayor

21.264 An Order for FY2021 Budget Transfers

Ordered, that

The following budgetary transfers be made:

Department		Description	Org	Object	Transfer From:	Transfer To:
DPW Forestry, Parks and Cemeteries	PS	Permanent Salaries	14921	511000	\$ (40,000)	
DPW Forestry, Parks and Cemeteries	OOM	Grounds Equipment	14923	571001		\$ 40,000
Fire Rescue	PS	Permanent Salaries	12201	511000	\$ (46,000)	
Fire Rescue	OM	Equipment Replacement	12202	587000		\$ 46,000
Employee Benefits	PS	Medical Insurance	19141	519400	\$(132,456)	
Other Employee Benefits	PS	Medicare	19191	517001	\$ (26,588)	
Unemployment	PS	Unemployment Compensation	19131	519300	\$ (23,668)	
Health	PS	Salaries Permanent	15111	511000	\$ (29,744)	
Assessors	PS	Permanent Salaries	11411	511000	\$ (8,004)	
Mayor	PS	Overtime	11211	513000		\$ 1,475
Mayor	PS	Permanent Salaries	11211	511000		\$ 14,000
Planning and Sustainability	PS	Overtime	11751	513000		\$ 7,995
Building Inspections	PS	Overtime	12411	513000		\$ 13,750
Building Inspections	PS	Salaries Tech/Prof	12411	512000		\$ 16,997
DPW Administration	PS	Permanent Salaries	14211	511000		\$ 3,608
DPW Snow and Ice	PS	Overtime	14231	513000		\$ 45,651
DPW Snow and Ice	OM	Vehicular Supplies	14232	548000		\$ 37,553
DPW Snow and Ice	OM	Snow Removal Supplies	14232	553020		\$ 79,431
Assessors	PS	Permanent Salaries	11411	511000	\$ (26,500)	
Assessors	OM	Property Revaluation Services	11412	530014		\$ 26,500
Total Budgetary Transfers:					\$(332,960)	\$ 332,960

City of Northampton

MASSACHUSETTS

In City Council, May 6, 2021

Upon the recommendation of Mayor David J. Narkewicz

**O-21.265 AN ORDER AUTHORIZING ACQUISITION AND
ESTABLISHMENT OF A MUNICIPAL LIGHT PLANT**

WHEREAS, the Mayor and City Council approved a two-phase market study and comprehensive feasibility study of municipal broadband as part of the FY2020-FY2024 Capital Improvement Program; and

WHEREAS, the City of Northampton awarded a contract for the aforementioned two-phase study to Design Nine, Inc. which has completed a market study, the overwhelmingly positive results of which dictate moving forward with the comprehensive feasibility study; and

WHEREAS, if based on the results of both studies the City of Northampton decides to implement municipal broadband, the city would be required to establish a Municipal Light Plant in accordance with M.G.L. c. 164, § 35; and

WHEREAS, establishment of a Municipal Light Plan under section 35 first requires two separate approval votes of the City Council by a two-thirds majority in two separate fiscal years; and

WHEREAS, the City Council approved the establishment of a Municipal Light Plan in fiscal year 2020 on June 18, 2020; and

WHEREAS, in the interest of not unnecessarily delaying a future potential municipal broadband project, it would be prudent to complete the second required approval vote in fiscal year 2021 ending June 30, 2021.

NOW, THEREFORE, be it ordered, the City Council authorizes in accordance with the provisions of Chapter 164 of the General Laws and in accordance with the rules, regulations and orders of the Department of Public Utilities and the Department of Telecommunications & Cable, a municipal lighting plant for all purposes allowable under the laws of the Commonwealth, and more particularly for the establishment a municipal broadband system for the City of Northampton. The Mayor is hereby authorized to execute any documents necessary to effectuate this Order.

City of Northampton

MASSACHUSETTS

In City Council, April 15, 2021

Upon the recommendation of Mayor David J. Narkewicz, Conservation Commission and Planning & Sustainability

21.244 An Order to Acquire and Amend Easements at the Mill River Greenway-Smith College

Ordered, that

WHEREAS, The ***Open Space and Recreation Plan: 2018-2025*** recommends expanding public access along the Mill River as part of the ***Mill River Greenway*** and the ***Climate Resilience and Regeneration Plan (2021)*** recommends moving to renewable energy and electrification of thermal loads;

WHEREAS, The Trustees of the Smith College granted the City an ***Open Space Restriction and Public Right of Way Easement*** recorded at Hampshire Registry of Deeds at Book 5900, Page 26 (3/14/2000) and Book 5898, Page 39 (3/9/2000);

WHEREAS, The City of Northampton would like to revise this restriction to be a formal conservation restriction in accordance with MGL Chapter 184, Section 31;

WHEREAS, Smith College would reserve the right to use area within 200 feet of the gravel road shown on a plan entitled "*Boundary Survey of Land of the Commonwealth of Massachusetts, formerly the Northampton State Hospital, Northampton, Massachusetts*" dated December 17, 1996 and recorded at Hampshire Registry of Deeds (Plan Book 183, Page 3, Sheet 3) for any parking uses. This area is currently allowed for parking for recreation uses and expanding to non-recreation uses will have no adverse impact on the conservation values;

WHEREAS, Smith College would reserve the right for underground piping and heat exchange for ground sourced heat pumps on the premises so that, other than during construction, reconstruction, and repair activities, the facilities will not be visible above grade. This use is consistent with the City's *Climate Resilience and Regeneration Plan* and will have no adverse impact on conservation values;

WHEREAS, Smith College is prepared to simultaneously expand the existing easement "to allow the public to pass and repass on foot trails for the purpose of fishing, hiking, winter sports..." to include all trails within 100 feet of the Mill River, on the northeasterly side of the Mill River, northerly and westerly of the Smith College crew house, and westerly of College Lane on the Smith College campus;

WHEREAS, The amendments of the open space restriction requires approval of the Massachusetts General Court under Article 97 of the Amendments to the State Constitution.

Ordered, that

The Mayor and the Conservation Commission is authorized to amend the existing ***Open Space Restriction and Public Right of Way Easement*** to expand the uses of existing parking areas, allow underground piping for ground source heat pumps, and accept the new expanded easement;

Further, the City requests and petitions that our legislative delegation file legislation substantially as follows:

An Act authorizing the City of Northampton to amend a certain conservation easement.

Be it enacted by the Senate and House of Representatives in General Court assembled, and by the authority of the same as follows:

SECTION 1. Notwithstanding any general or special law to the contrary, the city of Northampton, acting by and through its mayor and conservation commission, may amend the Open Space Restriction and Public Right of Way Easement recorded at Hampshire Registry of Deeds at Book 5900, Page 26 and Book 5898, Page 39 to allow any parking within 200 feet of the gravel road shown on a plan entitled "Boundary Survey of Land of the Commonwealth of Massachusetts, formerly the Northampton State Hospital, Northampton, Massachusetts" dated December 17, 1996 and recorded at Hampshire Registry of Deeds at Plan Book 183, Page 3, Sheet 3 and allow underground piping and heat exchange for ground source heat pumps and to record the new restriction as a conservation restriction under the authority of MGL Chapter 184, Section 31.

SECTION 2. As a condition and in consideration for the amendment to the easement as provided in section 1 of this act, and at the same time as such release, the city of Northampton, acting by and through its conservation commission, shall accept an expanded public right-of-way easement to allow the public to pass and repass on foot trails for the purpose of fishing, hiking, winter sports on all trails within 100 feet of the Mill River on the northerly side of the river, northerly and westerly of the Smith College crew house, and westerly of College Lane on the Smith College campus, Northampton.

City of Northampton
MASSACHUSETTS

In City Council, April 15, 2021

Upon the recommendation of the Community Preservation Committee

21.248 An Order to Appropriate CPA Funds for Historic Northampton Collections Storage

Ordered, that

WHEREAS, Historic Northampton, Inc. submitted a Small Grants application for Community Preservation Act funding to purchase appropriate collections storage for its ephemera, photograph and research collections;

WHEREAS, the collections yield important information about Northampton's history, and are frequently accessed for research by community members, businesses, and nonprofits;

WHEREAS, improved collections storage was a critical recommendation of the Massachusetts State Historic Records Board, and will protect these resources for the future;

WHEREAS, on February 17, 2021 the Northampton Community Preservation Committee, voted unanimously to recommend that \$3,000 in Community Preservation Act funds be used to support this project.

NOW, THEREFORE BE IT ORDERED,

That \$3,000 be appropriated from Community Preservation Act funding to Historic Northampton, Inc. for purchase and installation of new collections storage. And, that the grantee meets the conditions approved by the Community Preservation Committee, the Mayor, and City Council.

Specifically, \$3,000 is appropriated from the CPA Historic Preservation Reserve (account #2344930-359932).

City of Northampton

MASSACHUSETTS

In City Council, April 15, 2021

Upon the recommendation of the Community Preservation Committee

21.249 An Order to Appropriate \$120,000 in CPA Funds Toward Habitat Housing on Burts Pit Road

Ordered, that

WHEREAS, Pioneer Valley Habitat for Humanity submitted an application for Community Preservation Act funding for creation of three energy efficient affordable homes on Burts Pit Road;

WHEREAS, Habitat for Humanity has an excellent record of creating housing throughout the Pioneer Valley and beyond;

WHEREAS, the project has wide community support, leverages funding from many other sources, and utilizes volunteer labor;

WHEREAS, the homes will be permanently restricted to individuals and families earning 60% of area median income or below;

WHEREAS, on April 7, 2021, the Northampton Community Preservation Committee voted unanimously to recommend that \$120,000 in Community Preservation Act funds be used to support this project.

NOW, THEREFORE BE IT ORDERED,

That \$120,000 be appropriated from Community Preservation Act funding to Pioneer Valley Habitat for Humanity for the Broughton's Meadow Small Home Project. And, that the grantee meets the conditions approved by the Community Preservation Committee, the Mayor, and City Council.

Specifically, \$39,525 is appropriated from the CPA Budgeted Reserve (account #2344930-359930, and is \$80,475 allocated from the CPA Affordable Housing Reserve (account #2344930-359933)

City of Northampton
MASSACHUSETTS

In City Council, April 15, 2021

Upon the recommendation of the Community Preservation Committee

21.250 An Order to Appropriate \$14,500 in CPA Funds to Lilly Library Stair Repair Project

Ordered, that

WHEREAS, Lilly Library. submitted a CPA application for Community Preservation Act funding to conduct critical structural repairs to the historic entrance to the Library;

WHEREAS, all work will be consistent with the Secretary of the Interior Standards for the Treatment of Historic Properties;

WHEREAS, Lilly Library is an institution that has been an essential component of the Florence community for over 130 years, and this project will maintain the historic nature while ensuring continued functionality of the building;

WHEREAS, on April 7, 2021 the Northampton Community Preservation Committee, voted unanimously to recommend that \$14,500 in Community Preservation Act funds be used to support this project.

NOW, THEREFORE BE IT ORDERED,

That \$14,500 be appropriated from Community Preservation Act funding to Lilly Library for the Stair Repair project. And, that the grantee meets the conditions approved by the Community Preservation Committee, the Mayor, and City Council. Specifically, \$14,500 is appropriated from the CPA Historic Preservation Reserve (account #2344930-359932).

City of Northampton
MASSACHUSETTS

In City Council, April 15, 2021

Upon the recommendation of the Community Preservation Committee
21.251 An Order to Appropriate \$70,000 in CPA Funds for Historic Preservation Plan

Ordered, that

WHEREAS, the Office of Planning and Sustainability submitted an application for Community Preservation Act funding for creation of a Historic Preservation Plan to identify historic and cultural resources, assess current status, recognize issues and opportunities to help ensure that those resources are protected;

WHEREAS, through a collaborative community process and analysis of resource data and community values, the Plan will develop a vision, goal, priorities, and toolbox for preservation of priority historic and cultural resources and will become a component of the City's Sustainable Northampton Comprehensive Plan;

WHEREAS, on April 7, 2021, the Northampton Community Preservation Committee, voted unanimously to recommend that \$70,000 in Community Preservation Act funds be used to support this project.

NOW, THEREFORE BE IT ORDERED,

That \$70,000 be appropriated from Community Preservation Act funding to the Historic Preservation Plan. And, that the grantee meets the conditions approved by the Community Preservation Committee, the Mayor, and City Council.

Specifically, \$5,891 is allocated from the CPA Historic Preservation Reserve (account #2344930-359932), and \$64,109 is allocated from the CPA Budgeted Reserve (account #2344930-359930).

City of Northampton
MASSACHUSETTS

In City Council, April 15, 2021

Upon the recommendation of the Community Preservation Committee
21.252 An Order to Appropriate \$21,250 for Damon House/Shepherd Barn Project

Ordered, that

WHEREAS, Historic Northampton, Inc. submitted a CPA application for Community Preservation Act funding for restoration of the Damon House roofline balustrade, and for a structural analysis of the Shepherd Barn;

WHEREAS, all work will be consistent with the Secretary of the Interior's Standards for the Treatment of Historic Properties;

WHEREAS, CPA funds will be used to help secure an important historic resource that is valued by the community and the region, on which the City holds a permanent preservation restriction, and will expand Historic Northampton's public programming opportunities;

WHEREAS, on April 7, 2021 the Northampton Community Preservation Committee, voted unanimously to recommend that \$21,250 in Community Preservation Act funds be used to support this project.

NOW, THEREFORE BE IT ORDERED,

That \$21,250 be appropriated from Community Preservation Act funding to Historic Northampton, Inc. for the Shepherd/Damon project. And, that the grantee meets the conditions approved by the Community Preservation Committee, the Mayor, and City Council.

Specifically, \$21,250 is appropriated from the CPA Historic Preservation Reserve (account #2344930-359932).

City of Northampton
MASSACHUSETTS

In City Council, April 15, 2021

Upon the recommendation of the Community Preservation Committee

21.253 An Order to Appropriate \$60,000 in CPA Funds for Mill River Greenway Beach Project

Ordered, that

WHEREAS, the Northampton Conservation Commission and Office of Planning & Sustainability submitted a CPA application to acquire a 3.3 acre parcel along the Mill River in Leeds abutting the existing Mill River Greenway which includes recreational opportunities for all seasons;

WHEREAS, subject to the City successfully negotiating a conservation restriction which contains an adequate private party maintenance agreement;

WHEREAS, the project meets the goals of the Sustainable Northampton Plan, Northampton Community Preservation Plan, and Open Space, Recreation and Multi-use Trail Plan to protect open space, and provide recreational opportunities;

WHEREAS, on April 7, 2021, the Northampton Community Preservation Committee voted unanimously to recommend that \$60,000 in Community Preservation Act funds be used to support this project.

NOW, THEREFORE BE IT ORDERED,

That \$60,000 be appropriated from Community Preservation Act funding to the Northampton Conservation Commission and Office of Planning and Sustainability for the Mill River Greenway Beach acquisition Project. And, that the grantee meets the conditions approved by the Community Preservation Committee, the Mayor, and City Council.

Specifically, \$60,000 is appropriated from the CPA Budgeted Reserve (account #2344930-359930).

City of Northampton
MASSACHUSETTS

In City Council, April 15, 2021

Upon the recommendation of the Community Preservation Committee
21.254 An Order to Appropriate \$50,000 in CPA Funds to the Affordable Housing Fund

Ordered, that

WHEREAS, the Office of Planning and Sustainability submitted an application for Community Preservation Act funding for the Affordable Housing Fund;

WHEREAS, the fund will be used for due diligence and soft costs for predevelopment work necessary for new affordable housing opportunities that the City creates, and for which no other funds are readily available, and will help to leverage future funding opportunities from other sources;

WHEREAS, this fund will result in new affordable housing opportunities in Northampton, meets the goals of the Housing Needs Assessment and Strategic Plan, and will help to address impediments to fair housing identified in the Fair Housing Assessment;

WHEREAS, on April 7, 2021, the Northampton Community Preservation Committee, voted unanimously to recommend that \$50,000 in Community Preservation Act funds be used to support this project.

NOW, THEREFORE BE IT ORDERED,

That \$50,000 be appropriated from Community Preservation Act funding to the Affordable Housing Fund. And, that the grantee meets the conditions approved by the Community Preservation Committee, the Mayor, and City Council.

Specifically, \$50,000 is allocated from the CPA Affordable Housing Reserve (account #2344930-359933)

City of Northampton

MASSACHUSETTS

In City Council, April 15, 2021

Upon the recommendation of Mayor David J. Narkewicz and Department of Planning and Sustainability

**21.255 AN ORDER AUTHORIZING ACQUISITION OF A PARCEL OF LAND
ON THE SOUTHEASTERLY SIDE OF BRIERWOOD DRIVE**

WHEREAS, the parcel subject to this Order is located on the southeasterly side of Brierwood Drive and is shown on a plan of land entitled "Plan of Lots in Northampton, Mass. Owned by Edbert Homes, Inc.," dated July 12, 1965, and recorded in Hampshire Registry of Deeds in Plan Book 67, Pages 94-95, ("the Plan") being the southernly one-third of lot 31-A on the Plan ("the Parcel"); and

WHEREAS, the Parcel excludes that portion of lot 31-A that is shown on the plan entitled "Plan of Lots in Northampton, Mass. Owned by Edbert Homes, Inc.," dated April 1964, and recorded in the Hampshire Registry of Deeds in Plan Book 65, Page 56A, also shown thereon as lot 31-A; and

WHEREAS, the Parcel abuts the property of the R.K. Finn Ryan Road Elementary School; and

WHEREAS, the owner of the Parcel, Edbert Homes, Inc., was involuntarily dissolved by order of the Secretary of the Commonwealth in 1979; and

WHEREAS, the Parcel is subject to an existing tax lien for unpaid taxes that exceed the value of the Parcel; and

WHEREAS, the Parcel contains the layout of a City sewer line; and

WHEREAS, the Parcel would enhance access to the abutting school property from the neighborhood shown on the Plan.

NOW, THEREFORE BE IT ORDERED,

The City Council hereby authorizes the acquisition by purchase, gift, eminent domain, or otherwise of the Parcel described above for access to and egress from the land of the R.K. Finn Ryan Road Elementary School.

As damages for the taking, the City Council hereby awards Three Thousand One Hundred Dollars (\$3,100.00) which shall be applied to the outstanding balance on taxes due and owing on the Parcel.

**Property Address:
Southeasterly Side of Brierwood Drive
Florence, MA**

ORDER OF TAKING

The undersigned, being the duly elected and sitting members of the City Council of the City of Northampton, in the Commonwealth of Massachusetts, acting under the authority of and in accordance with the provisions of General Laws of the Commonwealth, as from time to time amended, and more particularly Chapter 79, and pursuant to the Order of the Northampton City Council, a true copy of which is attached hereto as Exhibit A, does hereby take the parcel of land herein described in fee simple absolute for access to the R.K. Finn Ryan Road School.

The land taken herein is shown as Lot 31-A on a plan of land recorded in the Hampshire Registry of Deeds, Plan Book 67, Page 94, but specifically excepting and excluding the parcel of land shown as Lot 31-A on a plan recorded in Plan Book 65, Page 56A and also described in a deed recorded in Book 1486, Page 148.”

As pro tanto damages for the taking herein, the City of Northampton awards the sum of \$3,100.00, which shall be applied to reduce or release the tax lien encumbering such parcel.

For title see deed of Martin J. Beattie and Catherine C. Beattie to Edbert Homes, Inc., dated September 30, 1959, and recorded in the Hampshire Registry of Deeds Book 1312, Page 353.

[SIGNATURE PAGES FOLLOW]

IN WITNESS WHEREOF, We, the City Council of the City of Northampton, have executed this Order of Taking this _____ day of _____, 2021.

WITNESS TO ALL:

CITY COUNCIL, CITY OF NORTHAMPTON, MA

Gina-Louise Sciarra
AT-LARGE COUNCILOR

William H. Dwight
AT-LARGE COUNCILOR

Michael Quinlan, Jr.
WARD 1 COUNCILOR

Karen Foster
WARD 2 COUNCILOR

James Nash
WARD 3 COUNCILOR

John Thorpe
WARD 4 COUNCILOR

Alex Jarrett
WARD 5 COUNCILOR

Marianne L. LaBarge
WARD 6 COUNCILOR

Rachel Maiore
WARD 7 COUNCILOR

CERTIFICATE OF THE CLERK
CITY COUNCIL, CITY OF NORTHAMPTON, MA

I, Laura Krutzler, the Clerk of the City Council of the City of Northampton, MA, hereby certify that the attached Order of Taking of a certain parcel of land located in Northampton, Hampshire County, Massachusetts, was executed on _____, 2021, by Gina-Louise Sciarra, William H. Dwight, Michael Quinlan, Jr., Karen Foster, James Nash, John Thorpe, Alex Jarrett, Marianne L. LaBarge, and Rachel Maoire, who as of that day, were and are the duly elected members of the City Council of the City of Northampton, MA.

Signed this _____ day of _____, 2021.

Laura Krutzler
Clerk to City Council
City of Northampton, Massachusetts

EXHIBIT A
CITY COUNCIL ORDER

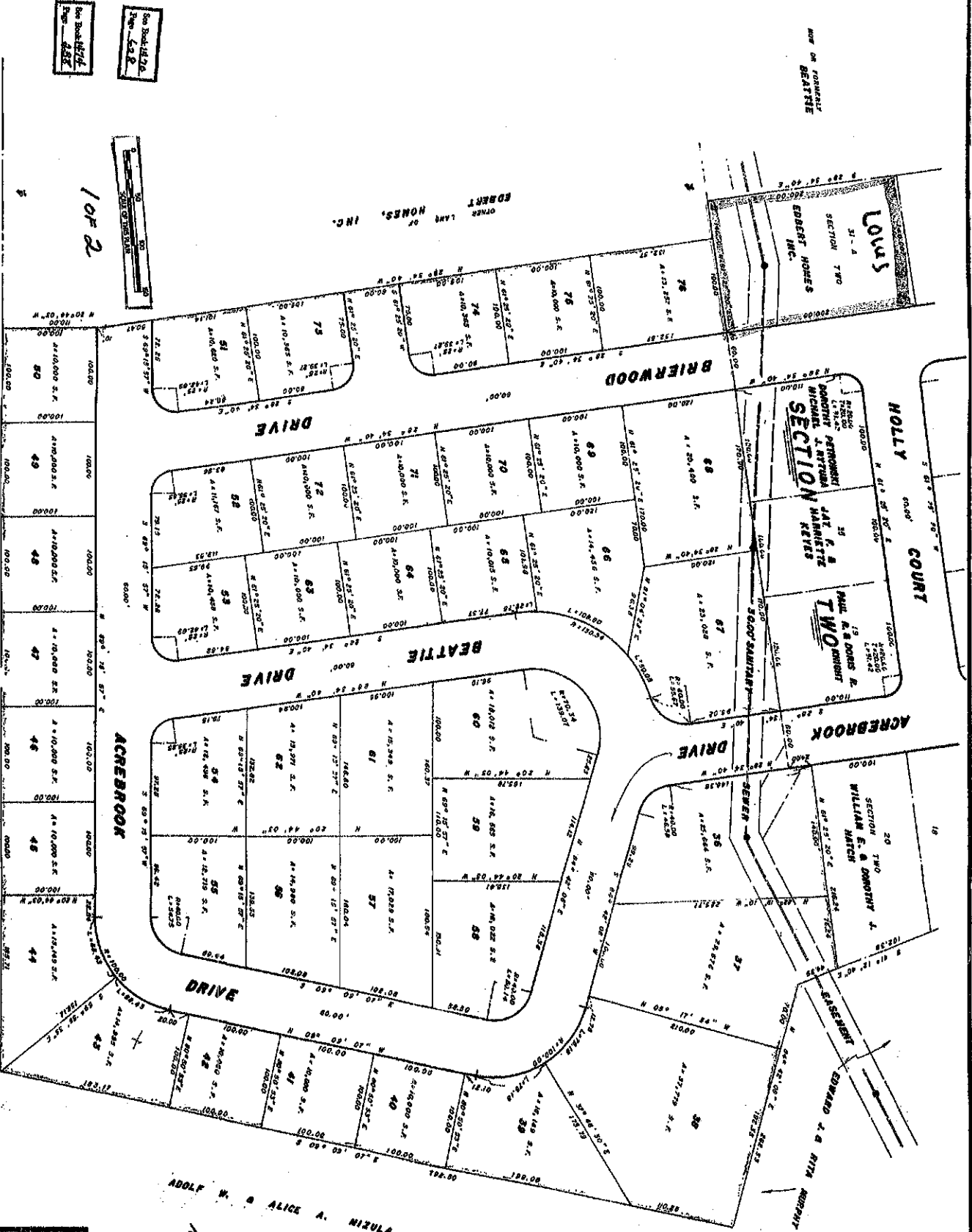

See Book 67 of
Plat 488

See Book 67 of
Plat 488

1 of 2

Robert Lamm
of
Robert Homes, Inc.

Holly Court

SECTION

ADOLF W. & ALICE A. MIZULA
368-154

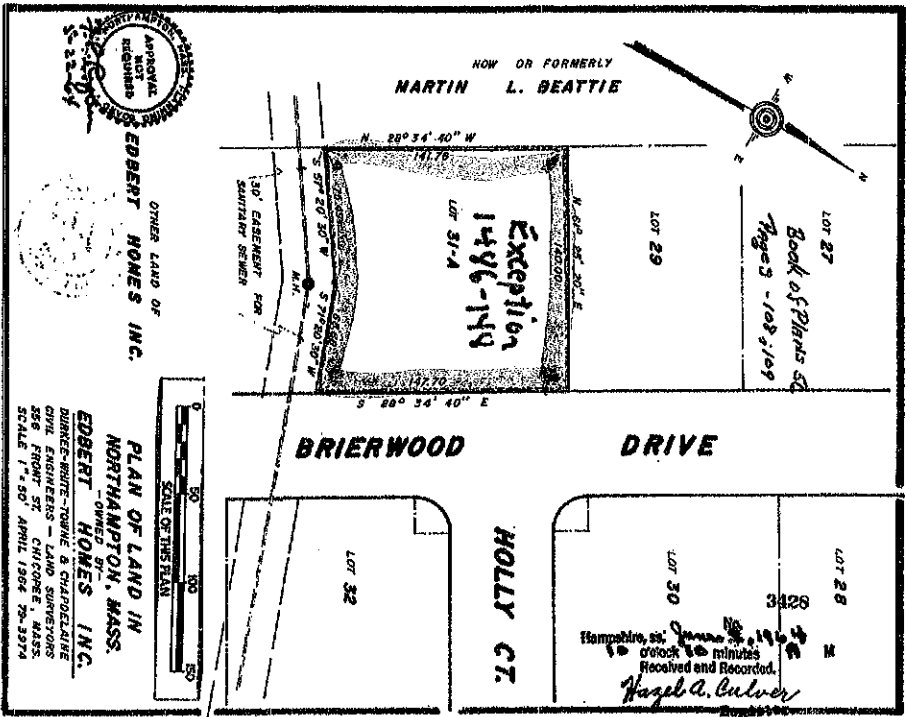

NOTICE OF NONEXERCISE
City of Northampton Right Refusal/Option
G.L. c. 61A

OWNER: Robert A. Borawski and Ann M. Borawski
17 Audubon Road, Northampton, MA 01060
Book 7156, Page 275

Premises: Parcel A, **Plan Book 248, Page 90**
2.93 Acres +/-, off Kennedy Road

The City of Northampton hereby affirms that it has elected not to exercise its right of refusal/option to purchase the above referenced parcel after receipt of Notice of Sale from the above referenced Owner, in compliance with G.L. c. 61A, and release its lien and option to purchase from the lien in **Book 2413, Page 775**.

City of Northampton

Witness

By: _____
David Narkewicz, Mayor

Approved:

Alan Seewald, City Solicitor

COMMONWEALTH OF MASSACHUSETTS

County of Hampshire

On this ____ day of _____, 2021, before me, the undersigned notary public, personally appeared David Narkewicz, and proved to me through satisfactory evidence of identification, which was personal knowledge, to be the person whose name is signed on the preceding or attached document, and acknowledged to me that he signed it voluntarily for its stated purpose as the mayor of The City of Northampton as the voluntary act of such entity.

Notary Public
My Commission Expires:

**CITY OF NORTHAMPTON
MASSACHUSETTS**

In the Year Two Thousand and Twenty-One

Upon the Recommendation of the Transportation and Parking Commission

**21.198
AN ORDINANCE**

**RELATIVE TO A STOP SIGN ON
SCANLON AVENUE**

An Ordinance of the City of Northampton, Massachusetts. Be it ordained by the City Council of the City of Northampton, in City Council assembled, as follows:

SECTION 1

That the § 312-113 of the Code of Ordinances be amended as follows:

§ 312-113 Schedule XII: Stop and Yield Intersections.

Location	Direction of Travel	At the Intersection of
<u>Scanlon Avenue</u>	<u>West</u>	<u>Florence Road</u>

**CITY OF NORTHAMPTON
MASSACHUSETTS**

In the Year Two Thousand and Twenty-One

Upon the Recommendation of the Transportation and Parking Commission

**21.199
AN ORDINANCE**

**RELATIVE TO STOP SIGNS ON
CROSS STREET**

An Ordinance of the City of Northampton, Massachusetts. Be it ordained by the City Council of the City of Northampton, in City Council assembled, as follows:

SECTION 1

That the § 312-113 of the Code of Ordinances be amended as follows:

§ 312-113 Schedule XII: Stop and Yield Intersections.

Location	Direction of Travel	At the Intersection of
<u>Cross Street</u>	<u>West</u>	<u>Florence Road</u>
<u>Cross Street</u>	<u>East</u>	<u>Bliss Street</u>

**CITY OF NORTHAMPTON
MASSACHUSETTS**

In the Year Two Thousand and Twenty-One

Upon the Recommendation of Mayor David J. Narkewicz and the Department of Public Works

**21.213
AN ORDINANCE**

**RELATIVE TO PARKING ON
PINE STREET**

An Ordinance of the City of Northampton, Massachusetts. Be it ordained by the City Council of the City of Northampton, in City Council assembled, as follows:

SECTION 1

That the § 312-102 of the Code of Ordinances be amended as follows:

§ 312-102 Schedule I: Parking Prohibited All Times.

Location	Side	From	To
Pine Street [Added 8-15-1985]	North-wes terly	Chestnut Street	Point 210 feet north- westerly from Chestnut Street South Main Street

**CITY OF NORTHAMPTON
MASSACHUSETTS**

In the Year Two Thousand and Twenty-One

Upon the Recommendation of Mayor David J. Narkewicz and the Department of Public Works

**21.214
AN ORDINANCE**

**RELATIVE TO STOP SIGNS ON
MAPLE STREET, MANN TERRACE, AND PINE STREET**

An Ordinance of the City of Northampton, Massachusetts. Be it ordained by the City Council of the City of Northampton, in City Council assembled, as follows:

SECTION 1

That the § 312-113 of the Code of Ordinances be amended as follows:

§ 312-113 Schedule XII: Stop and Yield Intersections.

A. Isolated stop signs. Stop intersections are established at the following locations:

Location	Direction of Travel	At the Intersection of
Pine Street	East	Maple Street
Pine Street	West	Maple Street
<u>Mann Terrace</u>	<u>North</u>	<u>Pine Street</u>

D. Multiway stop signs. Multiway stop intersections are established at the following locations:

Name of Street	Direction of Travel	Intersection
<u>Pine Street</u>	<u>East/West</u>	<u>Maple Street</u>
<u>Maple Street</u>	<u>North/South</u>	<u>Pine Street</u>

**CITY OF NORTHAMPTON
MASSACHUSETTS**

In the Year Two Thousand and Twenty-One

Upon the Recommendation of Mayor David J. Narkewicz and the Department of Public Works

**21.215
AN ORDINANCE**

**RELATIVE TO TURNING RESTRICTION ON
MANN TERRACE**

An Ordinance of the City of Northampton, Massachusetts. Be it ordained by the City Council of the City of Northampton, in City Council assembled, as follows:

SECTION 1

That the § 312-115 of the Code of Ordinances be amended as follows:

§ 312-115 Schedule XIV: Left Turns Prohibited.

Name of Street	Direction of Travel	Left Turn Prohibited Onto
<u>Mann Terrace</u>	<u>North</u>	<u>Pine Street</u>

**CITY OF NORTHAMPTON
MASSACHUSETTS**

In the Year Two Thousand and Twenty-One

Upon the Recommendation of Mayor David J. Narkewicz and the Department of Public Works

**21.216
AN ORDINANCE**

**RELATIVE TO ONE-WAY STREET ON
MANN TERRACE**

An Ordinance of the City of Northampton, Massachusetts. Be it ordained by the City Council of the City of Northampton, in City Council assembled, as follows:

SECTION 1

That the § 312-112 of the Code of Ordinances be amended as follows:

§ 312-112 Schedule XI: One-Way Streets.

Location	Direction	From	To
Mann Terrace	Northwesterly	A point 60 feet southeasterly of Pine Street	Pine Street